

UDC 629.463:629.4.023

**Andrii Sulym**<sup>1\*</sup>, **Oleksandr Safronov**<sup>2</sup>, **Andrii Strynzha**<sup>3</sup>, **Pavlo Khozia**<sup>4</sup>

<sup>1</sup>Deputy Director for Scientific Work, State Enterprise "Ukrainian Scientific Railway Car Building Research Institute", 33, I. Pryhodka Str., Kremenchuk, 39621, Ukraine. ORCID: <https://orcid.org/0000-0001-8144-8971>.

<sup>2</sup>Director, State Enterprise "Ukrainian Scientific Railway Car Building Research Institute", 33, I. Pryhodka Str., Kremenchuk, 39621, Ukraine. ORCID: <https://orcid.org/0000-0002-5865-7756>.

<sup>3</sup>Head of the Research Laboratory, Research Laboratory of Freight and Special Purpose Railway Vehicles, State Enterprise "Ukrainian Scientific Railway Car Building Research Institute", 33, I. Pryhodka Str., Kremenchuk, 39621, Ukraine.", ORCID: <https://orcid.org/0000-0003-3743-7006>.

<sup>4</sup>Head of the Research Laboratory, Research Laboratory of Experimental Studies of Railway Technics, State Enterprise "Ukrainian Scientific Railway Car Building Research Institute", 33, I. Pryhodka Str., Kremenchuk, 39621, Ukraine. ORCID: <https://orcid.org/0000-0001-8948-6032>.

\* **Corresponding author:** sulim1.ua@gmail.com

## Ways of improving of freight car design

*The article presents the dynamics of freight cars production by domestic enterprises by years. The necessity of renewal of the domestic operating fleet of freight cars. The following main vectors of design improvement have been identified based on the results of putting new and modified freight car models into production: use of high-strength steels in load-bearing structural elements and innovative components; improving existing and creating fundamentally new bearing structures; the most efficient use of space; development of freight cars with an axle load of 25 tonnes; creation of multifunctional structures; increasing the structural strength of long-base flat cars; application of the latest assembly and welding technologies. The following main vectors for improving the design of cars have been identified based on the results of a analysis of scientific and applied research, in addition to the above: the use of new materials; development of six-axle articulated wagons with an axle load of 23.5 tonnes and 25 tonnes; development of railcars using new generation bogies and components; achieving a uniform load on the supporting structure; design of flat cars for transporting containers in two tiers; development of new cars for intermodal, interoperable and combined transport.*

**Keywords:** freight car, design, fleet, rolling stock, improvement.

**Introduction and problem statement.** In recent years, the dynamics of freight car production has been on a downward trend [1]. The dynamics of freight car production in recent years is shown in Fig. 1.

Over the past few years, the number of freight rolling stock manufacturers has declined significantly. The armed aggression of the Russian Federation was the main reason for the destruction of enterprises, insufficient supply of metal and castings, the need to import certain components of freight cars, and the destruction of logistics routes that had been developed over the years. The main reasons for the decline in freight car production in recent years are the following: the purchase of expired freight cars from the Customs Union; lack of a comprehensive programme to renew the domestic freight car fleet, decrease in demand for rail freight transportation due to various reasons (competition from other modes of transport, economic downturn, COVID-19, armed aggression of the Russian Federation, etc.), lack of incentives to purchase innovative freight rolling stock [1-3].

All of this demonstrates the need and urgency to support the freight car building industry at the state level to prevent its complete destruction. Therefore, in the context of significant depreciation of the freight rolling stock fleet, a catastrophic drop in freight car production, and martial law in the country, it is of paramount importance that the government supports the freight car industry by adopting appropriate legislative initiatives. One of such effective measures and support mechanisms from the central executive body that ensures and implements state policy in the field of transport may be to stimulate the purchase of modern innovative freight cars with improved technical characteristics.

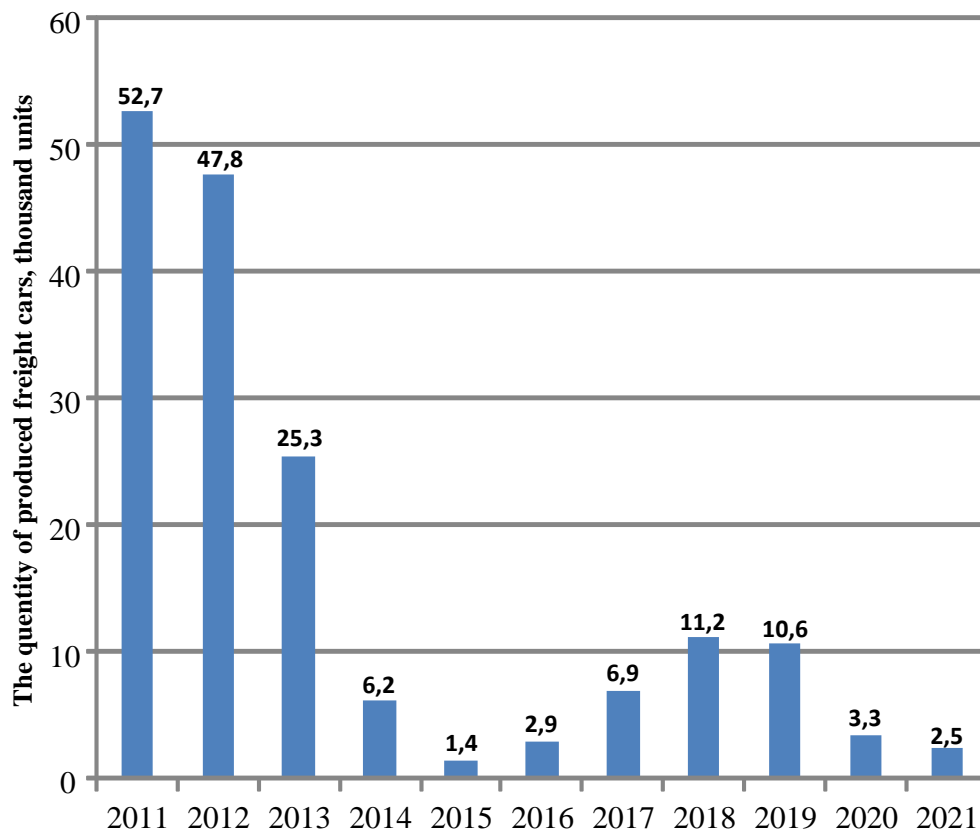

*Fig. 1. Freight car production dynamics by years [1]*

**Analysis of recent research.** The first steps in this direction were taken in 2015-2021. Thus, in 2015, the Technical Council of Ukrzaliznytsia adopted technical requirements for innovative freight rolling stock [4]. In July 2020, the Resolution of the Cabinet of Ministers of Ukraine No. 1147 dated 30.12.2015 "On the Prohibition of Importation of Goods Originating from the Russian Federation into the Customs Territory of Ukraine" [5] was amended to prohibit the importation into the customs territory of Ukraine of railway cars that are or have been in use among the railway administrations of the Russian Federation since 20.02.2014. In December 2021, the Ministry of Infrastructure approved the concept of renewing the freight car fleet by registering this order with the Ministry of Justice of Ukraine [6]. However, the proposed concept from the Ministry of Infrastructure has a number of problematic issues in its implementation, which are discussed in detail in the publication [1]. The main problematic issues are the uncertainty of the sources of funding for this renewal concept and the lack of incentives for the purchase of innovative freight cars from the state.

At the same time, taken into account the challenges of today, the issue of further development of the freight car fleet in the country remains open and relevant. One of the components of the effective implementation of innovative freight rolling stock is the compliance of its technical characteristics with modern requirements. Therefore, updating the technical requirements for the development of innovative

freight rolling stock is an important and urgent task. A prerequisite for updating and formulating technical requirements should be a review and analysis of ways to improve the design of freight cars during 2015-2022. This paper proposes to focus on this issue in detail.

**The goal** is to identify the main areas for improving the design of freight cars by reviewing and analysing technical documentation for freight cars, research and development works, research and development studies, and recent titles of protection.

**Research material and results.** It is proposed to determine the main directions for improving the design of freight cars by reviewing and analysing the technical documentation for freight cars, research papers, numerous existing studies of a scientific and applied nature, and titles of protection published and approved recently [7-75].

The technical documentation and research works on new models of freight cars produced by domestic enterprises [7-12], which were put into production during the recent period, were reviewed and analysed firstly. The exterior of some cars with the improved innovative design that have recently been put into production is shown in Figs. 2-5.



**Fig. 2. Freight cars of models 15-776Э, 19-7126, 19-7053-04, 13-7132, 13-7138, 11-7139, 15-7140, 33-7141, 19-7154 produced by PJSC “KRCBW”**

Based on the results of the analysis of technical documentation for new and modified models of freight cars that have been put into production by domestic enterprises recently, as well as research and development work, the following main vectors of design improvement have been identified:

- the use of high-strength steels in structural load-bearing elements and innovative component parts, which allows for a longer life cycle and increased overhaul interval of railcars;
- strengthening, improving of existing cars and creating fundamentally new types of freight car load-bearing structures;
- maximum efficient use of dimensions, including inter-car space;
- development of a freight cars range with an axle load of 25 tonnes;
- development of multifunctional freight car designs capable of transporting a wide range of goods;
- increasing the structural strength of long-base flat cars;

– application of the latest assembly and welding technologies.



**Fig. 3. Freight cars of models 31-4154, 19-4146-01, 19-4152, 12-4106-01, 13-4147, 33-4099 produced by LLC “Dniprovagonmash”**

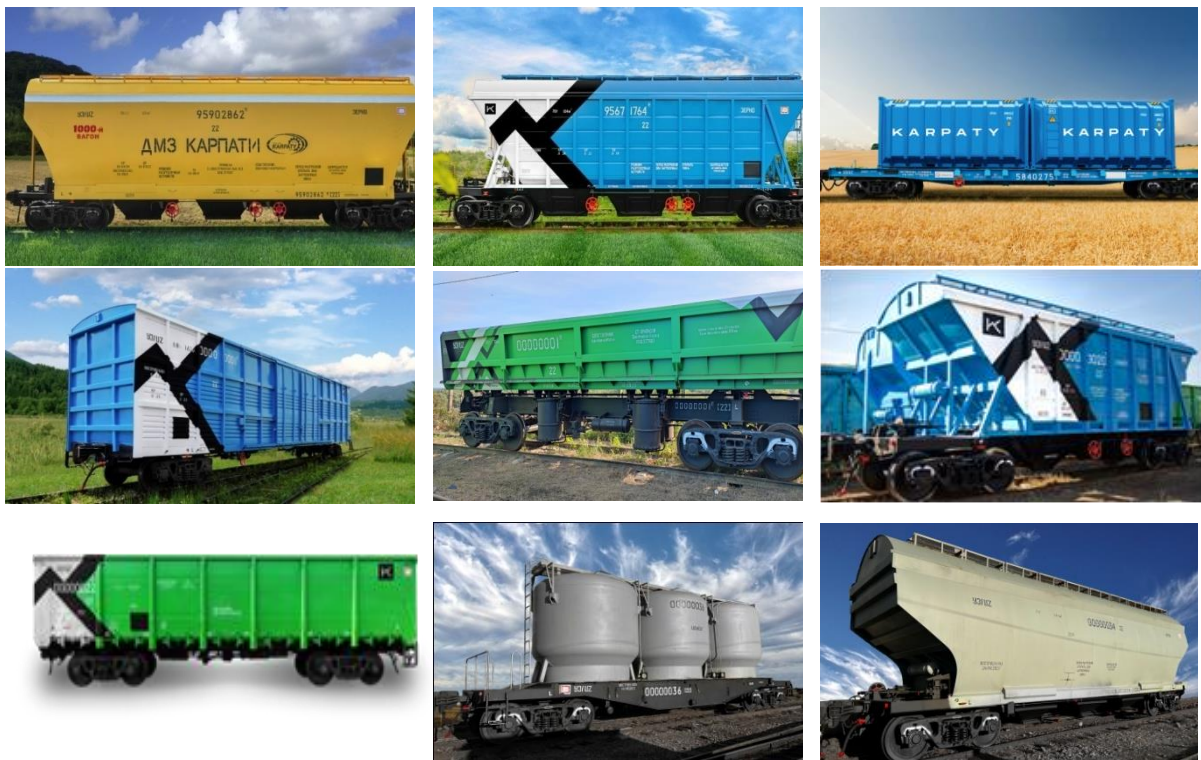

**Fig. 4. Freight cars of models 19-6869, 19-9951, 13-9589, 11-9983, 32-8525, 19-8530, 12-8520, 19-1883, 17-1890 produced by LLC “RMF “Karpaty”**



**Fig. 5. Freight cars of models 13-6961, 19-6938 produced by “Panyutyn Carriage Repair Plant” branch of JSC “Ukrzaliznytsia” and model 12-6708-02 produced by LLC “Zhmerynka Railway Repair Plant “Express”**

It should also be noted that domestic railcar manufacturers are currently actively developing the production of freight cars for use on a 1435 mm gauge. Thus, PJSC "KRCBW" received certificates for specialised articulated flat cars of the Sggrss 80 and Sggmrss 90' types for compliance with European standards. The general view of the articulated flat cars manufactured by PJSC "KRCBW" is shown in Fig. 6.



**Fig. 6. General view of articulated flat cars type Sggrss 80 (a) and Sggmrss 90' (b) produced by PJSC “KRCBW”**

Numerous scientific and applied studies have been reviewed and analysed [13-28]. In their publications, based on the studies of freight car structures loaded, the authors propose to improve both their single components and the metal structures of freight cars as a whole, in order to increase their strength, service life and maintenance intervals. In these studies, it was proposed to improve the technical characteristics of freight cars by using higher steel classes and new materials with improved mechanical properties, a different design of components and parts, and achieving uniform load on the bearing structure. To increase the strength of the load-bearing structure of freight cars, the use of fillers in their load-bearing structures, in particular in the girders, was proposed in the publications [29-31]. Some of the promising load-bearing metal structures of freight cars proposed in these studies are shown in Fig. 7.

Studies [32-37] are devoted to the modernization and other design of coupling devices and mechanisms of undercar braking equipment of freight cars. Also, a sufficient number of works [38-47] are devoted to the improvement of freight car bogies and their components. In the vast majority of these studies, the possibility of using welded bogies as part of freight cars is considered. A lot of work has also been done to study the functioning of improved or new components of the freight car bogie, such as side frames, wheel sets, spring suspension elements, etc. Some of the improved designs of freight car side frames and bogies are shown in Fig. 8.

Particular attention should be paid to the works of domestic and foreign researchers [48-55], which propose to create multifunctional freight cars, platform cars for the transportation of containers in two tiers, as well as to develop new types of cars for intermodal, interoperable, combined transportation.

Multifunctional freight cars are capable of transporting a wide range of goods, their design is versatile and allows them to be used as a boxcar, gondola car, platform car, etc. The introduction of multifunctional railcars will significantly reduce the empty mileage rate during operation and increase the technical and economic effect of their use. The introduction of platform wagons for transporting containers in two tiers, as well as new types of wagons for intermodal, interoperable and combined transport, will generally increase the efficiency of freight transport by improving logistics and the speed of cargo delivery.

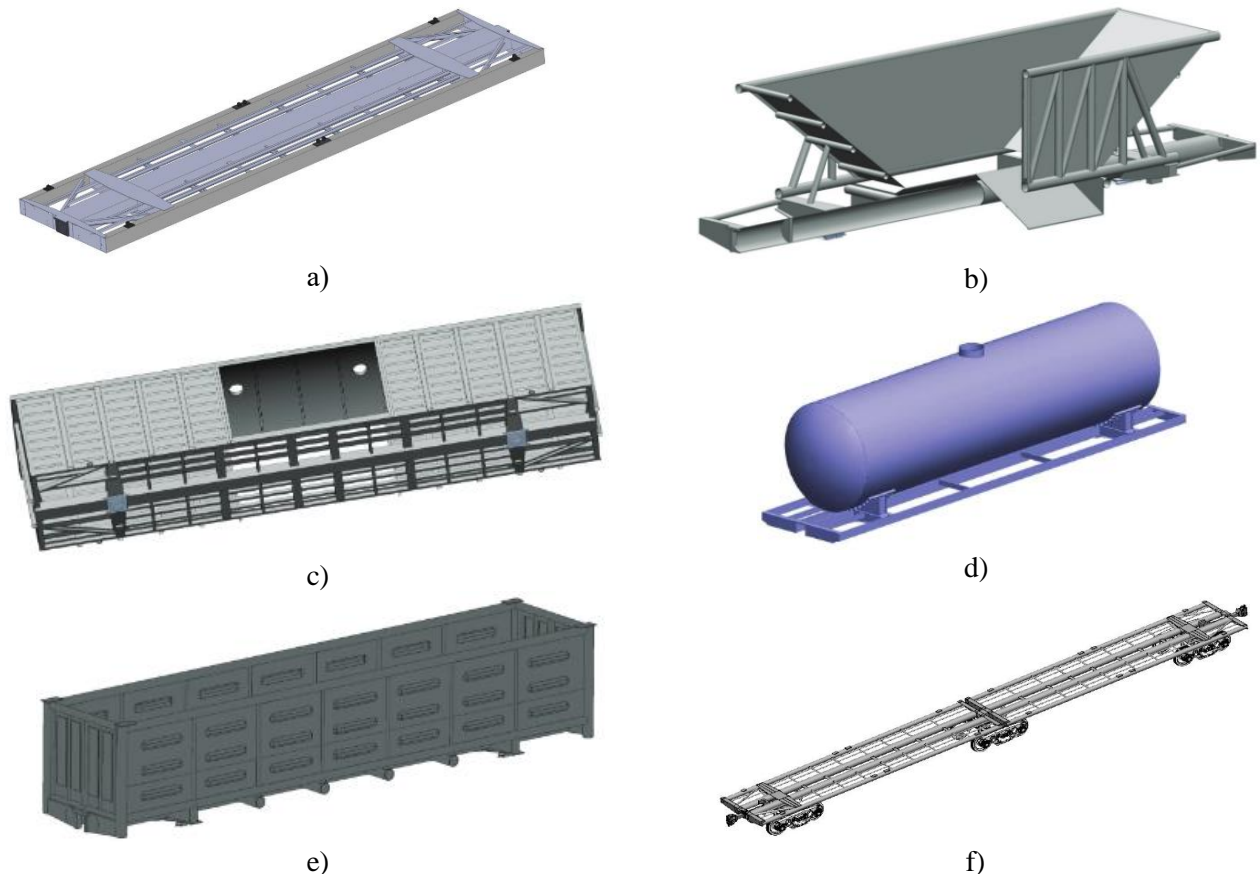

**Fig. 7. Spatial models of load-bearing structures: a) fitting flat car[29]; b) hopper car [14]; c) boxcar [31]; d) tank car [30]; e) open-top car [18]; f) articulated flat car[13, 30]**

Papers [56-60] are devoted to research in the direction of increasing the axle load on the railway track, which will increase the carrying capacity of freight cars, increase the volume of cargo transportation, and reduce the number of operating freight cars. Fig. 9 shows the models of universal gondola cars of Ukrainian manufacturers with a load capacity of 25 tf/axle, which have passed the production procedure and can be mass-produced. The manufacturer of gondola car model 12-9791 on bogies model 18-9817 is “Diesel Plan” OJSC (now Aurum Group); model 12-7039 on bogies model 18-7033 is PJSC “KRCBW”; model 12-1905 on bogies model 18-1711 is PJSC “Azovmash”.

Publications [61-63] are aimed at conducting and highlighting the results of scientific and experimental studies of newly developed models of freight cars with the purpose to putting them into production. Some of the existing studies [64, 65] focus on the development of modern requirements for the technical characteristics of freight cars in order to improve their design. Publications [66-75] are aimed at refining the calculations, mathematical and computer models in the design of freight cars.

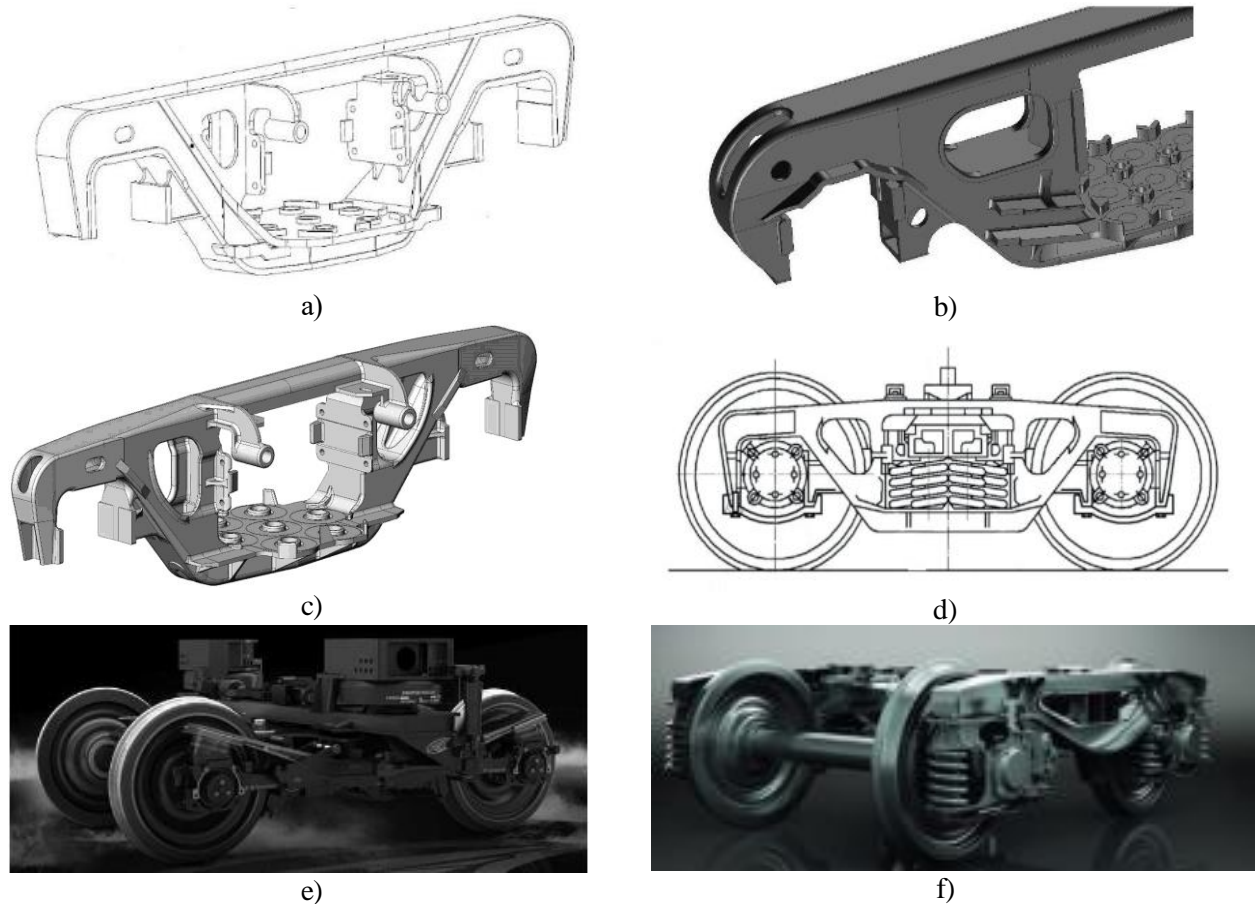

**Fig. 8. Running parts models of freight cars: a) side frame of welded structure [38]; b) comprehensively modernized cast side frame [44]; c) cast side frame of an improved design [41]; d) cast bogie of an improved design with a box string [40]; e) new bogie of welded structure [46]; f) welded bogie of improved design [47]**

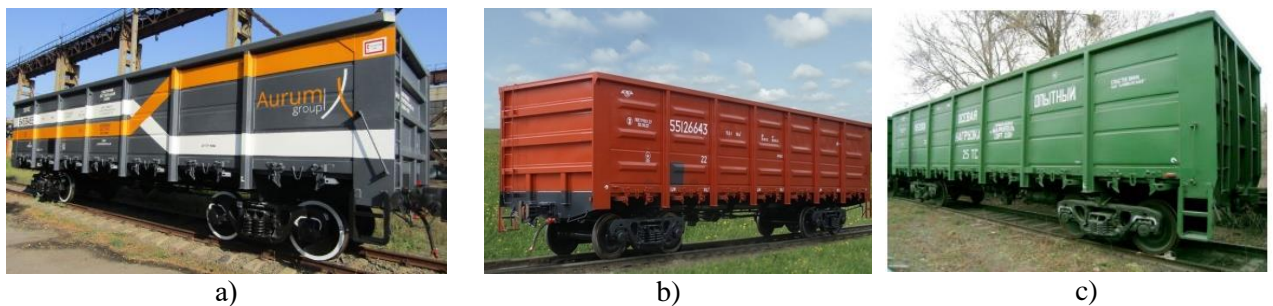

**Fig. 9. Freight cars of models with axle load 25 tonnes: a) model 12-9791 on bogies model 18-9817; b) model 12-7039 on bogies model 18-7033; c) model 12-1905 on bogies model 18-1711**

Thus, based on the results of the review and analysis of scientific and applied research by domestic and foreign scientists, in addition to the above-mentioned results of the technical documentation analysis for newly developed freight car models and research works, the following main vectors of design improvement were identified:

- development of a wide range of six-axle articulated cars with axle loads of 23.5 tonnes and 25 tonnes;
- development of cars using welded bogies and new generation components for them;

- achieving a equal load on the load-bearing structure;
- design of flat cars for transporting containers in two tiers;
- development of new types of wagons for intermodal, interoperable, combined transport.

An analysis of domestic titles of protection relating to freight cars published recently allowed us to identify the following main vectors of improvement:

- strengthening, improving existing and creating fundamentally new types of freight car bodies and load-bearing structures;
- modernisation of existing freight car bogies and their components;
- creation of six-axle articulated cars;
- development of a wide range of freight cars with improved technical characteristics, including new types of cars for intermodal, interoperable and combined transport;
- application of the latest assembly and welding technologies.

Based on the results of the review and analysis of technical documentation for freight cars, research and development works, scientific and applied research, and titles of protection, it was found that the teams of scientific and educational institutions have recently made a significant contribution to the development of domestic freight car building: State enterprise «Ukrainian Scientific Railway Car Building Research Institute», State University of Infrastructure and Technologies, Dnipropetrovsk National University of Railway Transport named after Academician V. Lazaryan (now Ukrainian State University of Science and Technology), Institute of Electric Welding named after E.O. Paton, Eastern Ukrainian National University named after V. Dahl, LLC “Head Specialized Designing Car Building Bureau named after V. M. Bubnov”, Ukrainian University Railway Transport, “Scientific Research Design And Technological Institute of Railway Transport” branch of JSC “Ukrzaliznytsia”, enterprises and companies: JSC “Ukrzaliznytsia”, LLC “RMF “Karpaty”, PJSC “INTERPIPE NTRP”, PJSC “KRCBW”, JSC “KSP”, LLC “Dniprovagonmash”, CLG “Popasnian Car Repair Plant”, LLC “AZOVVAGON”, LLC “BTsP “Tribo”, LLC “ZCRP “Express”, LLC “POLTAVVAGON”, LLC “Poltava Locomotive Repair Plant”, LLC “UKRNAFTOZAPCHASTYNA”, “Panyutyn Carriage Repair Plant” branch of JSC “Ukrzaliznytsia” and others.

At the same time, it should be noted the significant personal contribution to the development of new and improvement of existing designs of freight cars and their components of the following Ukrainian scientists, engineers and researchers: Babaev A.M., Bagrov O.M., Bubnov V.M., Vatuli G.L., Vodiannikova Yu.Ya., Golubenko O.L., Gorbunova M.I., Hrygoroshenka M.V., Dolinskoho S. V., Donchenko A.V., Dyomina Y.V., Ilchyshyn V.V., Kalashnyka V.O., Kara S.V., Kebal Y.V., Kelrich M.B., Kostrytsya S.A., Kravchenko K.O., Lobanov L.M., Lovska A.O., Mankevich M.B., Martynov I.E., Mozheyko E.R., Muradyan L.A., Myamlin S.V., Myamlin S.S., Neduzha L.O., Nozhenko O.S., Panchenko S.V., Petrenka V.O., Prokopenka P.M., Ravlyuka V.G., Rybina A. V., Reidemeister O.G., Sapronova S.Yu., Trufanova A.V., Fedosov-Nikonov D.V., Fomin V.V., Fomin O.V., Chernyak G.Yu., Shaposhnyk V. Yu., Shvets A.O., Shikunov O.A.

Among foreign scientists in the field of creating multifunctional railcars and new types of railcars for intermodal, interoperable and combined transport, the following works should be highlighted Płaczek M., Wróbel A., Buchacz A., Gerlici J., Lack T., Dižo J., Harušinec J., Blatnický M., Šťastniak P., Moravčík M., Smetanka L., Chuan-jin, O., Bing-tao., Wiesław K., Tadeusz N., Michał S., Kurčík P., Pavlík A., Lewandowski K., Krason W., Niezgodna T., Stoilov V., Simić G., Purgić S., Milković D., Fabian P., Masek J., Marton P., Lee H.-A., Jung S.-B., Jang H.-H., Shin D.-H., Lee J. U., Kim K. W., Park G.-J., Nandan S., Trivedi R., Kant S., Ahmad J., Maniraj M.

**Conclusions.** The following main ways of improving the design of freight cars have been identified based on the results of review and analysis of technical documentation for freight cars, research works, research and development works, and titles of protection published recently:

- use of new materials with enhanced mechanical properties and high-strength steel classes in the manufacture of freight cars and its individual components, which will help to improve the strength and reliability of the structure, increase the overhaul intervals and service life of cars;

- improvement of existing and creation of fundamentally new types of load-bearing structures, in the construction of which innovative rational technical solutions are used, which will allow modifying outdated structures and improving the technical and economic performance of freight cars;
- the most efficient use of dimensions, including the inter-car space, which will increase the carrying capacity and volume of the car body;
- development of a range of freight cars with an axle load of 25 tonnes, which will increase the carrying capacity and body volume of the freight car and reduce the tare ratio;
- creation of six-axle articulated freight cars of a wide range with an axle load of 23.5 and 25 tonnes, which will increase the carrying capacity and body volume;
- development of freight cars with new-generation bogies and components, as well as other removable components and mechanisms of improved design, which will increase safety, improve the dynamics and smoothness of freight car movement, and extend the time between overhauls;
- strengthening the bearing structures of freight cars and individual component parts to improve their reliability, achieve uniform loading of the bearing structure elements and increase service life by reducing damage from loads during operation;
- creation of multifunctional freight car designs capable of transporting a wide range of goods, which will significantly reduce the empty mileage ratio and increase the efficiency of rail freight transportation;
- increasing the structural strength of long-base platform cars, which will improve the reliability and service life of such cars and reduce their damage from loads during operation;
- development of a platform car design for the transport of large containers in two tiers, which will increase the speed and efficiency of container transport by rail;
- development of new types of freight cars for intermodal, interoperable, combined transport, which will increase the speed of cargo delivery in general and the efficiency of rail transport in particular;
- application of the latest assembly and welding technologies, which will reduce labour intensity, the cost of manufacturing railcars and the environmental impact of railcar manufacturing companies.

## REFERENCES

1. Sulym, A. O., Safronov, O. M., & Strynzha, A.M. (2022) Obgruntuvannya neobkhidnosti derzhavnogo protektsionizmu u vantazhnomu vahonobuduvanni Ukrainy. [Justification of the need for state protectionism in the freight car building industry in Ukraine.] *Zbirnyk naukovykh prats «Reikovy rukhomyi sklad» - Collection of scientific works "Railbound Rolling Stock"*, 25, 7–19. <https://doi.org/10.47675/2304-6309-2022-25-7-19>. [in Ukrainian].
2. Sulym, A.O., Safronov, O.M., Fedosov-Nikonov, D.V., & Strynzha, A. M. (2021). Suchasnyy stan ta perspektyvy rozvytku parku vantazhnykh vahoniv v Ukraini: vidnovlennya chy prodovzhennya vstanovlenoho terminu sluzhby? [The current state and prospects for the development of freight cars fleet in Ukraine: renewal or extension of the designated term of service?] *Zaliznychnyi transport Ukrainy - Railway transport of Ukraine*, 4, 4–20. <https://doi.org/10.34029/2311-4061-2021-141-4-04-20>. [in Ukrainian].
3. Herasymchuk V.H., Lypysiyenko A.P.(2018) Tendentsiyi rozvytku mashynobudivnoho kompleksu Ukrainy. [Trends in the development of the machine-building complex of Ukraine.] *Naukovyy visnyk Uzhhorodskoho natsionalnoho universytetu. Seriya «Mizhnarodni ekonomichni vidnosyny ta svitove hospodarstvo» - Scientific Bulletin of the Uzhhorod National University. Series "International economic relations and world economy"*. Uzhhorod, 19. Part 1, 75–79. [in Ukrainian]
4. Protokol zasidannya tekhnichnoyi rady Ukrzaliznytsi vid 30 veresnya 2015 r. K., [Protocol of the meeting of the Technical Council of Ukrzaliznytsia dated September 30, 2015. K.], 16. [in Ukrainian].
5. Postanova Kabinetu Ministriv Ukrainy vid 30.12.2015 r. № 1147 «Pro zaboronu vvezennya na mytnu terytoriyu Ukrainy tovariv, yaki vvyizhdzhayut z Rosiyskoyi Federatsiyi» [Resolution of the Cabinet of Ministers of Ukraine dated December 30, 2015 No. 1147 "On the prohibition of importation into the customs territory of Ukraine of goods leaving the Russian Federation"] [Electronic resource]. URL: <https://ips.ligazakon.net/document/KPI51147?an=1>. Title from the screen. [in Ukrainian].
6. Prohrama onovlennya parku vantazhnykh vahoniv startuye z 2022 roku. Nakaz Ministerstva infrastruktury № 647 vid 30.12.2021, zarejestrovano. Ministerstvom yustytysiyi Ukrainy 28.12.2021 [The program to update the fleet of freight cars will start as early as 2022. Order of the Ministry of Infrastructure No. 647 dated 12.30.2021, registered by the Ministry of Justice of Ukraine on 28.12.2021] [Electronic resource] // Ministerstvo infrastruktury Ukrainy. 29 hrudnya 2021 r. Ministry of Infrastructure of Ukraine. December 29, 2021 // URL: <https://mtu.gov.ua/news/33350.html> [in Ukrainian].
7. DR № 0116U007026 Zvit pro NDR. Naukovo-eksperymentalni doslidzhennya tekhnichnykh kharakterystyk vagona-samoskyda modeli 31-4154 z metoyu zaprovadzhennya yoho u vyrobnytstvo. [Report on the SRW. Scientific and experimental

studies of the technical characteristics of the dump truck model 31-4154 with the aim of introducing it into production.] / kerivnyk Sheleyko T.V.; vykonano Ilchyshyn V.V., Strynzha A.M., Khozya P.O. [ta in.]. Kremenчук, DP «UkrNDIV», 2015. 338 s. – head of research Sheleyko T.V.; performed by V.V. Ilchyshyn, A.M. Strynzha, P.O. Khozya. [a.o.]. Kremenчук, SE "UkrNDIV", 2015. 338 p. [in Ukrainian]

8. DR № 0119U102793 Zvit pro NDR. Naukovo-eksperymental'ni doslidzhennya tekhnichnykh kharakterystyk vahona-platformy dlya velykotonnazhnykh konteyneriv modeli 13-6961 (zaklyuchnyy) [Report on the SRW. Scientific and experimental studies of the technical characteristics of the flat car for large-tonnage containers model 13-6961 (final)]; kerivnyk Safronov O.M.; vikon. Ilchyshyn V.V., Sheleyko T.V., Khozya P.O., [ta in.]. Kremenчук, DP «UkrNDIV», 2017. 215 s. – head of research Safronov O.M.; performed by Il'chyshyn V.V., Sheleyko T.V., Khozya P.O., [a.o.]. Kremenчук, SE "UkrNDIV" 2017. 215 p. [in Ukrainian]

9. DR № 0119U102806 Zvit pro NDR. Naukovo-eksperymental'ni doslidzhennya tekhnichnykh kharakterystyk vagona –khopera modeli 19-4152 dlya zerna ta inshykh kharchovykh vantazhiv [Report on the SRW. Scientific and experimental studies of the technical characteristics of hopper car for grain and other food cargo] / kerivnyk Ilchyshyn V.V., vykon. Sheleyko T.V., Khozya P.O., Strynzha A.M., [ta in.]. Kremenчук, DP «UkrNDIV», 2017. 248 s. - head of research Ilchyshyn V.V., performed by Sheleyko T.V., Khozya P.O., Strynzha A.M., [a.o.]. Kremenчук, SE «UkrNDIV», 2017. 248 p. [in Ukrainian]

10. DR № 0121U114037 Zvit pro NDR. Naukovo-eksperymentalni doslidzhennya tekhnichnykh kharakterystyk vahona-samoskyda modeli 32-852533-7141 na tryvisnykh vizkakh modeli 18-7142 [Report on the SRW. Scientific and experimental studies of the technical characteristics of dumpcars model 32-852533-7141 on three-axle bogies of the model 18-7142] / kerivnyk Khozya P.O.; vykon. Es'kov D.I., Il'chyshyn V. V., Breslavets' T. A. [ta in.]. Kremenчук, DP «UkrNDIV» 2020. 309 s.- head of research P.O.; performed by Eskov D.I., Ilchyshyn V. V., Breslavets T. A. [a.o.]. Kremenчук, SE «UkrNDIV» 2020. 309 p. [in Ukrainian]

11. DR № 0113U007016 Otchet o NIR. Eksperymental'nyye issledovaniya konstrukttsii vagona-khopera dlya zerna i drugikh pishchevykh gruzov modeli 19-9951 s tsel'yu postanovki na proizvodstvo (zaklyuchitel'nyy) [Research report. Experimental studies of the design of a hopper car for grain and other food cargo model 19-9951 with the aim of putting it into production (final)] / kerivnyk Il'chyshyn V.V., vykon. Tkachev V. I., Shapoval A. V., Grechko A. V., [ta in.]. Kremenчук, DP «UkrNDIV», 2012. 209 p. [in Russian]

12. DR № 0114U001899 Zvit pro NDR. Doslidzhennya mitsnosnykh konstrukttsiyi vahona-platformy modeli 13-4147 (zaklyuchnyy) [Report on the SRW. Study of the strength structures of the flat car model 13-4147 (final)] / kerivnyk Fedosov-Nikonov D.V.; vykon. Donchenko A.V., Ilchyshyn V.V., Tkachev V.I. [ta in.]. Kremenчук, DP «UkrNDIV», 2013. 62 s. – head of research Fedosov-Nikonov D.V. performed by Donchenko A.V., Ilchyshyn V.V., Tkachev V.I. [a.o.]. Kremenчук, SE «UkrNDIV», 2013. 62 p.; [in Ukrainian]

13. Fomin, O., & Lovska, A. (2021). Doslidzhennya dynamichnoyi navantazhenosti vahona-platformy zchlenovanoho typu kruhlykh trub, zavantazhenoho konteyneramy-tsysternamy [Study of the dynamic loading of an articulated round-tube flat car loaded with tank containers.] *Zbirnyk naukovykh prats DUIT. Seriya «Transportni systemy i tekhnolohii» - Collection of scientific papers DUIT. "Transport systems and technologies" series*, 37. 31–40. <https://doi.org/10.32703/2617-9040-2021-37-4>. [in Ukrainian]

14. Fomin, O., Lovska, A., Skliarenko, I., Klochkov, Y.U. (2020). Substantiating the optimization of the load-bearing structure of a hopper car for transporting pellets and hot agglomerate. *Eastern-European Journal of Enterprise Technologies*. 1(7(103)), 65-74 <https://doi.org/10.15587/1729-4061.2020.193408>. [in Ukrainian].

15. Panchenko, S.V., Martynov, I.E., Mozheiko, E.R., Safronov, O.M., & Trufanova, A.V. (2021). Kryti vahony: monohrafiya [Boxcars: monography]. *Kremenчук: SE "UkrNDIV"*, 210. [in Ukrainian]

16. Reidemeister, O.H., Kalashnyk, V. O., Shykunov, O. A. (2016). Modernization as a way to improve the use of universal cars. *Nauka ta prohres transportu. Visnyk Dnipropetrovskoho natsionalnoho universytetu zaliznychnoho transportu - Science and progress of transport. Bulletin of the Dnipropetrovsk National University of Railway Transport*. 2(62), 148 – 156. <https://doi.org/10.15802/stp2016/67334>. [in Ukrainian]

17. Sulym, A.O., Safronov, O.M., Khozya, P.O., Fomin, O.V., & Fomin V.V. (2021) Suchasni innovatsiyi bunkerni vahony-khopery dlya perevezennya zerna vitchyznyanoho vyrobnytstva ta perspektyvy yikh rozvytku. [Modern innovative hopper wagons for grain transportation of domestic production and prospects for their development.] *Naukovi visti Dalivskoho universytetu – Scientific news of Dal University*, 21. <https://doi.org/10.33216/2222-3428-2021-21-16>. [in Ukrainian]

18. Fomin, O., Lovska, A., Daki, O., Bohomia, V., Tymoshchuk, O., & Tkachenko, V. (2019). Determining the dynamic loading on a open-top wagon with a two-pipe girder beam. *Eastern-European Journal of Enterprise Technologies*. 3(7(99)), 18–25. <https://doi.org/10.15587/1729-4061.2019.166329>

19. Kelrikh, M., & Fomin, O. (2014). Perspective directions of planning carrying systems of gondolas. *Metallurgical and Mining Industry*, 6. 64–67.

20. Fedosov-Nikonov, D. V., Sulym, A. O., Ilchyshyn, V. V., Safronov, O. M., & Kelrikh, M. B. (2020, November). Study of strength characteristics of the long wheelbase flat cars. In *IOP Conference Series: Materials Science and Engineering* (Vol. 985, No. 1, p. 012029). IOP Publishing. <https://doi.org/10.1088/1757-899X/985/1/012029>.

21. Kelrikh, M.B., & Fedosov-Nikonov, D.V. (2016). Doslidzhennya na mitsnist konstrukttsiyi dovhobazovoyi platformy. [Study of strength of the long-base platform structure.] *Visnyk Skhidnoukrainskoho natsionalnoho universytetu imeni V. Dalia - Bulletin of the Eastern Ukrainian National University named after V. Dahl*. 1(225), 90–94. [in Ukrainian].

22. Kebal, Y.V., Shatov, V.A., Tyokotev, O.M., & Murashova, N.G. (2017). Udoskonalennya konstrukttsiyi vahona-khopera dlya perevezennya zerna. [Improvement of hopper car design for grain transportation.] *Zbirnyk naukovykh prats*

*DUIT. Seriiia «Transportni systemy i tekhnologii» - Collection of scientific papers DUIT. "Transport systems and technologies" series.* 30, 113–122 [in Ukrainian].

23. Panchenko, S., Fomin, O., Vatulia, G., Ustenko, O., & Lovska, A. (2021). Determining the load on the long-based structure of the platform car with elastic elements in longitudinal beams. *Eastern-European Journal of Enterprise Technologies*. 1(7(109)), 6–13. <https://doi.org/10.15587/1729-4061.2021.224638>.

24. Placzek, M., Wróbel, A., & Buchacz, A. (2016) Placzek, M., Wróbel, A., & Buchacz, A. (2016, November). A concept of technology for freight wagons modernization. In *IOP Conference Series: Materials Science and Engineering* (Vol. 161, No. 1, p. 012107). IOP Publishing. <https://doi.org/10.1088/1757-899X/161/1/012107>.

25. Myamlin, S.V., Murashova, N.G., Kebal, I.Yu., & Kazhkenov, A.Z. (2015). Sovershenstvovanye konstruktivnykh krytykh vahoniv. [Improving the design of covered cars.] *Vahonnyi park - Car fleet*, 7-8 (100-101), 4-8 [in Ukrainian].

26. Koshel, O., Sapronova, S., Kara, S. (2023). Revealing patterns in the stressed-strained state of load-bearing structures in special rolling stock to further improve them. *Eastern-European Journal of Enterprise Technologies*. 4(7(124)), 30–42. <https://doi.org/10.15587/1729-4061.2023.285894>.

27. Neduzha, L.O., Shvets, A.O. (2018). Teoretychni ta eksperymentalni doslidzhennya mitsnisnykh yakostey khrebtovoyi balky vantazhnoho vahona. [Theoretical and experimental studies of the strength qualities of the ridge beam of a freight car.] *Nauka ta prohres transportu. Visnyk Dnipropetrovskoho natsionalnoho universytetu zaliznychnoho transportu - Science and progress of transport. Bulletin of the Dnipropetrovsk National University of Railway Transport*. 1(73), 131 – 147. <https://doi.org/10.15802/stp2018/123457>. [in Ukrainian]

28. Petrenko, V.O., Kellrich, M.B., Prokopenko, P.M., & Kara, S.V. (2022) Otsinka nesivnoyi zdatnosti modernizovanoi ramy vahona-zernovoza. [Evaluation of the carrying capacity of the modernized grain car frame.] *Zaliznychnyi transport Ukrainy - Railway transport of Ukraine*. 3, 4-10. <https://doi.org/10.34029/2311-4061-2022-144-3-04-10>. [in Ukrainian].

29. Fomin, O.V., Lovska, A.O., & Rybin, A.V. (2021) Doslidzhennya pozdovzhoyi navantazhuvanosti vahona-platformy z napovnyuvachem u nesuchiy konstruktivnyy. [Study of the longitudinal load of a flat car with a filling in the supporting structure.] *Naukovi visti Dalivskoho universytetu – Scientific news of Dahl University*, 21. <https://doi.org/10.33216/2222-3428-2021-21-17>.

30. Panchenko, S.V., Fomin, O.V., Vatulya, G.L., Lovska, A.O. Deryzemlya, S.V., & Rybin, A.V. (2021). Obgruntuvannya vykorystannya napovnyuvachiv u skladovykh nesuchykh konstruktivnykh vantazhnykh vahoniv. [Justification of the use of fillers in the load-bearing structures components of freight cars.] *Zbirnyk naukovykh prats DUIT. Seriiia «Transportni systemy i tekhnologii» - Collection of scientific papers DUIT. "Transport systems and technologies" series.* 38. 5–13. <https://doi.org/10.32703/2617-9040-2021-38-5-1>. [in Ukrainian].

31. Panchenko, S., Fomin, O., Vatulia, G., Lovska, A., Bahrov, O., Fedosov-Nikonov, D., & Rybin, A. (2021) Defining patterns in the dynamic load and strength of the bearing structure of a covered freight car with a filler in the girder beam. *Eastern-European Journal of Enterprise Technologies*. 6(7(114)), 68–76. <https://doi.org/10.15587/1729-4061.2021.243866>.

32. Shaposhnyk ,V.YU., & Shykunov, O.A. (2021). Problema obryviv avtozchepiv. [The problem of broken couplings.] *Zbirnyk naukovykh prats DUIT. Seriiia «Transportni systemy i tekhnologii» - Collection of scientific papers DUIT. "Transport systems and technologies" series,* 37, 21–30. <https://doi.org/10.32703/2617-9040-2021-37-3> [in Ukrainian]

33. Ravlyuk, V.H. Modernizatsiya elementiv hal'movoyi vazhil'noyi peredachi vizkiv vantazhnykh vahoniv (2019). [Modernisation of brake lever gear elements for freight car bogies.] *Nauka ta prohres transportu. Visnyk Dnipropetrovskoho natsionalnoho universytetu zaliznychnoho transportu - Science and progress of transport. Bulletin of the Dnipropetrovsk National University of Railway Transport*, 5(83), 108–121. <https://doi.org/10.15802/stp2019/182013>. [in Ukrainian]

34. Muradyan, L.A., Shaposhnyk, V.YU., Vinstrot, B.U., & Mukovoz, S.P. (2015). Ispytaniya perspektivnykh tormoznykh kolodok na zheleznykh dorohakh Ukrainy. [Tests of perspective brake pads on Ukrainian railways.] *Lokomotiv-inform- Locomotive-inform*, 7-8(109-110), 20-22. [in Ukrainian]

35. Gerlici, J., Gorbunov, M., Kravchenko, K., Prosvirova, O., & Lack, T. (2020). Evaluation of innovative methods of modern rolling stock brake systems efficiency increase. *Zaliznychnyi transport Ukrainy - Railway transport of Ukraine*. 2(132), 33–40. <https://doi.org/10.34029/2311-4061-2020-135-2-33-40>. [in Ukrainian].

36. Safronov, O.M., Vodyannikov, YU.YA., Yes'kov, D.I., & Kukin, S.V. (2022). Alhorytm vyznachennya parametra vantazhnoyi peredachi hal'movoyi systemy vantazhnykh vahoniv. [Algorithm for determining the lever gear parameter of the brake system of freight cars.] *Zbirnyk naukovykh prats «Reikovy rukhomiy sklad» - Collection of scientific works "Railbound Rolling Stock"*, 25, 98–114. <https://doi.org/10.47675/2304-6309-2022-25-98-114>. [in Ukrainian].

37. Shvets, A.O. (2022). Doslidzhennya mitsnosti avtozcheplyennya pry netsentralniy vzayemodiyi vahoniv. [Study of the strength of a car coupling in non-central interaction of cars.] *Problemy mitsnosti - Problem of strength*, 2, 77–87. [in Ukrainian]

38. Lobanov, L.M., Makhnenko, O.V., Pavlovs'ky, V.I., Saprykina, H.YU., & Pustovoy, A.D. (2022). Perevahy sutsil'nozvarnoyi konstruktivnyy bokovoyi ramy vizka vantazhnoho vahona. [Advantages of the all-welded construction of the side frame of the freight car bogie.] *Nauka ta prohres transportu. Visnyk Dnipropetrovskoho natsionalnoho universytetu zaliznychnoho transportu - Science and progress of transport. Bulletin of the Dnipropetrovsk National University of Railway Transport*, 3-4(99-100), 55–69. <https://doi.org/10.15802/stp2022/276541>. [in Ukrainian].

39. Mankevich, N.B. (2014). Dynamics of freight cars on bogies model 18-1711 with different designs of spring suspension wedges. *Science and progress of transport. Bulletin of the Dnipropetrovsk National University of Railway Transport*, 1(49), 142–150.

40. Kara, S.V. (2017). Udoshkonalennya konstruktsiyi bokovoyi ramy tr'okhelementnoho vizka vantazhnoho vahona. [Improvement of the side frame design of the three-element bogie of a freight car.] *Zaloznychnyi transport Ukrainy –Railway transport of Ukraine*, 1, 32–35. [in Ukrainian].
41. Bahrov, O.M. (2016). Bokovi ramy vizkiv vantazhnykh vahoniv. Eksploatatsiya. Problemy ta yikh vyrishennya. [Side frames of freight cars. Operation. Problems and their solutions.] *Zaloznychnyi transport Ukrainy –Railway transport of Ukraine*, 1-2, 29–34. [in Ukrainian].
42. Golubenko, A.L., Gubacheva, L.A., Andreyev, A.A., & Mokrousov, S.D. (2013). Features of freight car bogie frame and fatigue endurance. *Bulletin of the Eastern Ukrainian National University named after V. Dahl*, 1(9), 7–16. [in Ukrainian].
43. Martynov, I.E., Trufanova, A.V., Shovkun, V.O., & Sharyy, O.L. (2023) Analiz konstruktsiy korpusiv buks vantazhnykh vahoniv. [Analysis of freight car axle box structures.] *Komunal'ne hospodarstvo mist. - Communal management of cities*, 175, 229–236. <https://doi.org/10.33042/2522-1809-2023-1-175-229-236>. [in Ukrainian].
44. Shykunov, O.A. (2017) Three-element bogie side frame strength. *Nauka ta prohres transportu. Visnyk Dnipropetrovskoho natsionalnoho universytetu zaloznychnoho transportu - Science and progress of transport. - Bulletin of the Dnipropetrovsk National University of Railway Transport*, 1(67), 183–193. <https://doi.org/10.15802/stp2017/92535>.
45. Muradyan, L.A., Babayev, A.M., Shaposhnik, V.YU., & Mishchenko, A.A. (2018). About the experience of using the DIIT-UZ profile in modernized freight car bogies. *Collection of scientific papers DUIT. "Transport systems and technologies" series*, 32(1), 45–54.
46. Gorbunov, M., Gerlici, J., Kara, S., Nozhenko, O., Chernyak, G., Kravchenko, K., Lack T. (2018). New Principle Schemes of Freight Cars Bogies. *Manufacturing Technology*, 18(2), 233-238. <https://doi.org/10.21062/ujep/83.2018/a/1213-2483/MT/18/2/233>.
47. Dižo, J., Harušinec, J., & Blatnický, M. (2017). Structural analysis of a modified freight wagon bogie frame. In *MATEC Web of Conferences* (Vol. 134, p. 00010). EDP Sciences. <https://doi.org/10.1051/mateconf/201713400010>.
48. Šťastniak, P., Moravčík, M., & Smetanka, L. (2019). Investigation of strength conditions of the new wagon prototype type Zans. In *MATEC Web of Conferences* (Vol. 254, p. 02037). EDP Sciences. <https://doi.org/10.1051/mateconf/201925402037>.
49. Fomin, O., Lovska, A., Lytvynenko, A., & Sova, S. (2022). Determining the features of loading the bearing structure of a multifunctional car under operating modes. *Eastern-European Journal of Enterprise Technologies*, 3(7(117)), 6–13. <https://doi.org/10.15587/1729-4061.2022.258201>.
50. Chuan-Jin, O. U., & Bing-Tao, L. I. (2020). Research and application of new multimodal transport equipment-swap bodies in China. In *E3S Web of Conferences* (Vol. 145, p. 02001). EDP Sciences. <https://doi.org/10.1051/e3sconf/202014502001>.
51. Wiesław, K., Tadeusz, N., & Michał, S. (2016). Innovative Project of Prototype Railway Wagon and Intermodal Transport System. *Transportation Research Procedia*, 14, 615–624. <https://doi.org/10.1016/j.trpro.2016.05.307>.
52. Šťastniak, P., Kurčík, P., & Pavlík, A. (2018). Design of a new railway wagon for intermodal transport with the adaptable loading platform. In *MATEC Web of Conferences* (Vol. 235, p. 00030). EDP Sciences. <https://doi.org/10.1051/mateconf/201823500030>.
53. Stoilov, V., Simić, G., Purić, S., Milković, D., Slavchev, S., Radulović, S., & Maznichki, V. (2019, October). Comparative analysis of the results of theoretical and experimental studies of freight wagon Sdggmrss-twin. In *IOP Conference Series: Materials Science and Engineering* (Vol. 664, No. 1, p. 012026). IOP Publishing. <https://doi.org/10.1088/1757-899x/664/1/012026>.
54. Krason, W., & Niezgoda, T. (2014). FE numerical tests of railway wagon for intermodal transport according to PN-EU standards. *Bulletin of the Polish Academy of Sciences Technical Sciences*, 62(4), 843–851. <https://doi.org/10.2478/bpasts-2014-0093>.
55. Fabian, P., Gerlici, J., Masek, J., & Marton, P. (2013). Versatile, Efficient and Long Wagon for Intermodal Transport in Europe. *Communications - Scientific Letters of the University of Zilina*, 15(2), 118–123. <https://doi.org/10.26552/com.C.2013.2.118-123>.
56. Patlasov, O.M., & Fedorenko, YE.M. (2021). Dopustymi znachennya dynamichnoyi diyi rukhomoho skladu na zaloznychnu kolyu u razi pidvishchennya os'ovoho navantazhennya. [Permissible values of the dynamic action of the rolling stock on the railway track in case of suspension of the axial load.] *Nauka ta prohres transportu. Visnyk Dnipropetrovskoho natsionalnoho universytetu zaloznychnoho transportu - Science and progress of transport. Bulletin of the Dnipropetrovsk National University of Railway Transport*, 3(93), 15–23. <https://doi.org/10.15802/stp2021/242048>. [in Ukrainian].
57. Myamlin, S.V. (2019). Design features and implementation of rolling stock with a load of 25 tons per axle. *Railway transport of Ukraine*, 3, 21–28. <https://doi.org/10.34029/2311-4061-2019-132-3-21-28>. [in Ukrainian].
58. Bubnov, V., Myamlin, S., & Mankevych, N. (2013) Theoretical and experimental investigations of strength properties of cast parts for freight cars bogie with axle load 245 kN, *Proc. 8th Int. Conf., Vilnius Lithuania*, 9-12. <https://doi.org/10.3846/transbaltica2013.003>.
59. Patlasov, O.M., & Fedorenko, YE.M. (2019). Vplyv vahoniv z os'ovym navantazhennyam 25 ts/vis' na stan zaloznychnoyi kolyi [Influence of wagons with an axle load of 25 tf/axle on the state of the railway track.] *Nauka ta prohres transportu. Visnyk Dnipropetrovskoho natsionalnoho universytetu zaloznychnoho transportu - Science and progress of transport. Bulletin of the Dnipropetrovsk National University of Railway Transport*, 3(81), 87–95. <https://doi.org/10.15802/stp2019/171297>. [in Ukrainian].

60. Safronov, A.M., Sulym, A.A., Khozya, P.A., Vodyannikov, YU.YA., & Stoletov, S.A. (2019). The influence of the design features of bogies models 18-4129 and 18-9817 with an axle load of 25 tf on the dynamic performance of freight cars. *Collection of scientific papers DUIT. "Transport systems and technologies" series*, 33. Vol. 1. 171–178. DOI: <https://doi.org/10.32703/2617-9040-2019-33-1-15>.
61. Ilchyshyn V.V., A.M. Stringha, V.A. Khudienko, D.V. Fedosov-Nikonov, V.M. Poluliakh, S.V. Dolinskyi. (2018). Teoretychni ta eksperymental'ni doslidzhennya mitsnosti innovatsiyanoi konstruktsiyi bunkernoho vahona. [Theoretical and experimental studies of the strength of the innovative structure of the bunker car.] *Zbirnyk naukovykh prats «Reikovy rukhomiy sklad» - Collection of scientific works "Railbound Rolling Stock"*. 17. 79–86. [in Ukrainian]
62. Kostyrytsia, S.A., Fedorov, E.F., Bolotov, V.V., & Granovska, N.Y. (2021, April). Khodovi dynamichni ta mitsnisni vyprobuvannya vahona-platformy modeli 13-7133 na vizkakh z kovzunamy zazornoho typu dlya perevezennya krupnotonazhnykh konteyneriv. Problemy ta perspektyvy rozvytku zaliznychnoho transportu: materialy 81 Mizhnarodnoyi naukovo-praktychnoyi konferentsiyi, 22-23 kvitnya. [Problems and prospects of the development of railway transport: materials of the 81st International Scientific and Practical Conference, April 22-23] 2021 p. / za zah. red. A.V. Radkevycha, R.V. Rybalky. Dniprov. nats. un-t. zaliznych. transp. im. akad. V. Lazaryana. Dnipro, 2021. (pp. 307–308).
63. Khozya, P.O., Yushko, O.O., Orlov, O.V., Khvoyenko, E.O., & Hryhoroshenko M.V. (2022). Naukovo-eksperymental'ni doslidzhennya tekhnichnykh kharakterystyk vahona-samoskyda modeli 33-7141. [Scientific and experimental studies of the technical characteristics of the dump truck model 33-7141.] *Zbirnyk naukovykh prats «Reikovy rukhomiy sklad» - Collection of scientific works "Railbound Rolling Stock"*, 25, 129–143. <https://doi.org/10.47675/2304-6309-2022-25-129-143>.
64. Sulym, A.O., Khozya, P.O., Strynzha, A.M., Rechkalov, V.S., & Fedorov, V.V. (2022). Shlyakhy ta perspektyvy udoskonalennya vahoniv-dumpkariv, pryznachenykh dlya ekspluatatsiyi mahistral'nymy kolyamy 1520 mm. [Ways and prospects of improvement of dump cars intended for operation on 1520 mm main tracks.] *Zbirnyk naukovykh prats DUIT. Seriya «Transportni systemy i tekhnolohii» - Collection of scientific papers DUIT. "Transport systems and technologies" series*, 39, 51–65. <https://doi.org/10.32703/2617-9040-2019-39-6>. [in Ukrainian]
65. Donchenko, A.V., & Safronov, O.M. (2016). Vymohy do formuvannya typorozmirnogo ryadu vahoniv novoho pokolinnya dlya zabezpechennya proviznoyi spromozhnosti zaliznyts. [Requirements for the formation of standard-sized series of new generation cars to ensure the carrying capacity of railways.] *Zbirnyk naukovykh prats «Reikovy rukhomiy sklad» - Collection of scientific works "Railbound Rolling Stock"*, 13, 41–44. [in Ukrainian]
66. Vatulia, G., Falendysh, A., Orel, Y., & Pavliuchenkov, M. (2017). Structural Improvements in a Tank Wagon with Modern Software Packages. *Procedia Engineering*, 187, 301–307. <https://doi.org/10.1016/j.proeng.2017.04.379>.
67. Fomin, O.V., Gorbunov, M.I., Kara, S.V., Prokopenko, P.M., & Gryndey, P.O. (2020). Stvorennya vysokotochnoyi rozrakhunkovoyi modeli tr'okhelementnoyi konstruktsiyi vizka vantazhnoho vahona. [Creation of a highly accurate calculation model of a three-element design of a freight car trolley.] *Zbirnyk naukovykh prats DUIT. Seriya «Transportni systemy i tekhnolohii» - Collection of scientific papers DUIT. "Transport systems and technologies" series*, 36, 104–111. <https://doi.org/10.32703/2617-9040-2020-36-11>.
68. Lovska, A.O. (2023). Komp'yuterne modelyuvannya mitsnosti nesuchoyi konstruktsiyi vahona-khopera dvosektsiynoho. [Computer modeling of supporting structure strength of a two-section hopper car.] *Naukovi visti Daliv's'koho universytetu – Scientific news of Dahl University*, 24, 1-6. <https://doi.org/10.33216/2222-3428-2023-24-11>. [in Ukrainian]
69. Myamlin, S.S. (2020). Mathematical model of spatial vibrations of a four-axle flat car on bogies with elastic coupling of wheel pairs and side frames. *Railway transport of Ukraine*, 3(136), 43-50. <https://doi.org/10.34029/2311-4061-2020-136-3-43-50>.
70. Rechkalov, V.S., Rechkalov, S.D., Ilchishin, V.V., & Solyanik, M.I. (2018). Calculation dependencies for studying vertical vibrations of the boiler shell of railway tanks, taking into account design features. *Collection of scientific works "Railbound Rolling Stock"*, 16, 70–76.
71. Safronov, A.M., Vodyannikov, Yu.Ya., & Makeeva, E.G. (2018) *Tormoznaya effektivnost' gruzovykh vagonov. Metodologiya raschetnykh i eksperimentalnykh issledovaniy s ispol'zovaniyem matematicheskikh modeley i komp'yuternogo modelirovaniya: monografiya*. [Braking efficiency of freight cars. Methodology of computational and experimental studies using mathematical models and computer simulation monograph]. Kremenchug: SE "UkrNIIV". [in Ukrainian].
72. Lee, H.-A., Jung, S.-B., Jang, H.-H., Shin, D.-H., Lee, J. U., Kim, K. W., & Park, G.-J. (2015). Structural-optimization-based design process for the body of a railway vehicle made from extruded aluminum panels. *Proceedings of the Institution of Mechanical Engineers, Part F: Journal of Rail and Rapid Transit*, 230(4), 1283–1296. <https://doi.org/10.1177/0954409715593971>.
73. Lovska, A. (2018). Simulation of loads on the carrying structure of an articulated flat car in combined transportation. *International Journal of Engineering & Technology*, 7(4.3), 140–146. <https://doi.org/10.14419/ijet.v7i4.3.19724>.
74. Nandan, S., Trivedi, R., Kant, S., Ahmad, J., & Maniraj, M. (2020). Design, analysis and prototype development of railway wagons on different loading conditions. *International Journal of Engineering Applied Sciences and Technology*, 4(10), 122-129. <https://doi.org/10.33564/ijeast.2020.v04i10.023>.
75. Dyomin, Yu.V., Chernyak, G.Yu., & Shevchuk, P.A. (2017). Computer models of the dynamics of the wheel of flatcars on bogies with central and axle suspensions. *Visnyk Shkhidnoukrainskoho natsionalnoho universytetu imeni V. Dalia - Bulletin of the Eastern Ukrainian National University named after V. Dahl*, 5(235), 41–45.

**Андрій Сулим<sup>1\*</sup>, Олександр Сафонов<sup>2</sup>, Андрій Стринжа<sup>3</sup>, Павло Хозя<sup>4</sup>**

<sup>1</sup>Заступник директора з наукової роботи, Державне підприємство «Український науково-дослідний інститут вагонобудування», вул. І. Приходька, 33, м. Кременчук, 39621, Україна. ORCID: <https://orcid.org/0000-0001-8144-8971>.

<sup>2</sup>Директор, Державне підприємство «Український науково-дослідний інститут вагонобудування», вул. І. Приходька, 33, м. Кременчук, 39621, Україна. ORCID: <https://orcid.org/0000-0002-5865-7756>.

<sup>3</sup>Завідувач науково-дослідної лабораторії, Науково-дослідна лабораторія вантажного та спеціального рухомого складу, Державне підприємство «Український науково-дослідний інститут вагонобудування», вул. І. Приходька, 33, м. Кременчук, 39621, Україна. ORCID: <https://orcid.org/0000-0003-3743-7006>.

<sup>4</sup>Завідувач науково-дослідної лабораторії, Науково-дослідна лабораторія експериментальних досліджень залізничної техніки, Державне підприємство «Український науково-дослідний інститут вагонобудування», вул. І. Приходька, 33, м. Кременчук, 39621, Україна. ORCID: <https://orcid.org/0000-0001-8948-6032>.

### **Шляхи удосконалення конструкції вантажних вагонів**

*В статті наведено динаміку виробництва вітчизняними підприємствами вантажних вагонів за роками. Обґрунтовано необхідність оновлення вітчизняного експлуатаційного парку вантажних вагонів. Встановлено такі основні вектори удосконалення конструкції за результатами постановки на виробництво нових та модифікованих моделей вантажних вагонів: використання сталей підвищеної міцності у несучих елементах конструкції та інноваційних комплектуючих; удосконалення існуючих та створення принципово нових несучих конструкцій; максимально ефективного використання габариту; розроблення вантажних вагонів з осьовим навантаженням 25 тс; створення багатофункціональних конструкцій; підвищення міцності конструкцій довгобазних вагонів-платформ; застосування новітніх технологій збірки та зварювання. Визначено такі основні вектори удосконалення конструкції вагонів за результатами аналізу науково-прикладних досліджень, окрім вищезазначених: застосування нових матеріалів; створення шестивісних вагонів зчленованого типу з осьовим навантаженням 23,5 тс та 25 тс; розроблення вагонів з використанням візків та комплектуючих деталей до них нового покоління; досягнення рівномірного навантаження несучої конструкції; створення конструкції вагонів-платформ для перевезення контейнерів в два яруси; розроблення нових вагонів для інтермодальних, інтеперабельних, комбінованих перевезень.*

**Ключові слова:** вантажний вагон, конструкція, парк, рухомий склад, удосконалення.