

UDC 621.33: 629.4

Ievgen Riabov^{1*}, Liliia Overianova², Kostiantyn Ivanov³, Iryna Bilokon⁴, Anton Zhukov⁵

¹ Assistant professor, Department of Electric Transport and Locomotive Engineering, National Technical University «Kharkiv Polytechnic Institute», Kyrpychova str. 2, Kharkiv, 61002, Ukraine
ORCID: <https://orcid.org/0000-0003-0753-514X>.

² Assistant professor, Department of Electric Transport and Locomotive Engineering, National Technical University «Kharkiv Polytechnic Institute», Kyrpychova str. 2, Kharkiv, 61002, Ukraine
ORCID: <https://orcid.org/0000-0002-4827-572X>.

³ Postgraduate student, Department of Electric Transport and Locomotive Engineering, National Technical University «Kharkiv Polytechnic Institute», Kyrpychova str. 2, Kharkiv, 61002, Ukraine
ORCID: <https://orcid.org/0009-0000-3000-8191>.

⁴ Director, Kremenchuk Applied College of Transport Infrastructure and Technology, 14, Yuri Ruf str., Kremenchuk, Poltava Region, 39600, Ukraine. ORCID: <https://orcid.org/0000-0002-4675-3994>.

⁵ LLC «Kharkiv Electric Machine-Building Plant», Avenue of Heroes of Kharkiv, 199, Kharkiv, 61037, Ukraine ORCID: <https://orcid.org/0009-0001-5229-1685>

*Corresponding author: riabov.ievgen@gmail.com.

Development of a Hybrid Traction System for a Suburban Multiple Electric Train with Dual Power Supply

This paper examines and analyses the design options for traction systems of modern electric rolling stock. Traction systems based on traditional circuit design solutions are reviewed and discussed. A review of traction systems with converters using medium-frequency transformers is provided. The use of such transformers reduces the weight of electrical equipment, requires less installation space, and increases the energy efficiency of electric rolling stock. It is shown that a priority approach is to use a hybrid traction system based on traditional circuit solutions, as its components exhibit high reliability. Several variants of hybrid traction systems for a dual-supply suburban electric train are proposed. The study demonstrates the feasibility of stabilising the intermediate circuit voltage to ensure autonomous energy exchange between the energy storage system and the traction drive. The operation of the circuits is described, and it is shown that when the intermediate DC-link voltage does not exceed 1000 V, standard industrial solutions can be used in the energy storage system. The proposed hybrid traction systems can be implemented in the modernisation or development of new electric multiple units and may also be used in other types of rail vehicles.

Keywords: *electric rolling stock, energy efficiency, hybrid traction system, traction electric drive, energy storage device, traction converter, traction transformer, traction asynchronous motor.*

Introduction. Suburban railway transport plays a crucial role in the functioning of large urban agglomerations. By providing daily commuting for work and social purposes, suburban rail transport contributes to the integration of suburban areas into the socio-economic space of cities [1]. According to [2], more than 400 suburban train services operate within metropolitan areas of major regional centres and the capital. However, despite the significant share of suburban transport provided by railways, a declining trend in passenger numbers has been observed. This is linked to several factors affecting the efficiency and competitiveness of suburban rail transport. Among them is the high degree of rolling stock wear, which influences both the technical performance during operation and passenger comfort. In recent years, the rolling stock used for suburban services has been gradually renewed, primarily to

improve passenger comfort, enhance working conditions for locomotive crews, and upgrade safety systems [3]. Nevertheless, the modernised electric multiple units still employ serial traction systems developed more than 50 years ago. Consequently, these trains exhibit increased consumption of fuel and energy resources, which, in conditions of rising energy costs, leads to higher operating expenses for suburban services that are already subsidised [4].

Given the ageing of rolling stock where wear is estimated at 85% and outdated technical solutions that increase maintenance and energy costs, as well as reduce reliability, the renewal of rolling stock or its traction systems has become an urgent necessity. The first approach complete replacement provides the best technical performance and comfort levels but requires substantial capital investment for acquisition, maintenance, and servicing. A more economical alternative is the modernisation of existing rolling stock [5]. Regardless of the chosen approach, the traction system must ensure high energy efficiency, as this directly reduces the consumption and cost of fuel and energy resources.

Almost all suburban transport services in Ukrainian urban agglomerations operate on electrified lines. For direct current sections, electric trains of the series ER2, ER2R, ER2T, ED2T, and EPL2T are used. On alternating current sections, trains of the series ER9, ER9M, ER9E, and EPL9T operate. The most recent models EPL2T and EPL9T were manufactured by PJSC Luhanskteplovoz in the early 2000s. However, their traction equipment is largely inherited from older models, retaining the same shortcomings associated with low energy efficiency. A major disadvantage is the lack of regenerative braking in AC electric trains and most DC ones, despite regeneration being a key technology for energy saving in electric traction systems [6, 7]. However, full utilisation of regenerative energy is only possible when the process is autonomous [8], which can be achieved through the use of onboard energy storage systems. Therefore, the development of a traction system incorporating energy storage for suburban electric trains is a relevant and pressing task.

Analysis of recent research and problem statement. Improvement of electric multiple unit rolling stock is essential for the stable operation of railway transport. Ukrainian researchers have conducted studies aimed at enhancing the traction systems of serial electric trains [9], developing innovative traction systems [10–12], and creating electrical equipment for various types of electric rolling stock [13, 14]. The use of energy storage devices on electric rolling stock has been explored in [15–17]. Certain aspects related to the integration of energy storage systems into rolling stock have been studied in [18–20] and other publications. Unfortunately, most of these works remain theoretical.

Abroad, the technology of onboard energy storage for rail transport has reached the stage of practical implementation. The MITRAC Energy Saver system, developed by Bombardier Transportation, enables energy savings of up to 30% when applied to tram cars. It reduces voltage fluctuations at the pantograph, decreases losses in the traction network, and allows autonomous operation on non-electrified sections [21]. Reference [22] presents test results for the Series EV-E301 train, where an onboard energy storage system powers the train while running on non-electrified tracks. The onboard storage accumulates energy during braking, thus reducing the energy required for recharging from the overhead line or charging station at the terminus.

Experimental tests of the Hi-tram tram car demonstrated the potential to recover up to 41% of the energy consumed for traction [23]. In [24], the results of experimental studies of the BEC-819 electric train are presented; this train was modernised with an onboard energy storage system, which enabled operation on non-electrified lines and accumulation of energy during electrodynamic braking for recharging.

Advances in chemical energy storage technologies have made it possible to develop rolling stock powered by traction batteries. Such vehicles can operate autonomously on non-electrified lines for up to 100 km or more. Examples include Bombardier Talent 3 [25], FLIRT Akku [26], Siemens Mireo Plus B [27], and others. These trains are equipped with high-capacity traction batteries that can be charged from the overhead line, at terminal stations, or through regenerative braking.

A similar class of vehicles includes tram systems operating without overhead contact lines [28]. Such rolling stock uses compact energy storage units that recharge at stops from contactless power sources. Notably, energy storage systems are also used in multiple units with triple-mode power supply [29].

The use of onboard energy storage systems in electric rolling stock is now widespread and serves the following purposes:

1. Accumulation of energy during electrodynamic braking with subsequent use to power onboard systems;
2. Power supply to rolling stock systems during movement along non-electrified sections.

The type and parameters of an onboard energy storage system depend on its intended function [17, 30].

Thus, the analysis confirms the feasibility and efficiency of integrating energy storage systems into electric rolling stock.

To ensure the effective use of onboard storage on Ukrainian multiple units, several operational factors must be considered.

Firstly, Ukrainian railways employ two traction power supply systems:

- Direct current with a nominal voltage of 3 kV;
- Alternating current with a nominal voltage of 25 kV at an industrial frequency of 50 Hz.

The pantograph voltage varies within 2.2–4.0 kV for DC lines and 19–29 kV for AC lines. Therefore, it is rational to unify the traction equipment that does not directly interact with the contact network.

Secondly, since some routes pass through sections electrified under both systems, it is advisable that input equipment can operate with either DC or AC supply.

Thirdly, the traction system must include an onboard energy storage device. As mentioned earlier, for the energy storage system to function effectively, its power flow processes must be autonomous and unaffected by the traction network.

Hence, the requirements outlined above must be taken into account in designing traction systems for multiple-unit rolling stock equipped with onboard energy storage systems.

Purpose and Objectives of the Study. The purpose of this study is to develop and analyse a hybrid traction system for a suburban electric train, taking into account operational conditions and factors.

The main objectives of the research are as follows:

- To analyse existing circuit design solutions used in the traction systems of electric rolling stock;
- To develop a schematic design for a hybrid traction system applicable to a suburban electric train.

Materials and Methods of the Study. The multiple-unit rolling stock currently operated by Ukrzaliznytsia JSC for suburban passenger services is designed to work exclusively with a single traction power supply system. Dual-system trains include Hyundai Rotem HRCS2, Škoda EJ 675, and EKr-1, which are primarily used for Intercity services. Analysis of the technical documentation for these trains indicates that they use the most common traction circuit configuration applied in dual-system rolling stock (Fig. 1a).

In the circuit shown in Fig. 1a, the traction inverter is connected directly to the 3 kV DC network, which necessitates the use of 65-class IGBT transistors [32]. The input four-quadrant converter (4QS) also requires transistors of the same class. When operating from a 25 kV, 50 Hz AC network, a traction transformer and a 4QS converter are used. The main advantages of this circuit are its simplicity and high energy performance. However, a significant drawback is the inability to stabilise the intermediate DC-link voltage when powered from a DC supply. This limitation complicates the integration of an energy storage system, as fluctuations in the intermediate voltage may disrupt energy exchange between the traction drive and the storage unit.

To eliminate voltage fluctuations in the intermediate circuit, chopper-based configurations are required (Fig. 1b and Fig. 1c).

In the circuit shown in Fig. 1b, 65-class IGBTs are used in the 4QS converter, and 65- or 45-class devices in the traction inverter [32]. Under AC supply, the system employs a transformer and a 4QS converter, which stabilises the intermediate voltage. Under DC supply, the IGBTs of the 4QS converter operate in chopper mode, allowing voltage stabilisation as well.

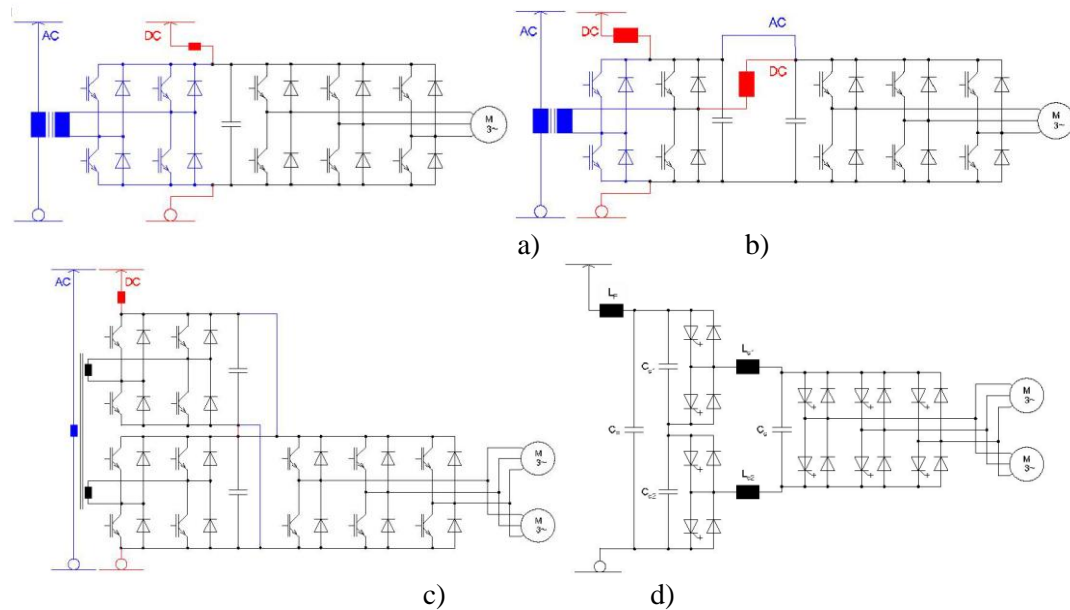

Fig. 1. Traction system schemes of dual-system electric rolling stock

a – non-chopper circuit for operation under DC 3 kV supply [31, 32]; b, c – chopper-based circuits for operation under DC 3 kV supply [31, 32]; d – voltage divider circuit for operation under DC 3 kV supply [34].

In the configuration shown in Fig. 1c, 33-class semiconductor devices may be used in both the 4QS converter and traction inverter. The use of two 4QS converters improves the power quality drawn from the AC network [33]. Thus, the schemes in Fig. 1b and Fig. 1c ensure stable DC-link voltage under both DC and AC operation modes.

It should be noted that when operating from a DC network, additional equipment must be integrated to form a circuit similar to the one shown in Fig. 1c.

An innovative approach to the design of dual-system traction systems involves the use of semiconductor converters with medium-frequency transformers (Power Electronic Transformers – PET, Medium Frequency Topologies or Solid-State Transformers – SST) [35]. These converters employ transformers operating at elevated frequencies. Several prototype devices of this type have already been developed and tested on railway rolling stock.

Fig. 2 presents circuits of converters with medium-frequency transformers that have undergone experimental validation, including on electric traction vehicles

In Fig. 2a, the diagram of the converter developed by Alstom for use on rolling stock supplied from a 15 kV, 16 2/3 Hz traction network is presented.

The technical parameters of the Alstom eTransformer converter are shown in Table 1. Its high-voltage input stage (stages 1 and 2) comprises an input reactor and eight series-connected conversion modules forming an AC–AC converter (multi-level configuration). The first stage is a full H-bridge AC converter, while the second stage is a half-bridge DC converter. The transformer's primary winding is powered through a resonant circuit (capacitor and transformer leakage inductance) tuned to 5 kHz. Although stages 1 and 2 each include eight modules, stage 3 consists of a single H-bridge supplying the low-voltage DC link, equipped with an LC filter. Stage 1 operates with hard switching (since its switching frequency can be relatively low) and uses 6.5 kV/400 A IGBTs. Stage 2 operates with soft switching under quasi-zero current switching (quasi-ZCS) conditions and uses 3.3 kV IGBTs. In the event of a module failure, the faulty unit can be bypassed, allowing continued full-power operation. Both the semiconductors and transformer are cooled using a forced oil circulation system. Despite employing about three times as many semiconductors as traditional line-frequency transformer systems, the eTransformer offers superior power density and efficiency.

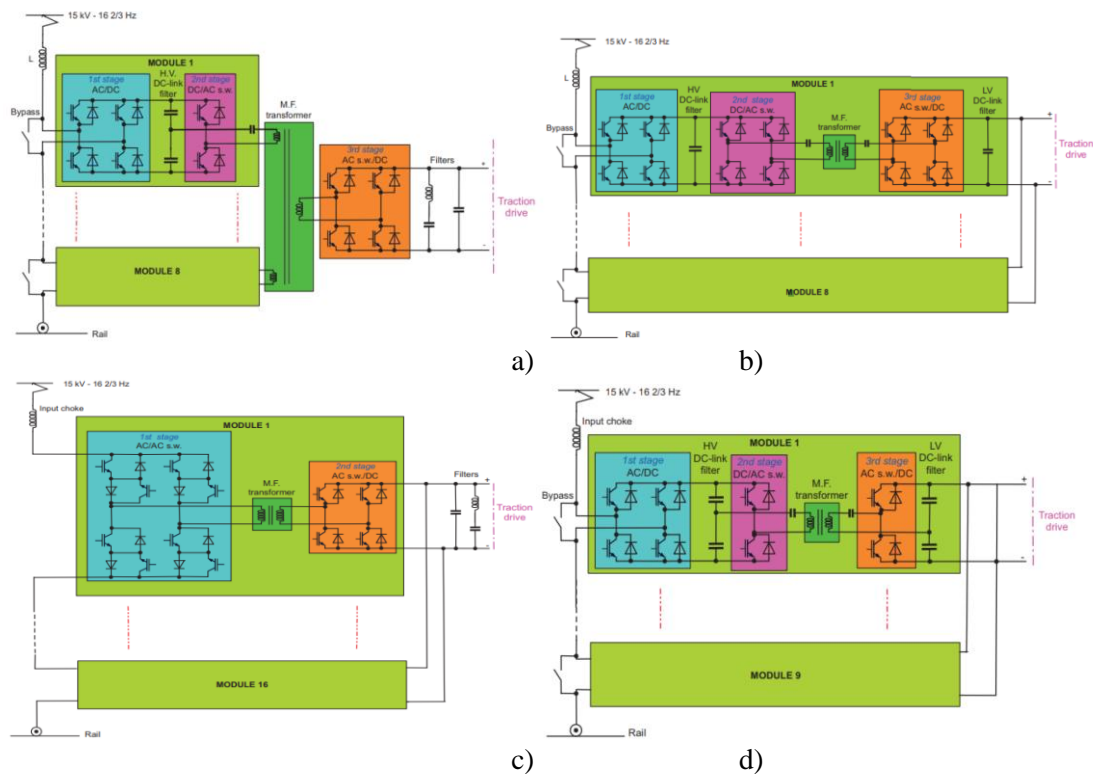

Fig. 2. Traction system schemes with converters employing medium-frequency transformers a – eTransformer circuit developed by Alstom [35]; b – “Medium Frequency Topology” converter developed by Bombardier Transportation [35]; c – ABB converter circuit [35]; d – ABB Power Electronic Traction Transformer [35].

Table 1. Technical parameters of the eTransformer converter [35]

Parameter	Value
Input voltage	15 kV
Input frequency	16.7 Hz
Output voltage	1.65 kV DC
Rating power	1500 kVA
Maximum power	2250 kVA (30 s)
Efficiency	94%
Transformer frequency	5 kHz
Transformer + electronic weight	2830 kg
Output LC filter weight	385 kg
Heat exchanger weight	255 kg
Overall weight	<3600 kg
Power density	0.42 kVA/kg
Total number of IGBTs	52
Cooling system	Forced oil circulation

Fig. 2b shows the “Medium Frequency Topology” converter developed by Bombardier Transportation for operation from a 15 kV, 16 2/3 Hz AC supply.

Similar to the eTransformer, this converter has three cascades consisting of eight identical modules connected in series. Unlike the eTransformer, which employs a single medium-frequency transformer,

in this configuration each module has its own transformer, while the low-voltage DC links of the modules are connected in parallel. The first cascade is a full-bridge AC/DC converter, the second cascade is a full-bridge DC/AC converter (whereas the eTransformer uses a half-bridge), and the third cascade is again a full-bridge AC/DC converter. If one of the modules fails, the topology can continue operation at 7/8 of nominal power. The system uses 6.5 kV IGBTs in the first stage, which means seven modules are sufficient for a 15 kV line voltage. Each transformer weighs only 18 kg and has a 1:1 turns ratio. The main drawback of this configuration is the large number of semiconductor devices and auxiliary components. The number of components can be reduced by using half-bridge topologies, as shown in other designs.

Table 2. Technical parameters of the “Medium Frequency Topology” converter [35]

Parameter	Value
Input voltage	15 kV
Input frequency	16.7 Hz
Output voltage	3.6 kV D
Rating power	3000 kVA
Transformer frequency	8 kHz
Transformers weight*	18 kg
Total number of IGBTs	96
Cooling system	Deionized water

*Weight for each transformer

Fig. 2c presents the ABB converter design. Its parameters are summarised in Table 3. Unlike the previous examples, this converter has two cascades. It uses 3.3 kV, 400 A IGBTs arranged in 16 modules, doubling the number of units compared with other medium-frequency solutions, since lower-voltage transistors are used. Each module includes a 1:1 medium-frequency transformer operating at 400 Hz, which limits the reduction in transformer size. Therefore, the dimensions of this converter remain larger than those of traditional line-frequency transformers with 4QS converters.

Table 3 – Technical parameters of the first ABB prototype converter [35]

Parameter	Value
Input voltage	15 kV
Input frequency	16.7 Hz
Output voltage	1.8 kV DC
Rating power	1200 kVA
Transformer frequency	400 Hz
Total number of IGBTs	192
Cooling system	Forced oil circulation

In terms of efficiency, while this prototype shows about 3% higher efficiency than a traditional transformer under medium and high load, it performs worse at low load conditions. Furthermore, its requirement for 192 IGBTs makes the design heavy and complex; hence, this prototype is now considered obsolete.

Fig. 2d shows the ABB Power Electronic Traction Transformer (PETT), whose parameters are listed in Table 4.

The converter has three cascades and includes nine series-connected modules, one of which serves as a reserve. Each module contains its own medium-frequency transformer. The first cascade is a full H-bridge AC/DC converter using 6.5 kV–400 A IGBTs that supply a 3.6 kV DC link; the second is a half-bridge DC/AC converter employing the same transistor type; and the third is a half-bridge AC/DC converter using 3.3 kV–800 A IGBTs. The resonant circuit (LLC type) uses both magnetising and leakage inductances to achieve resonance, allowing the elimination of the LC filter and minimising size

and weight. Although the power density (0.266 kVA/kg nominal, 0.4 kVA/kg maximum) is still relatively low, the achieved 96% efficiency is substantially higher than that of conventional line-frequency transformer systems with 4QC converters.

Table 4. Technical parameters of the ABB Power Electronic Traction Transformer [35]

Parameter	Value
Input voltage	15 kV
Input frequency	16.7 Hz
Output voltage	1.5 kV DC
Rating power	1200 kVA
Maximum power	1800 kVA
Efficiency	96%
Total number of IGBTs	72
Total weight	4500 kg
Power density	0.266 kVA/kg

It should be emphasised that all analysed medium-frequency converters were designed for 15 kV, 16 2/3 Hz railway networks, where their reduced weight gives a considerable advantage. Nevertheless, despite these benefits, their large-scale adoption in rolling stock has not yet occurred. Medium-frequency converters have found use primarily in traction systems equipped with onboard batteries [36].

Research on medium-frequency converters for 25 kV, 50 Hz systems remains largely theoretical, focusing on various design aspects [37–39].

Ukrainian studies [10, 12] also explored their application in domestic dual-system electric trains, proposing suitable circuit structures and calculating key parameters. Thus, while these converters are not yet in operational use on traction rolling stock, their lower mass and volume make them attractive, especially when onboard energy storage systems—requiring significant space and weight—are to be installed.

Given this analysis, a hybrid traction system for suburban trains can be developed using either traditional circuit design principles or innovative medium-frequency converter technology. The first approach relies on proven, reliable technical solutions suitable for current rolling stock. The second promises reduced mass, smaller installation volume, and higher energy efficiency, though practical validation of reliability and cost-efficiency remains necessary.

Let us consider possible variants of traction circuit arrangements using the traditional approach to traction system design, as well as configurations employing converters with a medium-frequency transformer.

Fig. 3 shows the schematic diagram of a hybrid traction system constructed on the basis of traditional design principles.

When operating from the AC traction network, switch $QF1$ and contactors $K1$, $K2$ and $K3$ are closed, while $QF2$ and contactors $K1$ and $K4$ remain open. Power is supplied via the traction transformer T , whose secondary windings feed semiconductor converters $A1$ and $A2$ through additional reactors L . Converters $A1$ and $A2$ operate according to 4QS converter algorithms, which ensure DC-link voltage stabilisation and maintain a near-zero phase shift between current and voltage. The outputs of $A1$ and $A2$ are connected in parallel, and a double-frequency filter F is used to suppress harmonics.

When operating from the DC traction network, switch $QF2$ and contactors $K1$ and $K4$ are closed, while $QF1$ and contactors $K2$ and $K3$ are open. Each of the capacitors C in the voltage divider is connected to converters $A1$ and $A2$, effectively halving the input voltage of each converter compared with the contact network voltage. Reactors $L1$ and $L2$ are connected to the converter outputs to smooth current pulsations, and their outputs are paralleled - forming a four-phase pulse-width modulation converter.

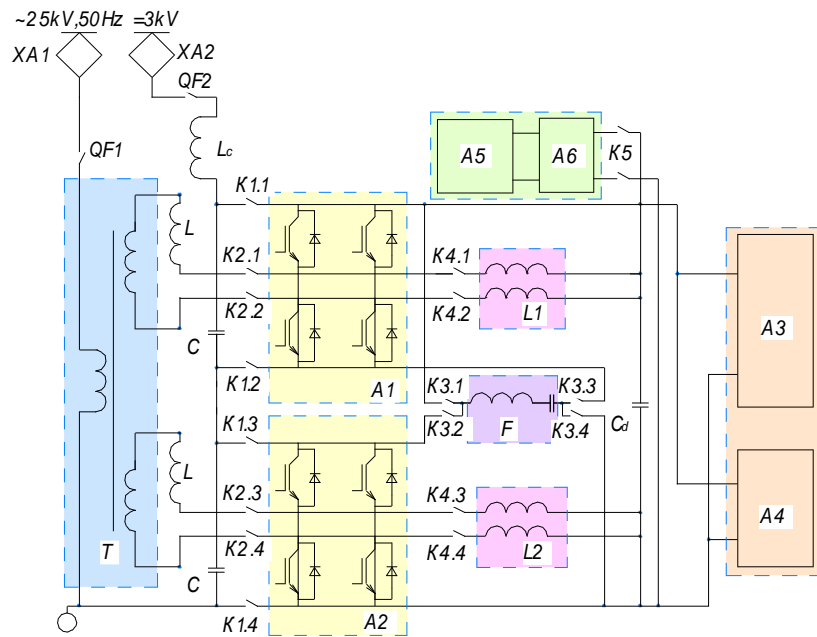

Fig. 3. Schematic diagram of a hybrid traction system for a dual-supply electric train

$XA1$, $XA2$ – pantographs for AC and DC supply respectively; $QF1$, $QF2$ – protection devices; L_c – input choke; T – traction transformer; L – transformer reactor; C – capacitors of the voltage divider; $A1$, $A2$ – input semiconductor converters; F – double-frequency filter; $L1$, $L2$ – output chokes; $K1...K4$ – main circuit contactors; $K5$ – switch of the energy storage system; $A3$ – traction inverter block; $A4$ – auxiliary converters; $A5$ – energy storage system; $A6$ – matching converter; C_d – DC-link capacitor

A line choke L_c limits current ripples drawn from the DC network.

In both supply modes, the energy storage system (comprising the storage unit $A5$ and matching converter $A6$) is connected to the intermediate circuit via switch $K5$. The traction inverters block $A3$ powers and controls asynchronous traction motors, while $A4$ supplies auxiliary systems.

From the above description, it follows that under DC operation, each converter receives half the contact voltage, varying between 1.1 and 2.0 kV. Since the converters are of the step-down type, the DC-link voltage does not exceed 1.1 kV, ensuring its stabilisation despite fluctuations in the contact network. With a DC-link voltage of 900–1000 V, 17-class IGBTs can be used in the traction converter.

Fig. 4 shows a variant of the hybrid traction system employing a medium-frequency converter based on a three-cascade configuration.

When supplied from the AC traction network, $QF1$ is closed, $QF2$ and contactor K are open. The first-stage converters $A1$ of each module operate according to 4QS algorithms, stabilising the voltage on capacitor C . Converters $A2$, $A3$, and the transformer MF reduce the voltage to the required level for traction drive operation. The energy storage system ($A6$ and $A7$) is connected to the intermediate DC link that also powers the traction inverter block $A4$ and auxiliary converters $A5$.

When supplied from the DC network, $QF1$ is open while $QF2$ and K are closed, connecting the capacitors C of all modules directly to the contact network. Thereafter, the operation proceeds identically to the AC mode described above.

To reduce the number of transistors, 65-class IGBTs are used in the first-stage converters. With 12 series-connected modules, the voltage across capacitors reaches 3.4 kV; considering that the contact network voltage may reach 4.0 kV, 65-class IGBTs are also required in the second cascade. Alternatively, the second cascade may use a modular converter design [40]. The traction drive DC-link voltage can be selected within 900–1000 V, which allows the use of 17-class transistors in the traction inverter.

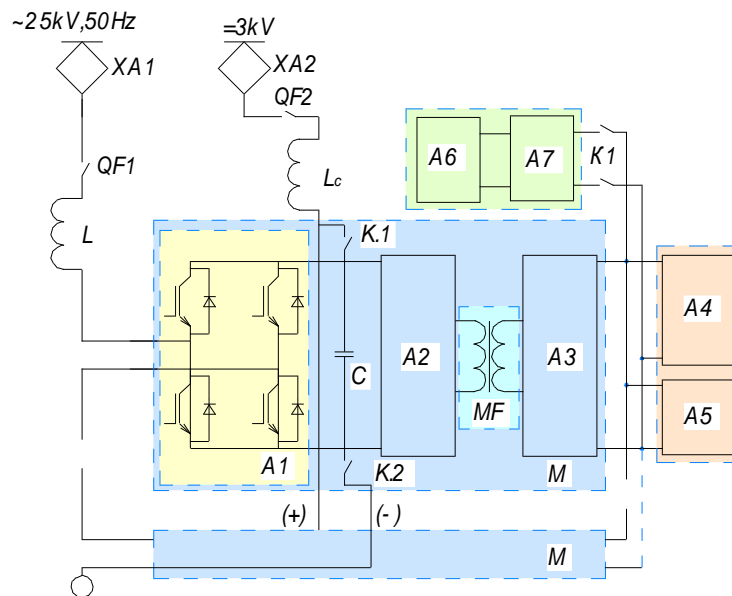

Fig. 4. Schematic diagram of a hybrid traction system with a medium-frequency converter for a dual-supply electric train

XA1, XA2 – pantographs for AC and DC supply respectively; *QF1, QF2* – protection devices; *L_c* – input choke; *L* – additional choke; *C* – input capacitor; *A1* – first-stage converter; *A2* – second-stage converter; *A3* – third-stage converter; *MF* – medium-frequency transformer; *M* – converter module with medium-frequency transformer; *K* – main circuit contactor; *K1* – switch of the energy storage system; *A4* – traction inverter block; *A5* – auxiliary converters; *A6* – energy storage system; *A7* – matching converter.

Energy storage and matching converters are generally designed for DC-link voltages not exceeding 1000 V. Thus, adopting an intermediate voltage below 1000 V enables the use of standardised, proven industrial components.

Thus, the use of both traction system configurations considered in this study is technically feasible. At present, the scheme based on traditional design approaches demonstrates high energy performance. These configurations employ equipment whose manufacturing quality is well established, which ensures high operational reliability of such systems when used in electric rolling stock. The configuration employing converters with a medium-frequency transformer is an innovative solution that requires further research and practical validation under operational conditions. In addition, a comprehensive techno-economic assessment is necessary, as well as an evaluation of its impact on the performance characteristics of electric rolling stock. In view of these considerations, the traditional approach remains the priority for the development of a hybrid traction system for a suburban electric train at the current stage. This approach enables the creation of a hybrid traction system with high reliability indicators.

Conclusions. The study proposes hybrid traction systems for a dual-supply suburban electric train. A comprehensive analysis of modern traction system design approaches was conducted, forming the basis for the proposed concepts.

The first variant - based on traditional circuit design - ensures high reliability through the use of time-tested solutions. The second - an innovative configuration employing medium-frequency transformers - offers potential advantages in reduced weight, smaller equipment volume, and increased energy efficiency. However, due to insufficient data regarding their technical and economic characteristics, the traditional design approach remains preferable.

It has been demonstrated that selecting an intermediate DC-link voltage not exceeding 1000 V expands the range of compatible commercial components for onboard energy storage systems and converters.

REFERENCES

1. Borsuk, Yu.V. (2025) Suburban railway transportation in Ukraine: features of territorial organization and development trends [in Ukrainian]. [Electronic resource]. Access mode: https://geography.lnu.edu.ua/wp-content/uploads/2025/09/Borsuk_Prymiski-zaliznychni-perevezennia-v-Ukraini_2025.pdf.
2. Ukrzaliznytsia (2025). Suburban train schedule. [in Ukrainian]. [Electronic resource]. Access mode: https://uz.gov.ua/passengers/suburban_train_schedule/.
3. Private Joint-Stock Company "Kyiv Electric Wagon Repair Plant" (2025). [in Ukrainian]. [Electronic resource]. Access mode: <https://kevrz.com.ua/index.php/ua/>.
4. Chyhrinov, V. (2024). Retrospective analysis of suburban passenger transportation indicators of the regional branch of JSC «Ukrzaliznytsya». *Sustainable economic development*. 3(50), 458-467. [in Ukrainian] <https://doi.org/10.32782/2308-1988/2024-50-69>.
5. Lomotko, D. V., Krasnoshtan, O. M., Kava, O. S. (2022). Ways to restore the logistics of suburban passenger rail transportation on non-electrified sections of the railway. *Information and control systems in railway transport*, 4, P.41-47. [in Ukrainian].
6. Sablin, O. I., Kuznetsov, V. G., Artemchuk V. V. (2013). Problems and prospects of effective use of electricity recovery in the electric transport system. *Optical-electronic information and energy technologies*, 2, P. 126-130. [in Ukrainian].
7. Buriakovskiy, S. H., Overianova, L. V., Neshcheret, V. O., Ivanov, K. I. (2023). Assessment of the energy saving potential when using energy recovery in a railcar electric rolling stock for suburban transportation. *Bulletin of the National Technical University "KhPI". Series: Energy and heat engineering processes and equipment*, 3(15), 52-59 <https://doi.org/10.20998/2078-774X.2023.03.08>. [in Ukrainian].
8. N. A. Kostyn, A. V. Nykytenko. (2014). Autonomy of recuperative braking is the basis of reliable and energy-efficient recuperation on electromotive components of direct current. *Railway transport of Ukraine*, 3, P. 15–22. [in Ukrainian].
9. Shylo, S. I. (2025). Increasing the efficiency of traction transmission of direct current electric trains: author's abstract of dissertation ... candidate of technical sciences: 05.22.09. Dnipro, 26 p. [in Ukrainian].
10. Zabarylo D. O. (2015). Increasing the efficiency of dual-supply electric rolling stock with asynchronous traction drive: author's abstract of thesis ... candidate of technical sciences: 05.22.09. Dnipropetrovsk. 25 p. [in Ukrainian].
11. Demydov O. V. (2021). Energy-efficient gearless traction drive of a suburban electric train based on a synchronous motor with permanent magnets: author's abstract of the dissertation ... candidate of technical sciences: special. 05.22.09 Kharkiv, 21 p. [in Ukrainian].
12. Mukha, A. M. (2011). Development of scientific foundations for the creation of traction power transmissions of multi-system electric locomotives [Text]: dissertation ... Dr. Tech. Sciences: 05.22.09. Dnipropetrovsk National University of Railway Transport named after V. Lazaryan, - 362 pages. [in Ukrainian].
13. Hulak S. O. (2020). Increasing the energy performance of AC electric locomotives due to reactive power compensation adapted to the power supply system: dissertation ... candidate of technical sciences: special 05.22.09:– Kharkiv, 209 p. [in Ukrainian].
14. Krasnov O. O. (2020). Active traction converter for AC electric locomotives with collector traction motors: dis. ... candidate of technical sciences : 05.22.09 : Kharkiv, 188 p. [in Ukrainian].
15. Overianova, L.V. (2014). Determination of parameters and assessment of properties of electromechanical inertial energy storage devices for suburban electric trains: author's abstract of the dissertation of candidate of technical sciences: 05.22.09, Kharkiv, 20 p. [in Ukrainian].
16. Sulym, A.O. (2023). Increasing the efficiency of electricity use for regenerative braking of metro trains by introducing on-board capacitive energy storage devices [Text]: monograph. *State Property Fund of Ukraine, State Enterprise "Ukr. Research Institute of Carriage Building" (SE "UkrNDIV")*. Kremenchuk: SE "UkrNDIV", 104 p. [in Ukrainian].
17. Kondratieva L. Yu. (2025). Energy-efficient control of the traction electric drive of a quarry locomotive with a combined power plant: dissertation ... doctor of philosophy : special. 141, Kharkiv, 193 s. [in Ukrainian].
18. Yatsko, S., Vashchenko, Ya., Sydorenko, A. (2019). Development of strategies for reducing traction energy consumption by electric rolling stock. *JCPPEE*, Volume 9, Number 1, pp. 44-51 <https://doi.org/10.23939/jcpee2019.01.044>.
19. Maslii, A., Buriakovskiy, S., Antonenko, R., Gevrasov, V., Maslii, A. (2025). Assessing the applicability of energy storage system for plug-in hybrid traction system in rail rolling stock. *Eastern-European Journal of Enterprise Technologies*, 4(1 (136)), 22–31. <https://doi.org/10.15587/1729-4061.2025.337731>.
20. Afanasov, A. M., Lynyk, D. I., Arpul, S. V., Bilukhin, D. S., Vasyliiev, V. Ye. (2022). Prospects for the use of autonomous electric trains with on-board energy storage. *Transport systems and transportation technologies*, (23), S.46-51. <https://doi.org/10.15802/tstt2022/261652>.
21. Steiner, M., Klohr, M., Pagiela, S. (2007). Energy storage system with ultracaps on board of railway vehicles. *2007 European Conference on Power Electronics and Applications*, Aalborg, Denmark, pp. 1-10, <https://doi.org/10.1109/EPE.2007.4417400>.

22. Kono, Y., Shiraki, N., Yokoyama, H., Furuta, R. (2014). Catenary and storage battery hybrid system for electric railcar series EV-E301. *2014 International Power Electronics Conference (IPEC-Hiroshima 2014 - ECCE ASIA)*, Hiroshima, Japan, 2014, pp. 2120-2125, <https://doi.org/10.1109/IPEC.2014.6869881>.
23. Ogasa, M. (2010), Application of Energy Storage Technologies for Electric Railway Vehicles—Examples with Hybrid Electric Railway Vehicles. *IEEJ Trans Elec Electron Eng*, 5: 304-311. <https://doi.org/10.1002/tee.20534>.
24. Yoshiaki, TAGUCHI, Satoshi KADOWAKI, Takayuki NAKAMURA, Masaki MIKI, Kenji HATAKEDA, Yoshimasa ARITA. (2015). Development of a Traction Circuit for Battery-powered and AC-fed Dual Source EMU and Running Test Evaluation of the On-board Battery Performance, *Quarterly Report of RTRI*, Volume 56, Issue 2, Pages 98-104, Released on J-STAGE June 09, 2015, <https://doi.org/10.2219/rtriqr.56.98>, [Electronic resource]. Access mode: https://www.jstage.jst.go.jp/article/rtriqr/56/2/56_98/article/-char/en.
25. Bombardier Talent 3 Battery Train (2025) [Electronic resource]. Access mode: <https://www.railway-technology.com/projects/bombardier-talent-3-battery-train/?cf-view&cf-closed>.
26. FLIRT Akku: continues where the overhead line ends (2025) [Electronic resource]. Access mode: <https://www.stadlerail.com/en/solutions/rolling-stock/mainline-flirt-akku>.
27. Hybrid Multiple Units (2025) [Electronic resource]. Access mode: <https://assets.new.siemens.com/siemens/assets/api/uuid:0a451202-2be4-485d-a736-974d74263e63/siemens-mobility-mireo-plus-b-mireo-plus-h-en.pdf>.
28. Becker, F., Dämmig, A. (2016). Catenary free operation of light rail vehicles — Topology and operational concept. *18th European Conference on Power Electronics and Applications (EPE'16 ECCE Europe)*, Karlsruhe, Germany, pp. 1-10, <https://doi.org/10.1109/EPE.2016.7695286>.
29. Battery Powered Trains (2025) [Electronic resource]. Access mode: <https://www.hitachirail.com/products-and-solutions/rolling-stock/battery-powered-trains/>.
30. Karkosiński, D., Stromski, P., Karkosińska Brzozowska, N. (2021). Hybrid energy storage for electric multiple units to operate at the partially electrified line Gdynia-Hel. *Rail Vehicles. Pojazdy Szynowe*, (1), 18–32. <https://doi.org/10.53502/RAIL-138488>.
31. Steimel, A. (2008). Electric traction - motive power and energy supply : basics and practical experience. Access mode: <https://www.iqytechnicalcollege.com/Electric%20Traction%20-%20Motion%20Power%20and%20Energy%20Supply%20Basics%20and%20Practical%20Experience.pdf>.
32. Eckel, H.-G., Bakran, M. M., Krafft, E. U., Nagel, A. (2005). A new family of modular IGBT converters for traction applications. *2005 European Conference on Power Electronics and Applications*, Dresden, Germany, P.10, <https://doi.org/10.1109/EPE.2005.219248>.
33. Plakhtii, O., Nerubatskyi, V., Sushko, D., Ryshchenko, I., Tsybulnyk, V., & Hordiienko, D. (2019). Improving energy characteristics of ac electric rolling stock by using the three-level active four-quadrant rectifiers. *Eastern-European Journal of Enterprise Technologies*, 4(8 (100)), 6–14. <https://doi.org/10.15587/1729-4061.2019.174112>.
34. Bakran M. M., Eckel, H.-G., Eckert, P., Gambach, H., Wenkemann, U. Comparison of multisystem traction converters for high-power locomotives. *2004 IEEE 35th Annual Power Electronics Specialists Conference*, Aachen, Germany, 2004, pp. 697-703 Vol.1, <https://doi.org/10.1109/PESC.2004.1355833>.
35. Farnesi, S., Marchesoni, M., Passalacqua, M., Vaccaro, L. (2019). Solid-State Transformers in Locomotives Fed through AC Lines: A Review and Future Developments. *Energies*, 12(24), 4711. <https://doi.org/10.3390/en12244711>
36. BORDLINE® M400_DC_3000V_M For Hybrid Bi-Mode Locomotives (2025) [Electronic resource]. Access mode: https://library.e.abb.com/public/5f0dd4e9c23c4f19842ac96a34a85872/BORDLINE%20M400_DC_3000V_M.pdf.
37. Dong-Uk Kim, Jin-Hyuk Park, Seung-Hwan Lee, Sungmin Kim (2025). Development of medium voltage single-phase solid-state transformer for high-speed railway vehicles: reduced scale verification results. *High Voltage*, 10(3), 555–569 (2025). <https://doi.org/10.1049/hve2.70061>.
38. Morel, F., Stackler, C., Ladoux, P., Fouineau, A., Wallart, F., Evans, N., Dworakowski, P. (2019). Power electronic traction transformers in 25 kV / 50 Hz systems: Optimisation of DC/DC Isolated Converters with 3.3 kV SiC MOSFETs. *PCIM Europe 2019; International Exhibition and Conference for Power Electronics, Intelligent Motion, Renewable Energy and Energy Management*, Nuremberg, Germany, 2019, pp. 1-8.
39. E. S. Lee, J. H. Park, M. Y. Kim, J. S. Lee. (2022). High-Efficiency Module Design of Solid-State Transformers for Railway Vehicles, *IEEE Transactions on Transportation Electrification*, vol. 8, no. 1, pp. 98-120, <https://doi.org/10.1109/TTE.2021.3101733>.
40. Adamowicz, M., Szewczyk, J. (2020). SiC-Based Power Electronic Traction Transformer (PETT) for 3 kV DC Rail Traction. *Energies*, 13(21), 5573. <https://doi.org/10.3390/en13215573>.

Євген Рябов¹, Лілія Овер'янова², Костянтин Іванов⁴, Ірина Білоконь⁴, Антон Жуков⁵

¹Доцент, Кафедра електричного транспорту та тепловозобудування, Національний технічний університет «Харківський політехнічний інститут», вул. Кирпичова, 2, м. Харків, 61002, Україна. ORCID: <https://orcid.org/0000-0003-0753-514X>.

²Доцент, Кафедра електричного транспорту та тепловозобудування, Національний технічний університет «Харківський політехнічний інститут», вул. Кирпичова, 2, м. Харків, 61002, Україна
ORCID: <https://orcid.org/0000-0002-4827-572X>.

³Аспірант, Кафедра електричного транспорту та тепловозобудування, Національний технічний університет «Харківський політехнічний інститут», вул. Кирпичова, 2, м. Харків, 61002, Україна
ORCID: <https://orcid.org/0009-0000-3000-8191>.

⁴Директор, Кременчуцький фаховий коледж транспортної інфраструктури та технологій, вул. Юрія Руфа, 14, м. Кременчук, Полтавська область, 39600, Україна.
ORCID: <https://orcid.org/0000-0002-4675-3994>.

⁵ТОВ «Харківський електро-машинобудівний завод», пр. Героїв Харкова, 199, Харків, 61037, Україна
ORCID: <https://orcid.org/0009-0001-5229-1685>.

Розробка гібридної тягової системи для приміського електропоїзду з двосистемним живленням

***Анотація.** У статті розглянуто та проаналізовано варіанти побудови тягових систем сучасного електрорухомого складу. Розглянуто та проаналізовано тягові системи, в яких використовуються традиційні підходи до схемотехнічних рішень. Проведено огляд тягових систем з перетворювачами з середньочастотними трансформаторами, використання яких зменшує масу електрообладнання, потребує меншого простору для його розміщення та підвищує енергоефективність електрорухомого складу. Показано, що пріоритетним є використання гібридної тягової системи з традиційною схемотехнікою, обладнання для якої має високі показники надійності. Запропоновано варіанти гібридних тягових систем для приміського електропоїзду з двосистемним живленням. Показано доцільність стабілізації напруги проміжного контуру для забезпечення автономності енергообміну між системою накопичення енергії та тяговим електроприводом. Проведено опис роботи схем та показано, що при виборі напруги проміжної ланки не вище 1000 В можливе використання серійних технічних рішень в обладнанні системи накопичення енергії. Запропоновані гібридні тягові системи можуть бути використанні при модернізації чи створенні моторвагонного електрорухомого складу, а також бути використанні на іншому рейковому транспорті.*

Ключові слова: електрорухомий склад, енергоефективність, гібридна тягова система, тяговий електропривод, накопичувач енергії, тяговий перетворювач, тяговий трансформатор, тяговий асинхронний електродвигун.

Дата першого надходження статті до видання 20.09.2025

Дата прийняття до друку статті 17.11.2025