

# TRANSPORT SYSTEMS AND TECHNOLOGIES



Issue 46



2025

**МІНІСТЕРСТВО ОСВІТИ І НАУКИ УКРАЇНИ  
НАЦІОНАЛЬНИЙ ТРАНСПОРТНИЙ УНІВЕРСИТЕТ**

**ТРАНСПОРТНІ СИСТЕМИ  
І ТЕХНОЛОГІЇ**

**ВИПУСК 46**

**Видається з 1998 року**

**Київ•2025**

Transport Systems and Technologies. № 45. Kyiv: NTU, 2025. 208 p. DOI:10.32703/2617-9059-2025-46

e-ISSN 2617-9059

p-ISSN 2617-9040

Збірник містить статті, присвячені теоретичним, методологічним і прикладним проблемам транспортної галузі. У статтях збірника розглядаються питання транспортної інфраструктури та рухомого складу, технології та організації транспортних процесів, інформаційних та комп'ютерних технологій на транспорті, математичного моделювання об'єктів транспорту, екологічної безпеки на транспорті.

Для науковців, викладачів, студентів вищих навчальних закладів і працівників транспорту та зв'язку.

#### Редакційна колегія:

**О.М. Горобченко**, доктор технічних наук, професор, професор кафедри «Електромеханіка та рухомий склад залізниць» (головний редактор);

**В.М. Твердомед**, кандидат технічних наук, доцент, директор Навчально-наукового Київського інституту залізничного транспорту, НТУ;

**О.В. Фомін**, доктор технічних наук, професор, професор кафедри «Вагони та вагонне господарство», НТУ;

**Н.С. Брайковська**, кандидат технічних наук, професор, професор кафедри «Вагони та вагонне господарство», НТУ;

**Е.І. Даниленко**, доктор технічних наук, професор, професор кафедри «Залізнична колія та колійне господарство», НТУ, академік Транспортної академії України, лауреат Державної премії України в галузі науки і техніки, Заслужений діяч науки і техніки України;

**О.І. Стасюк**, доктор технічних наук, професор, професор кафедри «Автоматизація та комп'ютерно-інтегровані технології транспорту», НТУ, член-кореспондент Транспортної академії України, лауреат Державної премії України в галузі науки і техніки;

**В.К. Мироненко**, доктор технічних наук, професор, завідувач кафедри «Управління комерційною діяльністю залізниць», НТУ, академік ТАУ, академік Міжнародної академії життєдіяльності;

**В.П. Ткаченко**, доктор технічних наук, професор, завідувач кафедри «Електромеханіка та рухомий склад залізниць», НТУ;

**Л.І. Тимченко**, доктор технічних наук, професор, завідувач кафедри «Системи штучного інтелекту та телекомунікаційні технології», НТУ;

**В.М. Самсонкін**, доктор технічних наук, професор, професор кафедри «Управління процесами перевезень», НТУ;

**С.Ю. Сапронова**, доктор технічних наук, професор, професор кафедри «Вагони та вагонне господарство», НТУ;

**Г.І. Кириченко**, доктор технічних наук, професор, професор кафедри «Технології транспорту та управління процесами перевезень»;

**В.В. Косарчук**, доктор технічних наук, професор, завідувач кафедри «Теоретична та прикладна механіка», НТУ;

**О.Г. Стрелко**, доктор історичних наук, професор, заступник директора Навчально-наукового Київського інституту залізничного транспорту, НТУ;

**О.А. Герцій**, кандидат технічних наук, доцент, доцент кафедри «Автоматизація та комп'ютерно-інтегровані технології транспорту», НТУ;

**С.А. Ісасенко**, кандидат педагогічних наук, доцент, доцент кафедри «Іноземні мови», НТУ;

**І.В. Грицук**, доктор технічних наук, професор, професор кафедри експлуатації суднових енергетичних установок, Херсонська державна морська академія;

**Б.Г. Любарський**, доктор технічних наук, професор, завідувач кафедри «Електричний транспорт і тепловозобудування» НТУ «Харківський політехнічний інститут»;

**А.П. Фалендиш**, доктор технічних наук, професор, завідувач кафедри «Транспортні технології підприємств» Приазовського державного технічного університету;

**В. О. Карацук**, кандидат технічних наук, доцент кафедри рухомого складу транспортних систем ДВНЗ «Приазовський державний технічний університет»;

**В.І. Мацюк**, доктор технічних наук, професор, професор кафедри «Торговельне підприємництво та логістика» Київського національного торговельно-економічного університету;

**А.В. Прохорченко**, доктор технічних наук, професор, професор кафедри «Управління експлуатаційною роботою» Українського державного університету залізничного транспорту;

**В.Г. Пузир**, доктор технічних наук, професор, завідувач кафедри «Експлуатація та ремонт рухомого складу» Українського державного університету залізничного транспорту;

**М. Менг**, доктор філософії, викладач машинобудування (інженерія, обчислювальна техніка та математика), Плімутський університет (Велика Британія);

**С. Мечніковський (S. Mieszniowski)**, Dr. hab., Prof., кафедра ринку транспортних послуг, Гданський університет (Польща);

**С. Андонова (S. Andonova)**, Assos. Prof. Eng., PhD, декан інженерного факультету Південно-Західний університет "Неофіт Рилски" (Болгарія);

**Ю. Герліці (J. Gerlici)**, Prof., Dr. Ing., завідувач кафедри транспорту та підйомно-транспортних машин Жилінського університету (Словацька Республіка);

**В. Хаусер (V. Hauser)**, Ing., PhD, науковий співробітник кафедри транспорту та підйомно-транспортних машин Жилінського університету (Словацька Республіка);

**Я. Діжо (J. Dižo)**, Ing., PhD, доцент кафедри транспорту та підйомно-транспортних машин Жилінського університету (Словацька Республіка);

**Р. Кершус (R. Keršus)**, PhD, Assoc. Prof., кафедра транспортної інженерії, Каунаський технологічний університет (Литва);

**В. Пиштек (Václav Pištěk)** Prof., Dr. Sc. Techn., Brno University of Technology, Technická, Brno (Чехія);

**П. Кучера (Pavel Kučera)** Assoc. Prof., PhD, Brno University of Technology, Technická, Brno (Чехія);

**Г.М. Голуб**, кандидат технічних наук, доцент, завідувачка кафедри «Автоматизація та комп'ютерно-інтегровані технології транспорту», НТУ (технічний секретар);

**С.О. Гулак**, кандидат технічних наук, доцент, доцент кафедри «Електромеханіка та рухомий склад залізниць», НТУ (технічний секретар).

*Журнал включено до міжнародних наукометричних баз даних та електронних бібліотек: DOAJ (Directory of Open Access Journals), MIAR (Information Matrix for the Analysis of Journals), ICI World of Journals (Index Copernicus), Scilit, ResearchBib, BASE (Bielefeld Academic Search Engine), ROAD (Directory of Open Access scholarly Resources), OpenAIRE (Open Access Infrastructure for Research in Europe), Crossref, Worldcat, EuroPub, Наукова періодика України, Google Scholar.*

Статті збірника проходять обов'язкове подвійне сліпе рецензування членами редакційної колегії та залученими рецензентами, друкуються мовою оригіналу. Редакція не обов'язково поділяє думку автора і не відповідає за фактичні помилки, яких він припустився.

Рекомендовано до друку Вченою радою Національного транспортного університету (протокол № 12 від 27 листопада 2025 р.).

Видавець – Національний транспортний університет  
Ідентифікатор медіа - R30-05246

Збірник внесено до Переліку наукових фахових видань України,  
в яких можуть публікуватися результати дисертаційних робіт на здобуття наукових ступенів доктора та кандидата наук у технічній галузі  
(Додаток 11 до наказу Міністерства освіти і науки України 29.12.2014 № 1528)  
та відноситься до категорії "Б" (відповідно до Порядку формування Переліку наукових фахових видань України, затвердженого наказом МОН України від 15 січня 2018 року № 32) періодичних фахових видань України.

<https://tst.duit.in.ua/>

© Національний транспортний університет, 2025

**MINISTRY OF EDUCATION AND SCIENCE OF UKRAINE  
NATIONAL TRANSPORT UNIVERSITY**

**TRANSPORT SYSTEMS AND TECHNOLOGIES**

**ISSUE 46**

**Published from the year 1998**

**Kyiv·2025**

Transport Systems and Technologies. № 46. Kyiv: NTU, 2025. 208 p. DOI:10.32703/2617-9059-2025-46

e-ISSN 2617-9059

p-ISSN 2617-9040

The collection contains articles devoted to theoretical, methodological and applied problems of the transport industry. The articles of the collection consider the issues of transport infrastructure and rolling stock, technology and organization of transport processes, information and computer technologies in transport, mathematical modeling of transport facilities, environmental safety in transport.

For researchers, teachers, students of higher educational institutions and transport and communications workers.

#### Editorial board:

**O. Gorobchenko**, Doctor of Technical Sciences, Professor, Professor of the department "Electromechanics and rolling stock of railways", (Editor-in-Chief);

**V. Tverdomed**, PhD in Technical Sciences, Assoc. Prof., Director of the Kyiv Institute of Railway Transport NTU;

**O. Fomin**, Doctor of Technical Sciences, Prof., Professor of the Department "Railway Carriages and Carriage Facilities";

**N. Braikovska**, PhD in Technical Sciences, Professor, Professor of the Department "Railway Carriages and Carriage Facilities";

**E. Danilenko**, Doctor of Technical Sciences, Prof., Head of the department "Railway Track and Track Facilities", Academician of the Transport Academy of Ukraine, Laureate of the State Prize of Ukraine in the field of science and technology, Honored Worker of Science and Technology of Ukraine;

**O. Stasiuk**, Doctor of Technical Sciences, Prof., Professor of the department "Automation and Computer Integrated Transport Technologies", corresponding member of the Transport Academy of Ukraine, Laureate of the State Prize of Ukraine in the field of science and technology;

**V. Myronenko**, Doctor of Technical Sciences, Prof., Head of the department "Management of Commercial Activities of Railways", Academician of the Transport Academy of Ukraine, Academician of the International Academy of Vital Activity;

**V. Tkachenko**, Doctor of Technical Sciences, Prof., Head of the department "Electromechanics and rolling stock of railways";

**L. Tymchenko**, Doctor of Technical Sciences, Prof., Head of the department "Artificial intelligence systems and telecommunication technologies";

**V. Samsonkin**, Doctor of Technical Sciences, Prof., Professor of the department "Management of transport processes";

**S. Sapronova**, Doctor of Technical Sciences, Prof., Professor of the department "Railway Carriages and Carriage Facilities";

**H. Kyrychenko**, Doctor of Technical Sciences, Prof., Professor of the department "Transport technologies and Management of transport processes";

**V. Kosarchuk**, Doctor of Technical Sciences, Prof., Head of the department "Theoretical and Applied Mechanics";

**O. Strelko**, Doctor of Historical Sciences, Professor, Dean of the Faculty of Railway Transport Management;

**O. Hertsii**, PhD in Technical Sciences, Assoc. Prof., Head of the department "Automation and Computer Integrated Transport Technologies";

**S. Isaienko**, PhD in Pedagogical Sciences, Assoc. Prof., Associate Professor of the Department of Foreign Languages;

**I. Gritsuk**, Doctor of Technical Sciences, Professor, Professor of the Department of Ship Power Plants Operation, Kherson State Maritime Academy

**B. Liubarskyi**, Doctor of Technical Sciences, Prof., Head of the department "Electric transport and diesel locomotive construction" NTU "Kharkov Polytechnic Institute";

**A. Falendysh**, Doctor of Technical Sciences, Prof., Head of the department "Transport technologies of enterprises" Priazovskiy State Technical University;

**V. Karashchuk**, PhD in Technical Sciences, Assoc. Prof. of the department of rolling stock of transport systems, "Priazov State Technical University";

**V. Matsiuk**, Doctor of Technical Sciences, Professor, Professor of the Department of Trade Entrepreneurship and Logistics, Kyiv National University of Trade and Economics;

**A. Prokhorchenko**, Doctor of Technical Sciences, Assoc. Prof., Professor of the department "Management of Operational Work" of the Ukrainian State University of Railway Transport;

**V. Puzyr**, Doctor of Technical Sciences, Prof., Head of the department "Maintenance and repair of rolling stock" of the Ukrainian State University of Railway Transport;

**M. Meng**, PhD, Lecturer in Mechanical Engineering (Engineering, Computing and Mathematics), University of Plymouth, (United Kingdom);

**S. Miecznikowski**, Dr. hab., Prof., Department of Transport Services Market, University of Gdańsk, (Poland);

**S. Andonova**, Prof., Dr. Eng., Head of the department "Mechanical Engineering and Technologies", South-West University "Neofit Rilski" (Bulgaria);

**J. Gerlici**, Prof., Dr. Ing., Head of the Department of Transport and Handling Machines, University of Zilina (Slovak Republic);

**V. Hauser**, Ing., PhD, Researcher of the Department of Transport and Handling Machines, University of Zilina (Slovak Republic);

**J. Dižo**, Ing., PhD, Associate Professor of the Department of Transport and Handling Machines, University of Zilina (Slovak Republic);

**R. Keršys**, PhD, Assoc. Prof., Associate Professor of the Department "Transport Engineering", Kaunas University of Technology (Lithuania);

**V. Pištěk**, Prof., Dr. Sc. Techn., Brno University of Technology, Technická, Brno (Czech Republic);

**P. Kučera**, Assoc. Prof., PhD, Brno University of Technology, Technická, Brno (Czech Republic);

**H. Holub**, PhD in Technical Sciences, Associate Professor of department "Automation and Computer Integrated Transport Technologies" (technical secretary);

**S. Goolak**, PhD in Technical Sciences, Associate Professor of the department "Electromechanics and rolling stock of railways" (technical secretary).

*Journal is included in the international scientific databases: DOAJ (Directory of Open Access Journals), MIAR (Information Matrix for the Analysis of Journals), ICI World of Journals (Index Copernicus), Scilit, ResearchBib, BASE (Bielefeld Academic Search Engine), ROAD (Directory of Open Access scholarly Resources), OpenAIRE (Open Access Infrastructure for Research in Europe), Crossref, Worldcat, EuroPub, Наукова періодика України, Google Scholar.*

The articles of the collection undergo mandatory double blind peer review by members of the editorial board and invited reviewers, and are printed in the original language. The editorial board does not necessarily share the author's opinion and is not responsible for the factual errors that he made.

Recommended for publication by the Academic Council of National Transport University (Minutes № 12 of November 27, 2025).

Publisher – National Transport University  
Media ID is R30-05246

The journal is included in the List of Scientific and Professional Publications of Ukraine, in which the results of dissertations for obtaining the scientific degrees of doctor and candidate of sciences in the technical field can be published (Appendix 11 to the order of the Ministry of Education and Science of Ukraine dated 29.12.2014 No. 1528) and belongs to the "B" category (in accordance with the Procedure for the formation of the List of scientific specialized publications of Ukraine, approved by the order of the Ministry of Education and Science of Ukraine dated January 15, 2018 No. 32) of periodic specialized publications of Ukraine.

<https://tst.duit.in.ua/>

© National Transport University, 2025

UDC 656.2

**Vadym Liashenko<sup>1\*</sup>, Serhii Yatsko<sup>2</sup>**

<sup>1</sup>Postgraduate student, Department of Electrical Power Engineering, Electrical Engineering and Electromechanics, Ukrainian State University of Railway Transport, Oboronnyi Val Sq, 7, Kharkiv, 61001, Ukraine. ORCID: <https://orcid.org/0009-0005-1139-3537>.

<sup>2</sup>Associate Professor, Department of Electrical Power Engineering, Electrical Engineering and Electromechanics, Ukrainian State University of Railway Transport, Oboronnyi Val Sq, 7, Kharkiv, 61001, Ukraine. ORCID: <https://orcid.org/0000-0002-5977-8613>.

\*Corresponding author: [lyashenkovm99@gmail.com](mailto:lyashenkovm99@gmail.com).

### **Study of influence of imprecision of primary information on energy consumption of rolling stock**

*The energy efficiency of urban rail transportation systems is a crucial indicator, as traction energy consumption typically accounts for 40-60% of the total energy consumption of the transportation system. This study examines the sensitivity of energy consumption to deviations from nominal conditions under the implementation of pre-calculated optimized trajectories for electric rolling stock, considering rolling stock with operation modes typical for suburban and urban transport. To determine globally optimal control strategies that minimize energy consumption while complying with operational constraints, the study uses dynamic programming based on Bellman's optimality principle. The optimization model divides the track section into discrete segments and uses the backward induction method to establish optimal control laws, producing speed trajectories as functions of the train's current coordinates on a given gradient profile. The trade-off between energy and time is represented by an indefinite Lagrange multiplier to ensure adherence to the timetable. Sensitivity analysis is performed by simulating inaccuracies in the estimates of the train's current coordinates and variations in its passenger load. Modelling of a targeted braking system has been implemented so as to ensure stopping accuracy in the event of measurement inaccuracies. Modelling was performed using three typical gradient profiles, characteristic primarily of underground railways; for comparison, modelling was also performed on a conditional section with a negligible gradient. The research methodology allows for a quantitative assessment of the degree of energy overconsumption that may be caused by deviations in train passenger load factors and errors in the estimation of the position of rolling stock ( $\pm 25$  meters), which provides information for assessing the effectiveness of pre-calculated optimized trajectories in real operating conditions.*

**Keywords:** *speed trajectory optimization, urban rail transport, energy efficiency, dynamic programming.*

**Introduction.** The reduction of energy consumption for a given traffic schedule is one of the most important priorities for urban rail transport systems. Electricity costs typically account for a significant portion of transport companies' operating costs, with traction energy accounting for approximately 40-60% of total energy consumption in such systems.

Speed trajectory optimization is one of the viable approaches for minimizing energy consumption through determining the optimal control strategy that minimizes power requirements. It relies on a systematic search for the most energy-efficient combinations of traction, coasting and braking phases, while satisfying schedule and safety constraints [1].

Dynamic programming, based on Bolman's optimality principle [2], is one of the most effective methods for optimizing speed trajectories due to its ability to guarantee convergence to a global minimum (within the margin of error of discretization). This method evaluates all possible control sequences by breaking down the optimization problem into a series of sequential recursive decision-making steps, ensuring that the solution represents a truly optimal policy rather than a local minimum [3]. This mathematical basis provides a theoretical guarantee of optimality.

However, the dynamic programming approach requires a backward calculation of trajectories, starting from the final conditions and moving towards the initial state, which complicates real-time updates and requires preliminary calculations for each section of track under consideration [4]. In general, optimal trajectories must be calculated in advance for specific operating scenarios and saved for subsequent implementation by automated train control systems. Dependence on pre-calculated solutions becomes particularly problematic when considering that optimal trajectories are significantly affected by changes in train mass, since in modern metro rolling stock, passenger load can account for up to 40% of the total mass of the consist. These changes in weight directly affect the dynamic characteristics of the train and energy consumption.

**The purpose and tasks of research.** The main goal of this study is to quantitatively assess the sensitivity of energy consumption when operating on optimized trajectories, but with deviations from the calculated conditions. Although existing optimization methods can generate globally optimal control strategies for specific scenarios, real-world driving conditions always involve a certain degree of uncertainty. The study aims to analyze the gap between theoretical optimizations and the practical application of calculated trajectories.

The study covers several interrelated tasks. First, to develop an algorithm for optimizing the train's trajectory under given route conditions, rolling stock characteristics and operational constraints. Second, to develop a model of rolling stock dynamics that allows for deviations of train characteristics from the calculated ones, while maintaining the optimized motion trajectory. Third, to conduct a systematic sensitivity analysis on different track profiles representing different operational complexities and to quantitatively assess energy overconsumption caused by load variations and spatial positioning errors within  $\pm 25$  meters. Through this comprehensive approach, the study aims to provide a practical understanding of the reliability of pre-calculated optimal trajectories and to provide insights for decision makers on acceptable limits for operational tolerances that maintain energy efficiency benefits under real-world operating conditions in urban rail transport.

**Analysis of recent research and problem statement.** Numerous publications are devoted to the problem of electricity consumption in rail transport, particularly in the metro, and its optimization. General systematic approaches and reviews of energy-efficient control methods are presented in [5-7]. The main ways to reduce electricity consumption are to optimize the movement trajectory and/or optimize schedules. Research in this area covers the application of various mathematical methods, such as: Pontryagin's maximum principle [8-12], dynamic programming [1, 3-4, 13-16], as well as evolutionary, heuristic, intelligent and other optimization algorithms [17-22].

A separate group of works focuses on increasing the stability (robustness) of optimal trajectories to the influence of unpredictable factors, such as uncertainty of passenger load or changes in external conditions [26-27].

At the same time, despite significant achievements, the number of works devoted to the quantitative study of the impact of individual factors on the electricity consumption of rolling stock, in particular in the context of implementing pre-calculated optimal trajectories in conditions that deviate from the calculated ones, has been limited.

**Research materials and methods.** Trajectory optimisation for any vehicle is the process of finding the relationship between the vehicle's speed  $v$  and its coordinates  $s$  or time  $t$  that minimises (or maximises) a specific target value. As a rule, the task of speed trajectory optimisation is to find a trajectory  $v(s)$  or  $v(t)$  that would minimise the total energy consumption  $A$  for the movement of vehicle. Formally, in general, the task of optimization of the speed trajectory can be represented as:

$$\min_{v(\cdot)} \int_0^t A(v(t)) dt : t \leq T_3, \quad v(t) \leq v_{max}, \quad \dots, \quad (1)$$

where  $A(v(t))$  is the energy consumption depending on speed trajectory  $v(t)$ , kWh;

$v(t)$  – speed trajectory as function of time, m/s;

$t$  – time, s;

$T_t$  – target time on route (scheduled), s;

$v_{max}$  – maximum speed limited by traffic requirements or design speed of rolling stock, m/s.

To solve the optimization problem using dynamic programming, the continuous state  $x$  is divided into a discrete sequence. Let  $J_i(x)$  be the minimum ‘cost’ from step  $i$  to the end of the grid, for state  $x$ , then the Bellman equation

$$J_i(x) = \min_u \{l_i(x, u) + J_{i+1}(f_i(x, u))\}, \quad (2)$$

where  $l_i$  is a cost of singular step and  $f_i$  is a function of change of state given control sequence  $u$ .

In dynamic programming optimization, a transition table  $J(x)$  and optimal control sequence  $u(i)$  is calculated sequentially, moving backwards from the grid end. Resulting control sequence corresponds to a specific speed trajectory  $x(i)$ .

In this study, to optimize train speed trajectory, a given section of track with a length of  $S$  m is split into  $n$  separate independent segments, with train movement considered as a function of distance. The segments act as optimization steps. Each segment has a corresponding value of the gradient  $i$ , ‰. The segment length  $s_n$ , m, (discreteness of the division) is specified in advance before modelling and is selected to be sufficiently small (5-10 m) to reduce its impact on the accuracy of calculations. If a segment contains a gradient break, it is further divided into two smaller segments, thus fully preserving the longitudinal profile of the section.

The model used to optimize the train's trajectory (Figure 1) can be is of a network type [28] with feedback loops and consisting of two main structural components:

- the model of rolling stock dynamics (train movement model) that reflects the impact of control signal  $u(n)$  on train movement, taking into account its load, traction characteristics and gradient conditions;
- the actual control and optimization model responsible for selection of the control signal  $u(n)$  given the outputs of train movement model.

The criterion of optimality is reaching the final destination without exceeding the scheduled travel time for the route  $T_t$ , s, and with minimal total electricity consumption  $A$ , kWh.

The motion of a train is described by the basic equation of train motion

$$\frac{dv}{dt} = \frac{F - B - T}{P} \cdot \frac{g}{(1 + \gamma)}, \quad (3)$$

where  $F$  is tractive effort, kN;

$B$  – brake force, kN;

$W$  – total resistance, kN;

$P$  – train weight, kN;

$g$  – gravitational constant (9,81 m/s<sup>2</sup>),

$\gamma$  – rotating mass inertial coefficient ( $\approx 0,12$ ).

The weight of a train consists of the weight of the rolling stock itself and the weight of passengers

$$P = P_T + 0.7355 \cdot k_f \cdot C, \quad (4)$$

where  $P_T$  is the weight of the rolling stock (tare), kN;  
 0.7355 is average weight of a single passenger, kN (75 kg);  
 $k_f$  is a coefficient of passenger load, 0...1;  
 $C$  is maximum passenger capacity of a given train.

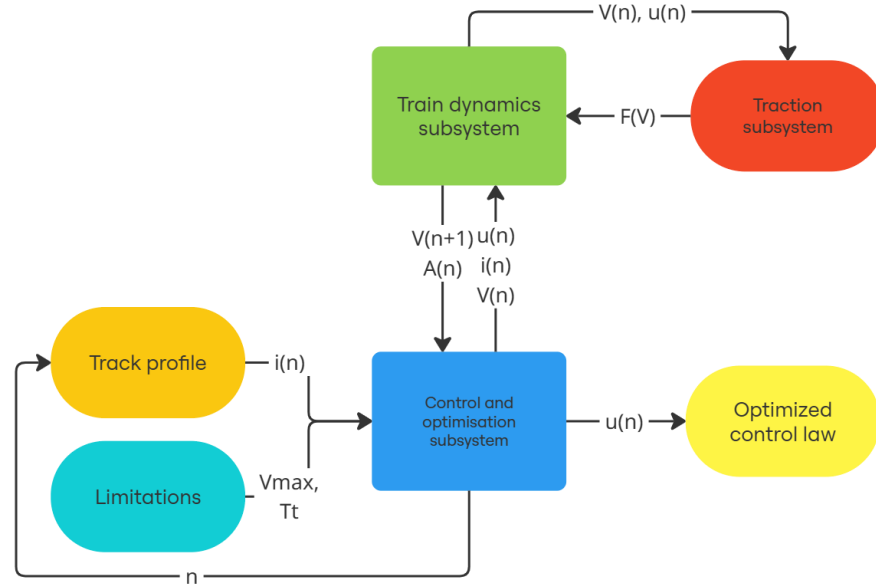

Fig. 1. Structural diagram of the train trajectory optimization model

The system of equations describing the operation of the train traction drive on the  $n$ -th track section is as follows:

$$F_n = \begin{cases} \min[F_{max}, F(V)], & 0 < u \leq 1; \\ 0, & u = 0; \\ B_{max} \cdot u_n, & -1 \leq u < 0, \end{cases} \quad (5)$$

where  $F_n$  is tractive effort at  $n$ -th route section, kN;  
 $F_{max}$  is maximum tractive effort of a motor car subject to current limitation or wheel-rail adhesion, kN;  
 $B_{max}$  is maximum braking force of a motor car subject to current limitation or wheel-rail adhesion, kN (it was conditionally assumed that  $B_{max} = -F_{max}$ );  
 $F(V)$  is traction characteristics of a motor car depending on speed;  $V$  is speed, km/h;  
 $u_n$  is a control signal (we hereinafter also refer to it as *traction application coefficient* for clarity) at  $n$ -th section.

For the purposes of this study, the traction characteristics and rolling stock parameters of the 81-7036/7037 model metro consist manufactured by PJSC ‘Kryukiv Railway Car Building Works’ were used for modelling. The 5-car consist is equipped with an asynchronous traction drive with a traction motor power of 4×180 kW per car.

The electricity consumption for passing any section of the route  $A_n$ , kWh, can be determined as follows during modelling

$$A_n = \begin{cases} \frac{\sum N_n \cdot \Delta t}{3600 \cdot \eta}, & F_n > 0; \\ 0, & F_n \leq 0, \end{cases} \quad (6)$$

where  $N_n$  is total developed power of the train traction drive on the  $n$ -th section ( $N_n = F_n \cdot V_n$ );  $\eta$  is total efficiency of the traction drive (for asynchronous drives  $\eta = 0,8 \dots 0,9$ ; 0,85 was assumed for modelling),  $\Delta t_n$  is time to pass the  $n$ -th section; 3600 is conversion factor from seconds to hours.

With dynamic programming for each section of the route  $n$  all possible transitions between discrete states of the system are calculated. This means that for every possible section entry speed  $V_n$  calculations are performed sequentially for different values of the control signal  $u_n$ , whereby  $u_n \in [-1, 1]$ . For each combination  $(n, V_n, u_n)$  using equations 5 and 3 the resulting speed at the end of the section  $V'_n$  and electricity consumption  $A_n$  are determined. This also allows to determine the time it would take for a train to pass a single section  $t_n$ , s:

$$t_n = \frac{2 \cdot s_n}{\frac{V_n}{3.6} + \frac{V'_n}{3.6}}, \quad (7)$$

where  $s_n$  is a length of  $n$ -th route section, m;

3.6 – conversion factor from kilometres per hour to metres per second. Given the small size of the sections, the acceleration value on them is assumed to be constant.

Complete calculation of all valid combinations  $(n, V_n, u_n)$  allows the use of the recursive Bellman equation, which will include a similar equation for the next section  $n+1$ , i.e. the conditional cost value of passing through all subsequent sections

$$J_n(V_n, u_n) = \min_{-1 \leq u_n \leq 1} \{A_n + \lambda \cdot t_n + J_{n+1}(V'_n)\}, \quad (8)$$

whereby the cost function of a single section  $n$  for control signal  $u_n$  is

$$l_n(V_n, u_n) = A_n + \lambda \cdot t_n, \quad (9)$$

where  $\lambda$  is indeterminate Lagrange multiplier and is determined iteratively.

After passing through all  $n$  sections in reverse order, a table of costs for all possible combinations is generated  $J_n(V_n, u_n)$  by selecting for each section  $n$  such a  $u_n$  which corresponds to lowest cost function value  $J$ , moving backwards from the end state. Thus, an optimal control law for given conditions  $u(s)$  is established.

The target trajectory is calculated for an average case with a passenger load coefficient of  $k_f = 50\%$ . In real conditions, the load coefficient is a volatile value that cannot be measured with high accuracy, so it is important to analyze how its deviation from the calculated value affects energy consumption, provided that the automated train operation system follows the calculated trajectory. Similarly, the current position of the train cannot be measured with perfect accuracy, so there are always certain deviations, which will also affect energy consumption on the route. The sources of error in determining the train's coordinates require further study, and the law of its change as a function of the distance travelled is unknown; therefore, for this study, it was assumed that the coordinate error is a constant value throughout the entire route.

Deviations in train weight and its current coordinates are entered into the motion simulation as follows. When performing traction calculations (acceleration and deceleration values), the 'actual' train weight  $P'$  calculated using equation 4 with arbitrary passenger load coefficient  $k_f$  is used. The train's position  $s$  is substituted with fictitious position coordinate  $s'$

$$s' = s + \Delta s, \quad (10)$$

where  $\Delta s$  is an error of determination of current train position, in meters.

To ensure accurate train stopping at stations with a small enough deviation of the stopping point from the target point, but with a high (and therefore energy-efficient) average deceleration value, a precision braking system has been introduced into the train movement simulation. A schematic diagram of this system is shown in Figure 2.

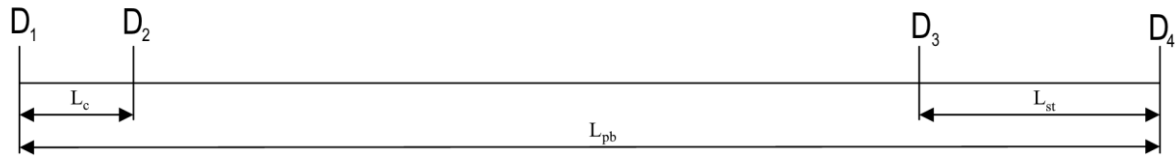

Fig. 2. Layout of the train precision braking system

The system consists of three sensors  $D_1$ ,  $D_2$  and  $D_3$ .  $D_4$  indicates the designated stopping point of the train. The distance from the stopping point at which precision braking is applied is marked as  $L_{pb}$  and was established as 300 meters. When passing the first sensor  $D_1$  the current train coordinate calculated by the onboard systems is reset and set equal to  $S - L_{pb}$  m, i.e. the full length of the route except for the distance of targeted braking. On the segment between the first  $D_1$  and second sensor  $D_2$  a calibration of train coordinate measurements by onboard systems is performed by comparing them with a known distance  $L_c$ . This reduces the dependence of the braking trajectory on measurement errors. At a short distance from the stopping point  $L_{st}$  sensor  $D_3$  again resets the current train coordinate, accepting it as equal to  $S - L_{st}$ . The target speed of the train in the precision braking zone is determined as

$$v(s) = 3.6 \cdot \sqrt{2 \cdot d \cdot (S - s)}, \quad (11)$$

where  $v(s)$  is target train speed at coordinate  $s$ , km/h;

3,6 is conversion factor from m/s to km/h;

$d$  is a target deceleration value during braking,  $m/c^2$  (was established as  $0,6 m/s^2$ );

$S$  is the length of the segment, m;  $s$  is current train coordinate (distance from the starting point), m.

Modelling of such a system has shown that it is resistant to various forms of measurement errors (errors in speed measurement by an axial sensor, deviations in values  $L_{pb}$ ,  $L_c$ ,  $L_{st}$  from calculated) and ensures that the train stops with acceptable deviations from the stopping point [29].

To model train movement, three conditional types of gradient profiles were used: I ('light'), II ('medium') and III ('heavy') developed on the basis of previous research findings [30]. They are presented in Tables 1-3. Additionally, for comparison purposes, calculations were also performed for a gradient profile with a constant gradient of 3‰ and a length of 1000 m ('type 0' gradient profile).

Table 1. Type I conditional gradient profile ('light')

Segment length, m	150	200	200	200	150	100
Gradient, ‰	3	10	-3	3	10	0

Table 2. Type II conditional gradient profile ('medium')

Segment length, m	150	50	150	50	100	250	400	50	100
Gradient, ‰	-5	-30	-30	-3	-3	-3	11	17	0

Table 3. Type III conditional gradient profile ('heavy')

Segment length, m	150	50	200	200	50	100	50	300	400	50	50	100
Gradient, ‰	5	-5	3	5	3	35	11	40	30	17	5	0

Examples of optimised speed trajectories and speed trajectories with measurement errors are shown in Figures 3-6. Solid lines correspond to calculated trajectories; dashed lines correspond to trajectories with errors.

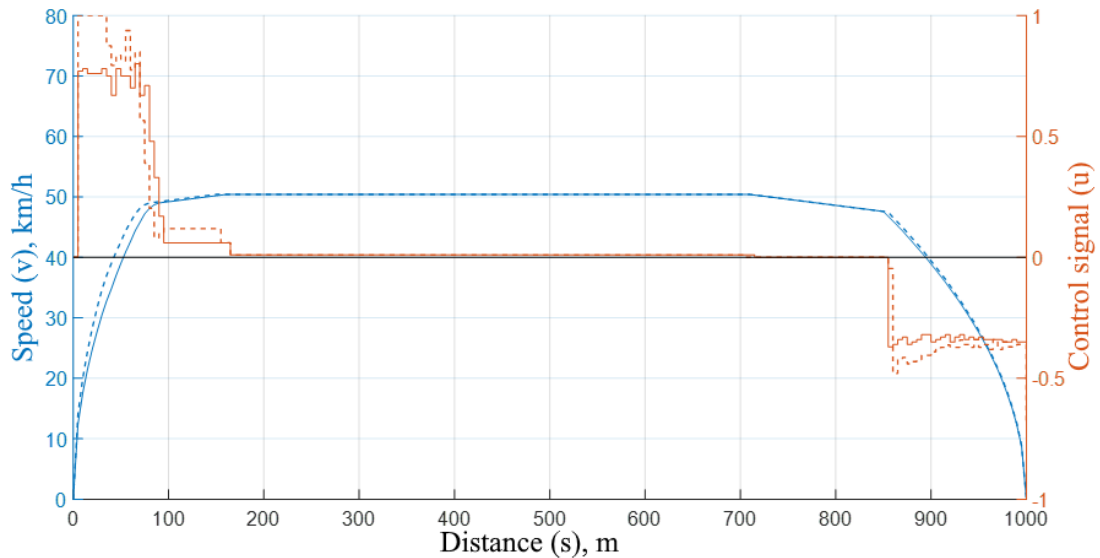

Fig. 3. Example of train speed trajectories on a conditional gradient profile of type 0 [average speed – 40 km/h; actual passenger load coefficient – 1.0; coordinate estimation error – +10 m]

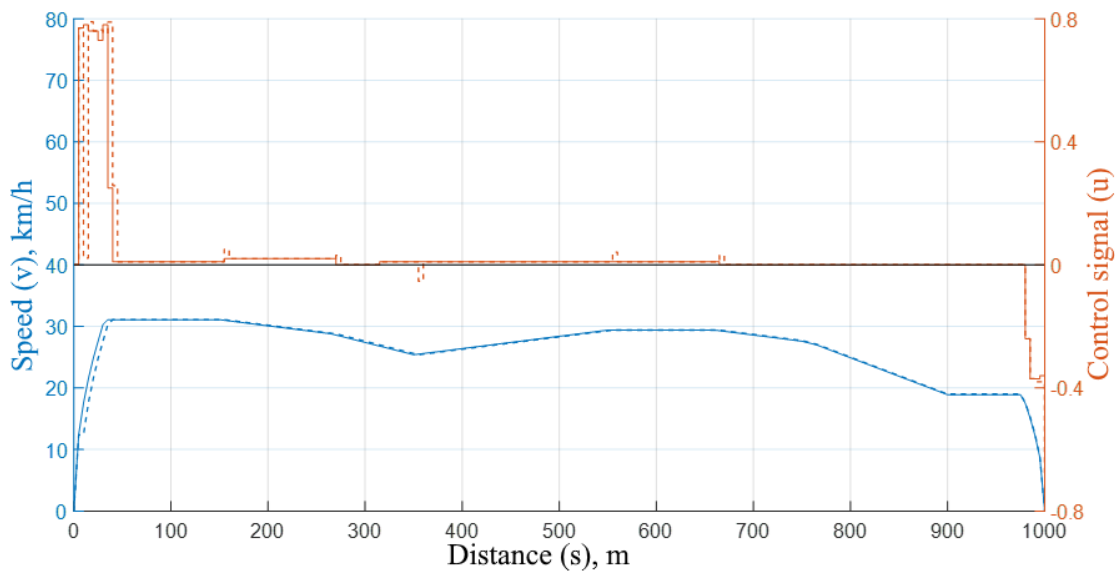
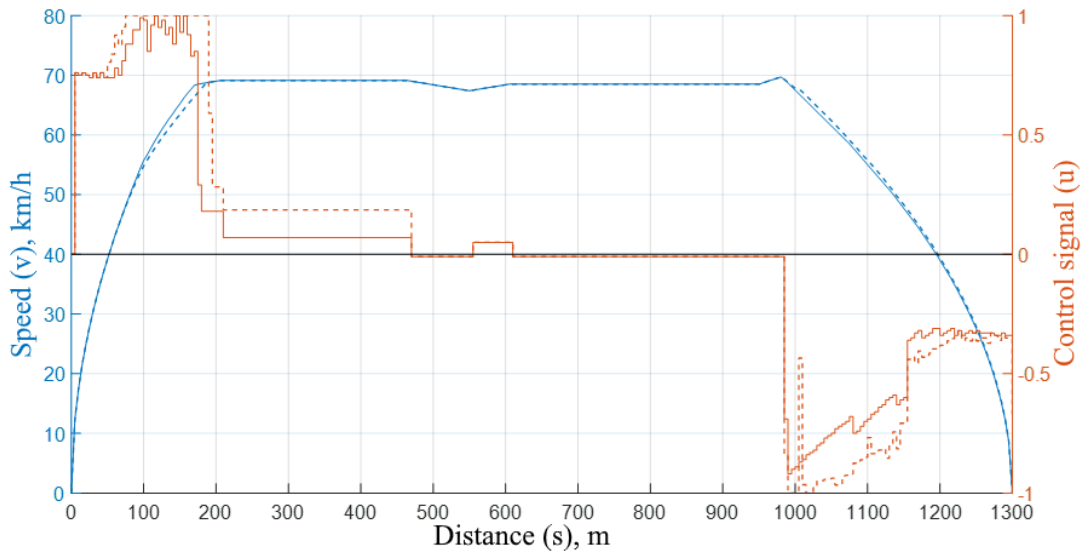
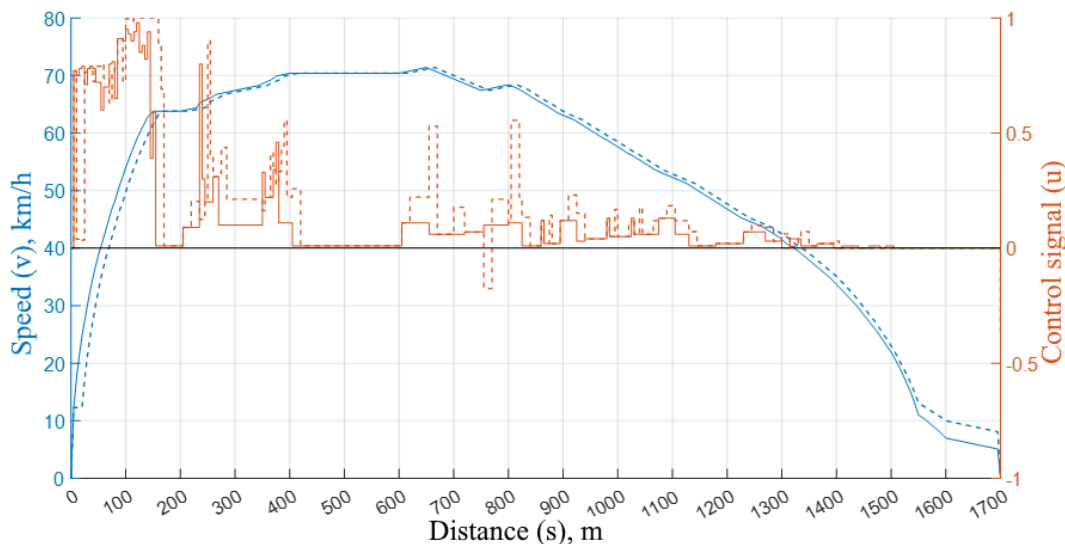

Fig. 4. Example of train speed trajectories on a conditional gradient profile of type I ['light' profile; average speed – 25 km/h; actual passenger load coefficient – 0.2; coordinate estimation error – -5 m]



**Fig. 5. Example of train speed trajectories on a conditional gradient profile of type II [‘medium’ profile; reverse direction; average speed – 50 km/h; actual passenger load coefficient – 1.0; no coordinate estimation error]**



**Fig. 6. Example of train speed trajectories on a conditional gradient profile of type III [‘heavy profile; average speed – 30 km/h; actual passenger load coefficient – 0.8; coordinate estimation error – -15 m]**

Any of the introduced errors in modelling the train's movement along a pre-optimized trajectory leads to an increase in the amount of electricity consumed to cover the route. Sensitivity analysis, in which different error values are entered into the system, allows to determine the impact of each of them on energy overconsumption. To perform the sensitivity analysis, a speed of 35 km/h was taken as the base average speed for the route (typical for metro operation); energy overconsumption  $\epsilon_A$  is calculated relative to it as

$$\epsilon_A = \frac{(A'_f + A'_r) - (A_f + A_r)}{A_f + A_r}, \tag{12}$$

where  $A_f, A_r$  are energy expenditures to cover the route along an optimised trajectory, in the absence of errors, in the forward and reverse directions, respectively;

$A'_f, A'_r$  are energy expenditures to cover the route in the presence of train weight deviations and errors of measured coordinates, likewise in the forward and reverse directions.

Margins for calculation of energy overconsumption  $\varepsilon_A$  were established as follows: passenger load coefficient  $k_f$  from 0 to 1, train coordinate measurement error  $s'$  – from -25 to +25 m. The simulation summaries are presented in Tables 4-7 and Figures 7-10.

**Table 4. Energy overconsumption  $\varepsilon_A$  for ‘type 0’ gradient profile**

Passenger load coeff. \ Coordinate error, m	0	0,25	<b>0,5</b>	0,75	1
25	2,2%	2%	1,9%	2,4%	3,5%
20	1,9%	1,8%	1,6%	2,2%	3,5%
10	2,0%	1,8%	1,7%	2,2%	3,2%
<b>0</b>	0,5%	0,1%	<b>0,0%</b>	0,5%	2,0%
-10	2,2%	2,1%	2,1%	2,3%	3,4%
-20	2,3%	2,2%	2,2%	2,3%	3,7%
-25	2,8%	2,8%	2,8%	2,9%	4,3%

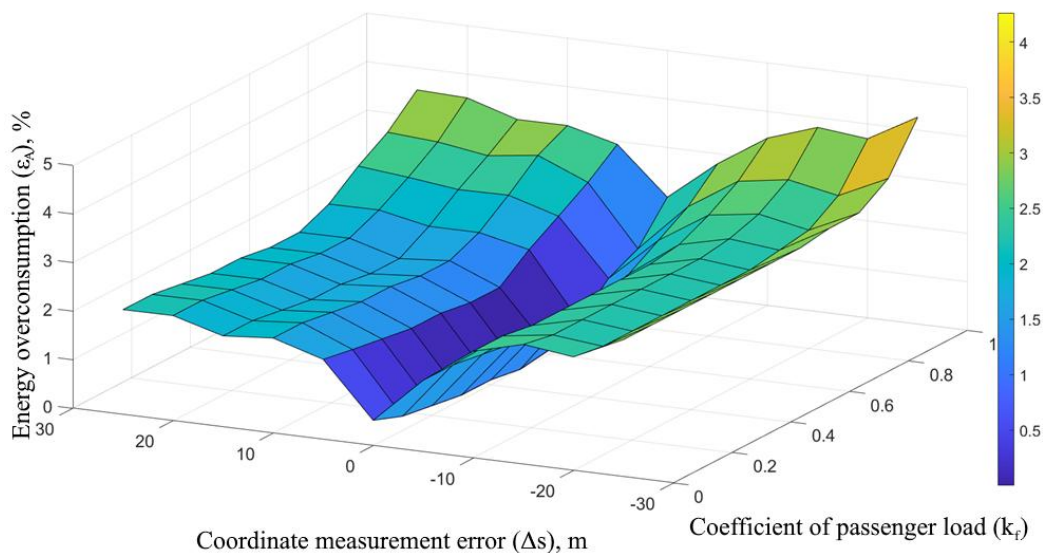

**Fig. 7. Dependency of energy overconsumption  $\varepsilon_A$  on error of measurement of train coordinate and train weight deviations for ‘type 0’ gradient profile**

**Table 5. Energy overconsumption  $\varepsilon_A$  for type I (‘light’) gradient profile**

Passenger load coeff. \ Coordinate error, m	0	0,25	<b>0,5</b>	0,75	1
25	5,9%	5,5%	5,4%	6,2%	8,0%
20	5,2%	4,8%	4,6%	5,5%	7,3%
10	3,3%	2,9%	2,6%	3,4%	5,3%
<b>0</b>	0,4%	0,1%	<b>0,0%</b>	0,9%	2,9%
-10	3,5%	3,3%	3,3%	3,7%	5,7%
-20	4,7%	4,6%	4,6%	5,0%	6,8%
-25	5,6%	5,6%	5,6%	5,9%	7,6%

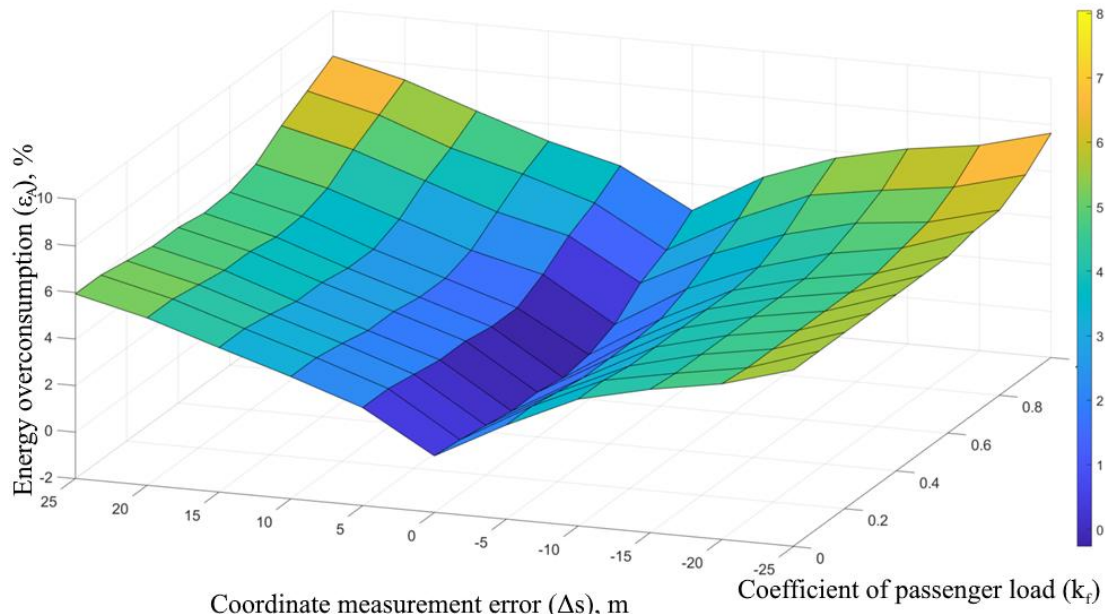

Fig. 8. Dependency of energy overconsumption  $\epsilon_A$  on error of measurement of train coordinate and train weight deviations for type I ('light') gradient profile

Table 6. Energy overconsumption  $\epsilon_A$  for type II ('medium') gradient profile

Passenger load coeff. \ Coordinate error, m	0	0,25	<b>0,5</b>	0,75	1
25	9,9%	10,1%	10,8%	13,7%	15,5%
20	8,3%	8,4%	9,2%	12,3%	14,2%
10	5,1%	5,2%	5,7%	9,7%	11,6%
<b>0</b>	0,2%	0,1%	<b>0,0%</b>	5,6%	8,2%
-10	3,7%	4,0%	4,4%	8,1%	10,4%
-20	5,7%	6,0%	6,6%	9,6%	11,6%
-25	6,8%	7,2%	7,8%	10,4%	12,4%

Table 7. Energy overconsumption  $\epsilon_A$  for type III ('heavy') gradient profile

Passenger load coeff. \ Coordinate error, m	0	0,25	<b>0,5</b>	0,75	1
25	9,6%	13,1%	18,7%	32,0%	35,4%
20	7,3%	10,6%	15,4%	29,8%	33,6%
10	2,4%	5,1%	8,4%	24,5%	29,4%
<b>0</b>	-3,2%	-0,7%	<b>0,0%</b>	18,6%	24,4%
-10	2,7%	4,7%	7,3%	22,4%	27,5%
-20	7,2%	9,4%	12,7%	26,0%	31,2%
-25	9,4%	11,5%	15,1%	28,1%	33,1%

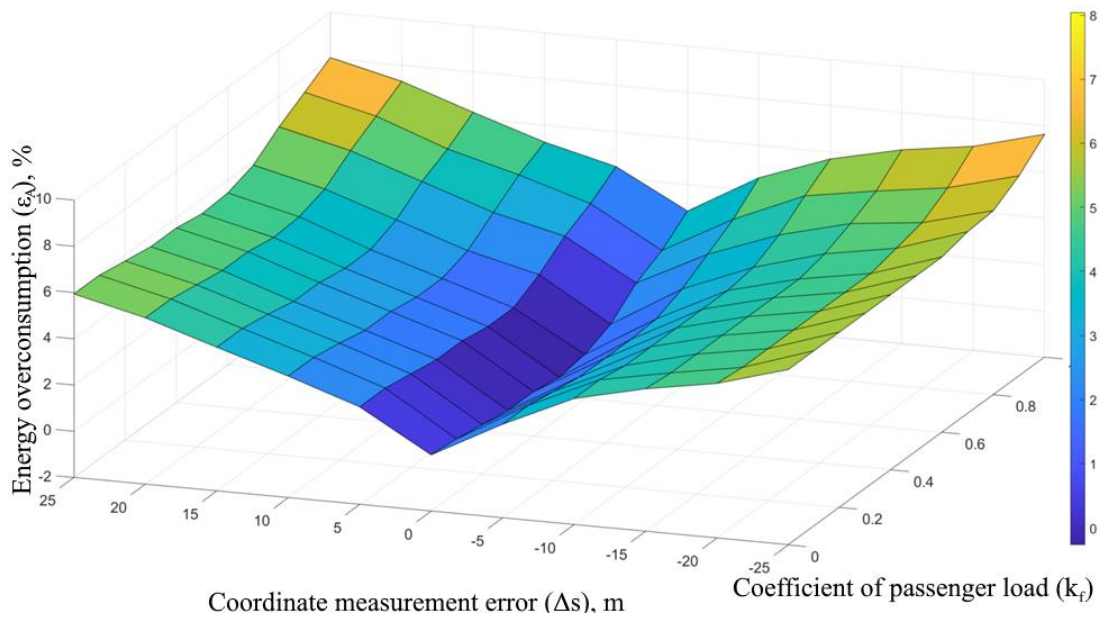

**Fig. 9. Dependency of energy overconsumption  $\epsilon_A$  on error of measurement of train coordinate and train weight deviations for type II ('medium') gradient profile**

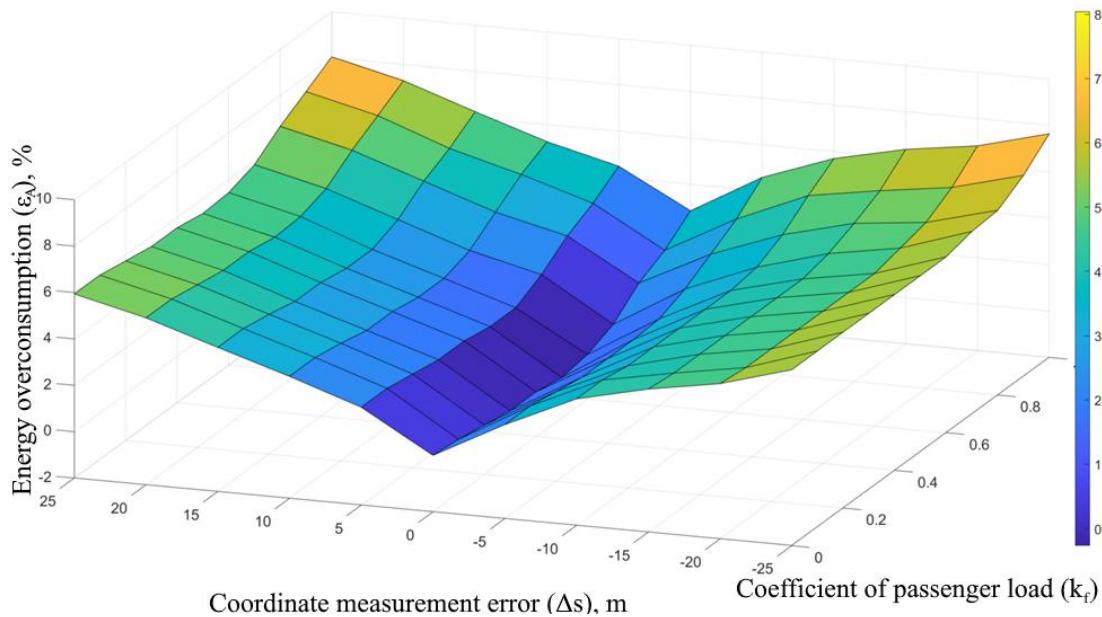

**Fig. 10. Dependency of energy overconsumption  $\epsilon_A$  on error of measurement of train coordinate and train weight deviations for type III ('heavy') gradient profile**

**Conclusions.** In this study, energy consumption was analyzed for train operation along a trajectory optimized for specific conditions with varying degrees of input data reliability (based on train weight and its actual location). The analysis was performed for four typical profiles, varying in length and gradient.

Based on the analysis, the application of the rolling stock trajectory optimization model using dynamic programming by the backward induction method is substantiated. This method allows to obtain a globally optimized control law within the limits of system discreteness. The cost function of each

trajectory option is determined based on the “energy-time” balance using an indefinite Lagrange multiplier, which is refined iteratively using the bisection method.

It has been shown that the speed trajectory optimization model has to be supplemented with a simulation of train dynamics, in which the automatic driving system maintains a given trajectory, with the trajectory being defined as a function of the train coordinate  $V = f(s)$ . The division of trajectories into “optimized” and ‘actual’ allows for deviations of the “actual” parameters from those for which the optimization was performed and allows for the assessment of the impact of deviations on energy consumption, i.e., the sensitivity of energy consumption to deviations from the calculated conditions.

The studies conducted made it possible to assess the degree of influence of the reliability of input information on the increase in electricity consumption and the nature of the influence depending on the profile category. As a rule, energy overconsumption increases with the complexity of the route profile (its length and gradients) – from 4% on the easiest profile to almost 40% on the “difficult” profile. On easy profiles, the greatest impact on overruns is the position measurement error. On heavier profiles, on the contrary, the greatest impact is exerted by the train's passenger load factor.

## REFERENCES

1. Lu, S., Hillmansen, S., Ho, T. K., & Roberts, C. (2013). Single-train trajectory optimization. *IEEE Transactions on Intelligent Transportation Systems*, 14(2), 743-750. <https://doi.org/10.1109/TITS.2012.2234118>.
2. Bellman, R. (1957). *Dynamic programming*. Princeton University Press.
3. Ichikawa, S., & Miyatake, M. (2019). Energy efficient train trajectory in the railway system with moving block signaling scheme. *IEEE Journal of Industry applications*, 8(4), 586-591. <https://doi.org/10.1541/ieejia.8.586>.
4. Ghaviha, N., Bohlin, M., Holmberg, C., Dahlquist, E., Skoglund, R., & Jonasson, D. (2017). A driver advisory system with dynamic losses for passenger electric multiple units. *Transportation Research Part C: Emerging Technologies*, 85, 111–130. <https://doi.org/10.1016/j.trc.2017.09.010>.
5. González-Gil, A., Palacin, R., Batty, P., & Powell, J. P. (2014). A systems approach to reduce urban rail energy consumption. *Energy Conversion and Management*, 80, 509-524. <https://doi.org/10.1016/j.enconman.2014.01.060>.
6. Sanchis, I. V., & Zuriaga, P. S. (2016). An energy-efficient metro speed profiles for energy savings: application to the Valencia metro. *Transportation research procedia*, 18, 226-233. <https://doi.org/10.1016/j.trpro.2016.12.031>.
7. Yang, X., Li, X., Ning, B., & Tang, T. (2015). A survey on energy-efficient train operation for urban rail transit. *IEEE Transactions on Intelligent Transportation Systems*, 17(1), 2-13. <https://doi.org/10.1109/TITS.2015.2447507>.
8. Ichikawa, K. (1968). Application of optimization theory for bounded state variable problems to the operation of train. *Bulletin of JSME*, 11(47), 857–865. <https://doi.org/10.1299/jsme1958.11.857>.
9. Howlett, P. G., & Pudney, P. J. (1995). *Energy-efficient train control*. Springer. <https://doi.org/10.1007/978-1-4471-3084-0>.
10. Khmelnskiy, E. (2000). On an optimal control problem of train operation. *IEEE transactions on automatic control*, 45(7), 1257-1266. <https://doi.org/10.1109/9.867018>.
11. Heineken, W., Richter, M., & Birth-Reichert, T. (2023). Energy-efficient train driving based on optimal control theory. *Energies*, 16(18), 6712. <https://doi.org/10.3390/en16186712>.
12. Tan, Z., Lu, S., Bao, K., Zhang, S., Wu, C., Yang, J., & Xue, F. (2018). Adaptive partial train speed trajectory optimization. *Energies*, 11(12), 3302. <https://doi.org/10.3390/en11123302>.
13. Su, S., Tang, T., Chen, L., & Liu, B. (2015). Energy-efficient train control in urban rail transit systems. *Proceedings of the Institution of Mechanical Engineers, Part F: Journal of Rail and Rapid Transit*, 229(4), 446-454. <https://doi.org/10.1177/0954409713515648>.
14. Huang, Y., Yang, L., Tang, T., Gao, Z., Cao, F., & Li, K. (2018). Train speed profile optimization with on-board energy storage devices: A dynamic programming based approach. *Computers & Industrial Engineering*, 126, 149-164. <https://doi.org/10.1016/j.cie.2018.09.024>.
15. Gao, H., Zhang, Y., & Guo, J. (2020). A novel dynamic programming approach for optimizing driving strategy of subway trains. In *MATEC Web of Conferences* (Vol. 325, p. 01002). EDP Sciences. <https://doi.org/10.1051/mateconf/202032501002>.
16. Byun, Y. S., & Jeong, R. G. (2022). Optimization of driving speed of electric train using dynamic programming based on multi-weighted cost function. *Applied Sciences*, 12(24), 12857. <https://doi.org/10.3390/app122412857>.
17. Wang, P., Trivella, A., Goverde, R. M., & Corman, F. (2020). Train trajectory optimization for improved on-time arrival under parametric uncertainty. *Transportation Research Part C: Emerging Technologies*, 119, 102680. <https://doi.org/10.1016/j.trc.2020.102680>.
18. Zhao, N., Roberts, C., Hillmansen, S., & Nicholson, G. (2015). A multiple train trajectory optimization to minimize energy consumption and delay. *IEEE Transactions on Intelligent Transportation Systems*, 16(5), 2363-2372. <https://doi.org/10.1109/TITS.2014.2388356>.

19. Scheepmaker, G. M., & Goverde, R. M. (2015). The interplay between energy-efficient train control and scheduled running time supplements. *Journal of Rail Transport Planning & Management*, 5(4), 225-239. <https://doi.org/10.1016/j.jrtpm.2015.10.003>.
20. Gupta, S. D., Tobin, J. K., & Pavel, L. (2016). A two-step linear programming model for energy-efficient timetables in metro railway networks. *Transportation Research Part B: Methodological*, 93, 57-74. <https://doi.org/10.1016/j.trb.2016.07.003>.
21. Ye, H., & Liu, R. (2016). A multiphase optimal control method for multi-train control and scheduling on railway lines. *Transportation Research Part B: Methodological*, 93, 377-393. <https://doi.org/10.1016/j.trb.2016.08.002>.
22. Wang, P., & Goverde, R. M. P. (2019). Multi-train trajectory optimization for energy-efficient timetabling. *European Journal of Operational Research*, 272(2), 621-635. <https://doi.org/10.1016/j.ejor.2018.06.034>.
23. Liu, H., Zhou, M., Guo, X., Zhang, Z., Ning, B., & Tang, T. (2018). Timetable optimization for regenerative energy utilization in subway systems. *IEEE Transactions on Intelligent Transportation Systems*, 20(9), 3247-3257. <https://doi.org/10.1109/TITS.2018.2873145>.
24. Brenna, M., Foiadelli, F., & Longo, M. (2016). Application of genetic algorithms for driverless subway train energy optimization. *International Journal of Vehicular Technology*, 2016(1), 8073523. <https://doi.org/10.1155/2016/8073523>.
25. Fernández-Rodríguez, A., Cucala, A. P., & Fernández-Cardador, A. (2020). An eco-driving algorithm for interoperable automatic train operation. *Applied Sciences*, 10(21), 7705. <https://doi.org/10.3390/app10217705>.
26. Trivella, A., Wang, P., & Corman, F. (2021). The impact of wind on energy-efficient train control. *EURO Journal on Transportation and Logistics*, 10, 100013. <https://doi.org/10.1016/j.ejtl.2020.100013>.
27. Chen, X., Li, K., Zhang, L., & Tian, Z. (2022). Robust optimization of energy-saving train trajectories under passenger load uncertainty based on p-NSGA-II. *IEEE Transactions on Transportation Electrification*, 9(1), 1826-1844. <https://doi.org/10.1109/TTE.2022.3194698>.
28. Kustovska O. (2005). *Methodology of Systematic Approach And Scientific Research: Lecture Course*. Ekonomichna Dumka. [in Ukrainian].
29. Liashenko, V., Yatsko, S., & Vaschenko, Y., & Khvorost, M. (2023). Simulation of the system of provision of target braking of rolling stock. *Information and Control Systems on Railway Transport*, 28(2), 63-73. <https://doi.org/10.18664/iksz.v28i2.283285>.
30. Liashenko, V. M., Ustenko, O. V., & Yatsko, S. I. (2025). Study of the power consumption of electric rolling stock operating with repeated short-time traction cycles on different gradients. *Collection of Scientific Works of the Ukrainian State University of Railway Transport*, 211, 63-73. <https://doi.org/10.18664/1994-7852.211.2025.327149>. [in Ukrainian].

**Вадим Ляшенко<sup>1\*</sup>, Сергій Яцько<sup>2</sup>**

<sup>1</sup>Аспірант кафедри електроенергетики, електротехніки та електромеханіки, Український державний університет залізничного транспорту, Майдан Оборонний Вал, 7, Харків, 61001, Україна. ORCID: <https://orcid.org/0009-0005-1139-3537>.

<sup>2</sup>Кандидат технічних наук, доцент кафедри електроенергетики, електротехніки та електромеханіки, Український державний університет залізничного транспорту, Майдан Оборонний Вал, 7, Харків, 61001, Україна. ORCID: <https://orcid.org/0000-0002-5977-8613>.

### **Оцінка впливу неточностей первинної інформації на енергоспоживання рухомого складу**

**Анотація.** Енергоефективність систем міського залізничного транспорту є критично важливим показником, оскільки споживання енергії на тягу зазвичай становить 40-60% від загального енергоспоживання транспортної системи. У цьому дослідженні розглядається чутливість енергоспоживання до відхилень від номінальних умов при реалізації попередньо розрахованих оптимізованих траєкторій руху електрорухомого складу, розглядаючи рухомий склад з режимами роботи, типовими для приміських та міських перевезень. Для визначення глобально оптимальних стратегій керування, які мінімізують споживання енергії при дотриманні експлуатаційних обмежень, в дослідженні використовується динамічне програмування на основі принципу оптимальності Беллмана. Оптимізаційна модель розділяє ділянку колії на дискретні сегменти і використовує метод зворотного проходу для встановлення оптимальних законів управління, створюючи траєкторії швидкості як функції поточних координат поїзда на заданих поздовжніх профілях перегонів. Компроміс між енергією та часом

представлений невизначеним множником Лагранжа для забезпечення дотримання графікового часу руху по перегону. Аналіз чутливості виконується шляхом моделювання неточностей в оцінках поточних координат поїзда та варіацій його пасажирського навантаження. Моделювання системи прицільного гальмування було реалізовано таким чином, щоб забезпечити точність зупинки у випадку неточності вимірювань. Моделювання проводилося з використанням трьох типових профілів перегонів, характерних, в першу чергу, для метрополітенів; для порівняння моделювання також проводилося на умовній ділянці з незначним постійним ухилом. Методика дослідження дозволяє кількісно оцінити ступінь перевитрат енергії, які можуть бути спричинені відхиленнями в завантаженні поїздів пасажирами та похибками в оцінці положення рухомого складу ( $\pm 25$  метрів), що надає інформацію для оцінки ефективності попередньо розрахованих оптимізованих траєкторій в реальних умовах експлуатації.

**Ключові слова:** оптимізація траєкторій руху, міський залізничний транспорт, енергоефективність, динамічне програмування.

*Дата першого надходження статті до видання 28.09.2025*

*Дата прийняття до друку статті 03.11.2025*

UDC 621.313.333:681.518.5:629.423.2

**Olha Babicheva<sup>1</sup>, Viacheslav Shavkun<sup>2\*</sup>, Serhii Yesaulov<sup>3</sup>**

<sup>1</sup>Associate Professor, Department of Electric Transport, O. M. Beketov National University of Urban Economy in Kharkiv, 17 Chornoglazivska St., Kharkiv, 61002, Ukraine. ORCID: <https://orcid.org/0009-0003-1294-2740>.

<sup>2</sup>Associate Professor, Department of Electric Transport, O. M. Beketov National University of Urban Economy in Kharkiv, 17 Chornoglazivska St., Kharkiv, 61002, Ukraine. ORCID: <https://orcid.org/0009-0005-9069-7378>.

<sup>3</sup>Associate Professor, Department of Electric Transport, O. M. Beketov National University of Urban Economy in Kharkiv, 17 Chornoglazivska St., Kharkiv, 61002, Ukraine. ORCID: <https://orcid.org/0009-0006-3274-716X>.

\*Corresponding author: [vm.shavkun@gmail.com](mailto:vm.shavkun@gmail.com).

## **Comprehensive analysis of the sensitivity and criticality of power equipment elements of urban electric transport to operational factors based on structural-functional ranking**

*The article presents a comprehensive reliability analysis of the power equipment of urban electric transport, including traction electric motors, inverters, cable-terminal connections, and cooling systems. Based on a literature review, the strengths (development of non-invasive diagnostic methods, application of machine learning algorithms, and formation of combined maintenance strategies) and weaknesses (limited statistical data for urban fleets, sensitivity of algorithms to noise, insufficient integration with risk management) of current research were identified. A conceptual model of integrated reliability management is proposed, combining multi-source data collection, FMEA-lite methodology, Pareto analysis, and the development of an Action Plan. The analysis results revealed that the highest RPN values are associated with external factors (moisture, overloads) and critical components such as bearings, windings, and cable connections. A Matlab/Simulink model was developed to simulate vibration diagnostics of traction motor bearings, confirming the effectiveness of envelope analysis for early defect detection. The Action Plan implementation reduced average RPN values by 25 – 40%, proving the practical value of the methodology for transport depots. The obtained results provide a foundation for the transition to predictive maintenance and the enhancement of operational reliability in urban electric transport.*

**Keywords:** *urban electric transport; power equipment; reliability; diagnostics; FMEA-lite; Pareto analysis; vibration monitoring; Matlab/Simulink; Action Plan; Predictive Maintenance*

**Introduction and Problem Statement.** The efficiency of urban electric transport operation is largely determined by the operational reliability of its power systems. This complex includes not only traction electric motors (TEMs) but also inverters, converters, cable connections, protective equipment, and cooling systems. It is their combined reliability that determines the level of technical readiness of the rolling stock, the duration of inter-repair intervals, and the safety of passenger transportation.

Under conditions of intensive operation in the urban cycle, power equipment is subjected to dynamic loads, moisture, road vibrations, contamination, and temperature fluctuations. For traction electric motors, this is manifested in bearing wear, degradation of insulation, and brush-commutator unit failures. For inverters and power electronics, it appears as breakdowns of IGBT/MOSFET switches, capacitor aging, and damage to EMI filters. For cable networks and connections, it results in local overheating and corrosion of joints. Insufficient monitoring of these elements leads to emergency shutdowns, increased downtime, and additional maintenance costs.

Current research in the field of urban electric transport diagnostics is mainly focused on individual units, primarily on traction electric motors. Methods of vibration analysis, motor current signature analysis (MCSA), thermal diagnostics, and machine learning algorithms are employed. Their advantage lies in the ability to detect defects at an early stage; however, the limitation is insufficient integration with risk management systems and the maintenance of the entire power equipment complex.

In this context, the application of systemic risk assessment methods becomes relevant, as they enable a comprehensive analysis of both traction drive units and peripheral power subsystems. Among such methods, particular importance is attached to FMEA (Failure Mode and Effects Analysis) and Pareto analysis. The combination of these approaches makes it possible not only to identify critical components and failure factors but also to outline groups of vehicles that account for the largest share of incidents under real operating conditions. This provides the foundation for developing an Action Plan—a targeted program for the maintenance and modernization of the entire power equipment complex of urban electric transport.

**Literature Review.** Current research in the field of urban electric transport reliability is focused on several key directions.

### **1. Diagnostics of traction electric motors (TEM).**

A significant share of studies is devoted to bearing assemblies, which account for the largest proportion of failures. The authors of [1] demonstrated the effectiveness of modern signal processing methods for detecting faults in induction motors; however, the study did not address cable and switching elements, which also affect reliability.

Researchers in [2] confirmed the feasibility of localized analysis of spectral characteristics for different types of machines, though the study is limited to laboratory conditions without considering urban transport operating modes.

In [3], the wavelet transform was applied in combination with ensemble machine learning models, which ensured high accuracy in defect classification, although the algorithms showed sensitivity to noise factors.

Additional studies [4] have shown that deep learning algorithms provide high accuracy in defect classification; however, their effectiveness decreases significantly under noisy conditions and with changes in operating modes, which limits their practical application in transport depots.

The review [5] summarized approaches to early fault detection based on current signals; however, the influence of complex transient modes of real operation was not taken into account.

### **2. Reliability of inverters and power electronics.**

The authors of [6] proposed a unified methodology for structural failure analysis of sensors in PMSM, which directly affects the operation of power converters; however, the emphasis was placed solely on sensors without analyzing key power components.

In [7], failures in electric vehicle drives were systematized, with particular attention given to IGBT modules and capacitors, but the specifics of urban transport were insufficiently addressed.

The researchers in [8] substantiated the feasibility of a hybrid maintenance strategy for inverter systems, although the practical implementation algorithms remain generalized.

The authors of [9] demonstrated that cyclic thermal loading is the main factor in IGBT degradation in traction converters; however, the combined influence of moisture and vibrations was not considered.

In [10], the failure mechanisms of power converters in electric transport were analyzed, but the study was limited to a qualitative description without a quantitative risk model.

### **3. Failures of cable connections and switching equipment.**

Under conditions of moisture and dust, defects in cable lines and terminal connections are common. Domestic researchers emphasize their contribution to overall reliability. In particular, the author of [11] developed methods for monitoring the parameters of traction electric motors, but focused only on motor components. In a subsequent study [12], the same author proposed algorithmic models for reliability assessment, although these have not been integrated into depot practice.

The author of [13] highlighted the importance of selecting an electric motor with consideration of reliability and the condition of cable connections; however, the study did not account for the influence of external operating conditions.

The authors of [14] investigated cable insulation degradation in electric transport, but the study did not address long-term failure statistics in the urban cycle.

#### **4. Cooling and thermal modes.**

In [15], researchers integrated FMEA with sensitivity analysis to evaluate thermal risks, but the study was conducted mainly for railway systems.

In [16], an autoencoder model was applied to detect failures in high-speed trains, yet this approach has not been adapted for urban electric transport.

The authors of [17] summarized the challenges of thermal management in high-power traction systems, but the work is focused primarily on cooling technologies without evaluating economic aspects.

In [18], the researchers integrated FMEA with sensitivity analysis to assess thermal risks; however, the study is limited to railway systems and gives little attention to the specifics of urban transport, as well as to integration with practical risk management systems.

#### **5. System approaches to reliability management.**

The authors of [19] compared the reliability indicators of electric buses in municipal systems, but the study covers only one region and has a limited sample size.

In [20], diagnostic features were used to predict traction motor failures, but the model does not take into account the influence of cooling systems and inverters.

The European standard CENELEC EN 50657:2017 [21] defines requirements for software and reliability control in transport systems, but its implementation in municipal transport of Eastern European countries has not yet been fully realized.

Thus, the strengths of modern studies can be identified as follows:

- the development of non-invasive monitoring methods, in particular MCSA and vibration analysis [1–3];
- the application of machine learning and deep learning algorithms for defect detection and failure prediction [5], [16], [18];
- the formation of combined maintenance strategies that integrate preventive and condition-oriented approaches [7], [8], [10];
- the analysis of operational reliability under urban transport conditions, including the assessment of failure statistics and diagnostic features [11], [12], [19], [20];
- the development of unified methodologies for structural failure analysis in power systems [6];
- the emphasis on the importance of cable connection condition in the reliability of traction electric motors [13];
- the generalization of cooling and thermal management issues in traction systems [17];
- the consideration of international reliability standards in transport systems (EN 50657:2017) [21];
- the application of algorithmic methods for optimizing diagnostics and failure prediction [15].

However, the weaknesses remain as follows:

- limited statistical data on power equipment, specifically in urban electric transport [7], [8], [10];
- sensitivity of algorithms to noise factors and transient modes [3], [4];
- insufficient integration of diagnostics with risk management systems [18];
- underestimation of failures in cable networks and inverters in practical studies [9], [10], [14];
- lack of adaptation of international standards to operating conditions in Eastern Europe [21];
- shortage of comprehensive studies that would take into account the interaction of all subsystems (traction motors, inverters, cables, cooling) within a unified model [6], [17].

#### **Research Aim and Objectives.**

The aim of the study is to improve the reliability and operational efficiency of the power equipment of urban electric transport by integrating the results of FMEA analysis and the Pareto method to develop a targeted Action Plan for maintenance and modernization.

Research objectives:

1. To identify critical units and operational factors that most strongly affect power equipment failures (bearings, windings, terminal–cable connections, inverters, capacitors, cooling systems, power quality, moisture, overloads, thermal cycles).

2. To apply the FMEA-lite methodology to rank possible failures by severity, occurrence, and detectability, calculating an integral risk indicator (FMEA-LITE) for all major components of the power system.

3. To perform a Pareto analysis based on failure statistics in the depot in order to determine groups of rolling stock with the highest number of critical failures.

4. To compare the results of FMEA and Pareto, establishing the relationship between nodal defects and the groups of vehicles in which they most frequently occur.

5. To develop a comprehensive Action Plan – a system of priority measures for maintenance and modernization of power equipment—that ensures a reduction in failure risk and optimization of depot costs.

**Research material.** Within the power equipment of urban electric transport, the most studied and critical element is the traction electric motor (TEM). It accounts for a significant share of failures and determines the operability of the entire electric drive. Therefore, the analysis of the main components and external factors influencing TEM reliability is advisable to perform first.

The reliability of traction electric motors (TEM) in urban electric transport is determined by the condition of their main structural components and the influence of external operational factors. The analysis highlighted several critical elements whose failure most frequently leads to downtime and emergency shutdowns.

The main components of TEM include:

- bearings, which are subjected to high mechanical loads and account for up to 40 % of TEM failures;
- windings and insulation, which degrade under the influence of thermal cycles and moisture, leading to inter-turn short circuits;
- the commutator – brush assembly, prone to sparking and wear, especially under frequent starts;
- terminal–cable connections, which, under the influence of vibrations and corrosion, cause local overheating and sporadic failures;
- the cooling system, the clogging or failure of which causes overheating of all motor components.

Among operational factors, the most significant influence comes from:

- moisture and contamination, which lead to corrosion and a decrease in insulation resistance;
- frequent starts and overloads, typical of the urban driving cycle, which cause overheating and impact loads;
- road vibrations and shocks, which provoke misalignment of assemblies;
- temperature fluctuations, which accelerate the aging of insulation materials.

Thus, the critical factors include both TEM components—bearings, windings, the commutator–brush assembly, cables—and external influences such as moisture, overloads, vibrations, and temperature (see Table 1). These must be taken into account in the FMEA methodology, which allows a quantitative assessment of their contribution to the overall risk of failures.

Thus, a comprehensive assessment of TEM reliability is impossible without considering both the components with the highest probability and severity of failures and the operational factors that accelerate their occurrence.

For a systemic evaluation of the reliability of power equipment in urban electric transport, the article applies a combination of modern diagnostic methods and risk-oriented approaches.

Given that the reliability of the electric drive is determined not only by the condition of individual TEM components but also by the performance of inverters, terminal–cable connections, and the cooling system, it is reasonable to address the task comprehensively. To this end, a conceptual model of integrated reliability management for the power equipment of urban electric transport has been developed, which generalizes all subsystems and ensures the linkage between the stages of diagnostics, risk assessment, and planning of measures.

Based on the results of the literature analysis and the defined objectives, a conceptual model of integrated reliability management of power equipment in urban electric transport has been developed. It encompasses all levels—from data collection and diagnostics to risk assessment and decision-making.

*Table 1. Main components and operational factors affecting the reliability of traction electric motors (TEM) in urban electric transport*

Category	Component / Factor	Typical Failures	Consequences for TEM and the system
<b>TEM components</b>	Bearing assemblies	Raceway wear, clearance, fretting, seizure	Increased vibrations, noise, overheating, emergency shutdown
	Commutator–brush assembly (DC)	Sparking, lamella burning, brush wear	Torque instability, overvoltages, accelerated wear
	Windings and insulation	Inter-turn short circuits, insulation breakdown, local overheating	Torque reduction, emergency shutdown, fire risk
	Squirrel-cage rotor (IM)	Bar cracks, ring detachment	Torque drop, overheating, increased losses
	Cooling system	Fan failure, channel clogging	Overheating of windings and bearings, insulation degradation
	Speed/position sensors	Signal loss, drift, damage	Speed fluctuations, control failures, emergency disconnection
	Terminals and power cables	Loose contacts, corrosion, breaks	Local overheating, “hot spots,” sporadic failures
	Power electronics (inverters, EMI filters)	Switch breakdowns, capacitor degradation, choke saturation	Emergency shutdown, overvoltages, cascading failures
	Mechanical fasteners and couplings	Loosening, misalignment	Increased vibrations, secondary wear of bearings and brushes
<b>Operational factors</b>	Moisture, dust, salt	Condensation, corrosion, insulation resistance reduction	Sparking, insulation degradation, accelerated failures
	Frequent starts and overloads	Overheating, impact loads	Brush and bearing wear, reduced winding life
	Power quality, EMI disturbances	Overvoltages, impulse noise	Emergency shutdowns, heating, reduced lifespan of power electronics
	Road vibrations and shocks	Clearance, cracks, misalignment	Damage to bearings, couplings, brushes
	Thermal cycles, ventilation	Thermal cycling, overheating, channel contamination	Insulation aging, winding overheating
	Maintenance and diagnostics organization	Insufficient periodicity or lack of monitoring	Untimely defect detection, emergency failures

The model is visually presented in Fig. 1, which illustrates the sequence of stages from data collection to the implementation of targeted measures. Such a structure ensures not only fault diagnostics but also effective failure management under real conditions, for example, in a trolleybus depot.

To ensure methodological consistency across all subsystems of the electromechanical drive, a conceptual model of integrated reliability management was developed (Fig. 1). The model combines multi-source data collection (vibration, electrical, thermal, and EMI parameters), diagnostic and anomaly detection algorithms, risk-oriented assessment (including FMEA-LITE calculations and Pareto analysis for the fleet), as well as the formation of an Action Plan (CBM procedures, preventive measures,

modernization, and power quality control). Implementation results are tracked by KPIs (MTBF, failure rate, downtime, FMEA-LITE), providing a closed improvement cycle through feedback.



*Fig. 1. Conceptual model of integrated reliability management of power equipment in urban electric transport, representing the sequence of stages: data sources → diagnostics → risk assessment (FMEA-lite, Pareto) → Action Plan development → KPI monitoring and feedback.*

Thus, the proposed model of integrated reliability management encompasses the most desirable cycle-from multi-source data collection to performance monitoring. At the first level, monitoring is performed for vibration, electrical, thermal parameters, power quality, and operating conditions. The next level provides diagnostics through signal processing algorithms, anomaly detection, thermal monitoring, and expert rules. Risk assessment then follows, using FMEA-lite and Pareto analysis methodologies, allowing quantitative ranking of failures by criticality. Based on these results, an Action Plan is formed, combining condition-based maintenance, preventive and modernization measures, and power quality control. The final stage is performance evaluation through KPIs (MTBF, failure rate, rolling stock downtime, RPN changes), which ensures feedback and a closed reliability improvement cycle.

The presented conceptual model (Fig. 1) defines the general structure of integrated reliability management: from data collection and diagnostics to risk assessment and Action Plan development. For its practical implementation, it is necessary to clearly understand which diagnostic methods can be applied in urban electric transport, their strengths and weaknesses, as well as their impact on FMEA parameters.

In the practice of urban electric transport, the most widely used diagnostic approaches are as follows: vibration diagnostics - used for detecting bearing damage, misalignment, and mechanical defects; its strength lies in high sensitivity to early failures, while its weakness is the need for sensor installation and the complexity of data interpretation in noisy environments; Motor Current Signature Analysis (MCSA) - this current-based method allows non-invasive diagnosis of winding, bearing, and rotor defects; the advantage is the simplicity of data collection, while the drawback is sensitivity to variable loads and transient modes; thermal monitoring (thermography) - enables detection of overheating in windings, cable joints, and insulation, though its effectiveness is limited by the need for specialized equipment and environmental influences; machine learning and deep learning (ML/DL) methods-used to integrate data from multiple channels (vibration, current, temperature), with the strength of high accuracy in classification and prediction, but the weakness of requiring large datasets for model training (see Table 2).

**Table 2. Comparative analysis of modern diagnostic methods and their impact on FMEA parameters**

Method / Approach	Main TEM component	Strengths	Weaknesses	Impact on FMEA parameters
Vibration diagnostics of bearings	Bearings	High sensitivity to defects; early detection	Requires sensors; sensitive to noise	↓ O (Occurrence), ↑ D (Detectability)
MCSA (Motor Current Signature Analysis)	Windings, bearings	Non-invasive; easy to integrate	Influence of network disturbances; domain dependence	↓ O, ↑ D
ML/DL algorithms (ensembles, CNN, transformers)	All components (bearings, windings, gearbox)	Robustness to variable modes; integration of multichannel data	Data-intensive; lack of “traction-specific” datasets	↓ O, ↑ D
Thermography and insulation monitoring	Windings, cables	Detection of overheating and insulation degradation	Requires regulated access; not always online	↓ O, ↑ D
FMEA/FMECA as a methodology	All system components	Ranking of criticality; maintenance planning	Requires failure statistics and expert evaluation	Provides integral FMEA-LITE (S×O×D)

Thus, each of the presented methods has limitations: a shortage of operational data, sensitivity to noise and variable modes, and challenges in implementation within depots. This substantiates the feasibility of applying FMEA (Failure Mode and Effects Analysis), which does not replace but complements existing diagnostic methods by enabling the integration of monitoring results into a quantitative risk model.

Consequently, modern research makes a significant contribution to improving the accuracy of diagnostics of individual TEM components; however, the issues of systematic risk ranking and consideration of operational conditions (moisture, overloads, seasonality) remain unresolved. The FMEA methodology enables combining diagnostic results and practical operational data into a unified risk assessment model, which becomes the basis for developing a priority maintenance plan (Action Plan).

In this regard, it is reasonable to apply the FMEA (Failure Mode and Effects Analysis) methodology, which allows systematic assessment of failure risks, determination of their severity, occurrence probability, and detectability, as well as the establishment of maintenance priorities based on the integral FMEA-lite index. This approach provides not only a scientific rationale for identifying critical components but also practical value for transport enterprises, as it enables the development of an Action Plan to improve reliability and reduce emergency downtime.

The Failure Mode and Effects Analysis (FMEA-lite) method is used for the systematic analysis of potential component failures and the assessment of their impact on system performance. Its application in urban electric transport makes it possible to identify critical traction motor (TEM) components, rank them by risk level, and define priority maintenance measures.

In this study, a systemic approach is applied to reliability assessment of urban electric transport power equipment, combining operational data analysis, the FMEA-lite methodology, and the statistical tool of Pareto analysis. This enables the identification of critical components and the development of a substantiated Action Plan to enhance the efficiency of maintenance.

For comprehensive diagnostics and risk assessment, data from the main subsystems of the electric drive were utilized:

- traction electric motor (TEM): vibration signals, motor current signature analysis (MCSA), thermal regimes of windings and bearings;
- inverter and power electronics: operating parameters of IGBT modules, capacitor ESR, protection signals;
- cable lines and terminal connections: contact resistance, local overheating («hot spots»), thermographic inspection results;
- cooling system: radiator temperature, air or fluid flow rate, condition of fans, ducts, and pumps;
- power quality and EMI: overvoltages, voltage sags, harmonics, electromagnetic disturbances;
- operating environment: humidity level, dust contamination, route profile, frequency of overloads.

For failure risk assessment, a simplified FMEA-lite methodology was applied using three parameters:

- S – Severity: evaluates the criticality of a failure for transport operation and passenger safety;
- O – Occurrence: reflects the frequency of defect manifestation according to operational statistics;
- D – Detectability: characterizes the possibility of timely defect detection.

The evaluation is performed on a scale from 1 to 10:

- S: 1–3 – minor impact; 4–6 – moderate (functional limitations); 7–8 – serious (transport shutdown); 9–10 – critical (safety threat).
- O: 1–2 – isolated cases; 3–5 – 1–5% failures; 6–8 – regular (5–15%); 9–10 – very frequent (>20%).
- D: 1–3 – easily detectable; 4–6 – requires additional measurements; 7–8 – difficult to detect; 9–10 – practically undetectable until failure.

The Risk Priority Number (RPN, FMEA-lite) is determined by the formula:

$$RPN = S \cdot O \cdot D, \quad (1)$$

For the normalization of results, the following rules were applied:

- FMEA-lite > 300 – critical components requiring immediate corrective actions;
- $200 \leq \text{FMEA-lite} \leq 300$  – zone of increased monitoring, requiring regular diagnostics;
- FMEA-lite < 200 – components controlled within the scope of scheduled maintenance.

The summarized results of the assessment are presented in the FMEA-lite table, where for each component the values of S, O, and D are defined, the FMEA-lite index is calculated, and the priority measures are formulated.

The application of FMEA to traction electric motors (TEM) in urban electric transport makes it possible to:

1. identify critical components (bearings, commutator–brush assembly, cable connections, armature windings) whose failures have the greatest impact on trolleybus operation;
2. rank risks and create a priority matrix for planning maintenance and modernization;
3. prevent cascading failures, where a minor fault (e.g., moisture leakage) leads to a chain failure (winding short circuit → inverter failure → vehicle stoppage);
4. build a transition towards Predictive Maintenance, where technical decisions are made based on the monitoring of component condition.

Thus, FMEA becomes the methodological basis for developing a depot Action Plan, enabling reduction of emergency downtime, optimization of costs, and improvement of operational reliability of urban electric transport.

For a comprehensive reliability assessment, FMEA-lite was performed not only for traction electric motors (TEM) but also for the entire set of power equipment in the urban transport drive system: inverters, power switches, capacitors, cable connections, cooling systems, and auxiliary devices.

**Table 3. FMEA-lite for the power equipment of urban electric transport**

Component / Factor	S	O	D	FMEA-LITE	Comment
Moisture and contamination	9	8	6	432	Main cause of TEM insulation degradation and cable connection corrosion [14].
Overloads, frequent starts	9	8	5	360	Lead to TEM overheating, brush and bearing wear [1], [2].
TEM bearings	8	8	5	320	Vibrations and poor-quality lubrication → emergency shutdowns [1], [3].
Commutator–brush assembly	8	7	5	280	Sparking and lamella burning reduce service life by 2–3 times [2].
Armature winding / insulation	9	6	6	324	Overloads + insulation aging → inter-turn short circuits [5].
Terminals and power cables	8	7	6	336	Corrosion and loosened contacts → “hot spots” [13], [14].
Cooling system	8	6	5	240	Channel clogging and fan failures → overheating of components [17].
Inverter IGBT modules	10	5	6	300	High severity of failure (sudden breakdown), medium probability due to thermal cycling [9], [10].
Inverter capacitors	9	6	5	270	Dielectric aging, overheating [10].
EMI filters, chokes	7	5	6	210	Saturation or breakdown causes malfunctions and emergency shutdowns [18].
Mechanical fasteners, couplings	6	5	5	150	Loosening → vibrations and secondary failures [20].

The analysis of the FMEA-lite results (Table 3) confirms that the most critical factors for the reliability of power equipment are external operating conditions and component degradation. In particular, humidity and contamination cause contact corrosion and a reduction of insulation resistance [14], while overloads and frequent starts accelerate the aging of bearings and the commutator–brush assembly [1], [2]. Bearings remain the weak point of TEMs due to vibrations and low-quality lubrication [1], [3], while insulation wear of windings leads to inter-turn short circuits [5]. Cable connections often act as “triggers” of cascading failures due to local overheating [13], [14]. For inverters, the greatest risks are associated with IGBT module breakdowns under thermal cycling [9], [10] and dielectric aging of capacitors [10]. Cooling issues also play a significant role, causing overheating of components [17], along with the influence of electromagnetic disturbances (EMI filters, chokes) [18]. Mechanical fasteners and couplings, although having a lower RPN rating, may also provoke secondary failures [20].

Thus, the FMEA-lite results are consistent with the literature and confirm the necessity of comprehensively accounting for both structural elements and external operational factors when developing a maintenance program.

Although FMEA-lite was applied to all drive subsystems (Table 3), it is most appropriate to examine in greater detail the results for traction electric motors, which account for the largest share of failures in urban transport. **Figure 2 presents a diagram of the TOP-5 critical directions for TEMs based on data from the Kharkiv depot.**

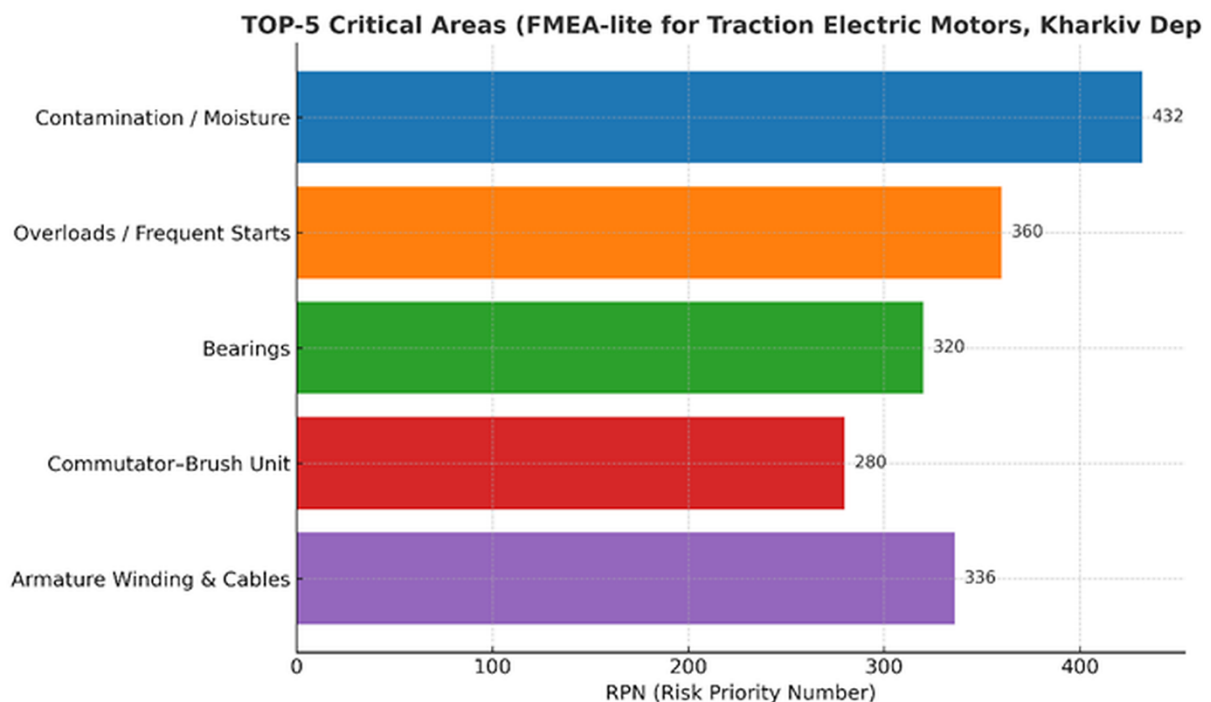

**Fig. 2. Results of FMEA-lite analysis for traction electric motors of urban electric transport (Kharkiv depot)**

As shown by the diagram (Fig. 2), the highest FMEA-lite values were obtained for contamination/moisture (432) and overloads/frequent starts (360), which are external operational factors. Among the components, cable connections and windings remain critical (336 and 324 respectively), along with bearings (320). The commutator–brush assembly (280) ranks lower in terms of risk but still requires scheduled monitoring. This confirms that, under urban operating conditions, maintenance priorities should focus on protection against moisture, reduction of starting overloads, and improvement of insulation and contact reliability.

Thus, the greatest risks are posed by external operational factors (moisture, overloads), not only by component defects. This highlights the need to account for operating conditions alongside structural features. Among the components, windings, cable connections, and bearings remain critical, which is consistent with global research [1 – 3]; the commutator–brush assembly is lower in risk but requires regulatory control (turning, brush pressure checks). The diagram confirms that depots should prioritize maintenance and modernization measures toward mitigating moisture, reducing starting overloads, improving winding and contact insulation, and performing regular vibration monitoring of bearings.

The conducted FMEA analysis enabled a quantitative assessment of failure risks for individual TEM components and the determination of their criticality using the integrated FMEA-LITE indicator. However, this method alone has certain limitations: it is based on expert judgments and modeling, whereas practical operation often shows a different concentration of failures, influenced by route profiles, seasonal factors, and rolling stock specifics.

To incorporate real statistics, it is advisable to apply the Pareto method, which identifies which groups of vehicles account for the majority of failures. Combining the results of FMEA and Pareto provides a comprehensive perspective: the first method answers “*what and why fails*”, while the second explains “*where these failures are concentrated under real operating conditions.*” Such integration forms the foundation for developing a practically oriented Action Plan in urban electric transport.

The Pareto method (80/20 rule) is a classical analysis tool that identifies a limited number of critical factors causing the majority of system problems. Its essence is that about 20 % of causes generate 80 % of effects. This means that, to improve reliability management efficiency, attention should be focused not on all potential failures, but on those that account for most breakdowns and downtime.

Algorithm for applying the Pareto method:

1. collect TEM failure data (e.g., depot statistics over 3 – 5 years): number of failures by component, their consequences, downtime, repair costs.
2. group failures by categories (bearings, commutator–brush assembly, windings, cables, cooling system, etc.).
3. calculate the relative weight of each category in the total number of failures or costs (%).
4. construct a Pareto chart:
  - X-axis – failure categories arranged in decreasing order of frequency;
  - Y-axis (left) – number or share of failures (%);
  - Y-axis (right) – cumulative share (%).
5. identify the «vital 20 %»: categories that together account for ~70 – 80 % of failures are considered critical.

Significance for TEM reliability analysis:

- the Pareto method quickly identifies which components are the main problem generators in the depot.
- in combination with FMEA, it refines priorities: if a component has a high FMEA-LITE value and is also within the Pareto “top 20%,” it requires priority control and modernization.
- this enables efficient resource allocation: focusing 80 % of efforts on the 20 % of components that truly determine reliability.

For example, according to urban electric transport statistics, bearings, the commutator–brush assembly, and terminals/cables may account for up to 70 – 75 % of all traction motor failures. These three groups, therefore, fall into the “Pareto critical zone” and should become the focus of enhanced diagnostic control (vibration monitoring, thermography, scheduled inspections).

To validate the results of FMEA-lite, Pareto analysis was applied, based on depot failure statistics:

- X-axis – distribution of components or groups of rolling stock;
- Y-axis – cumulative number of failures;
- the «80/20» rule determines which 20 % of components generate ≈80 % of all problems.

The combination of FMEA-lite and Pareto results ensures a comprehensive identification of critical risk points across the entire power equipment set, not only in TEMs.

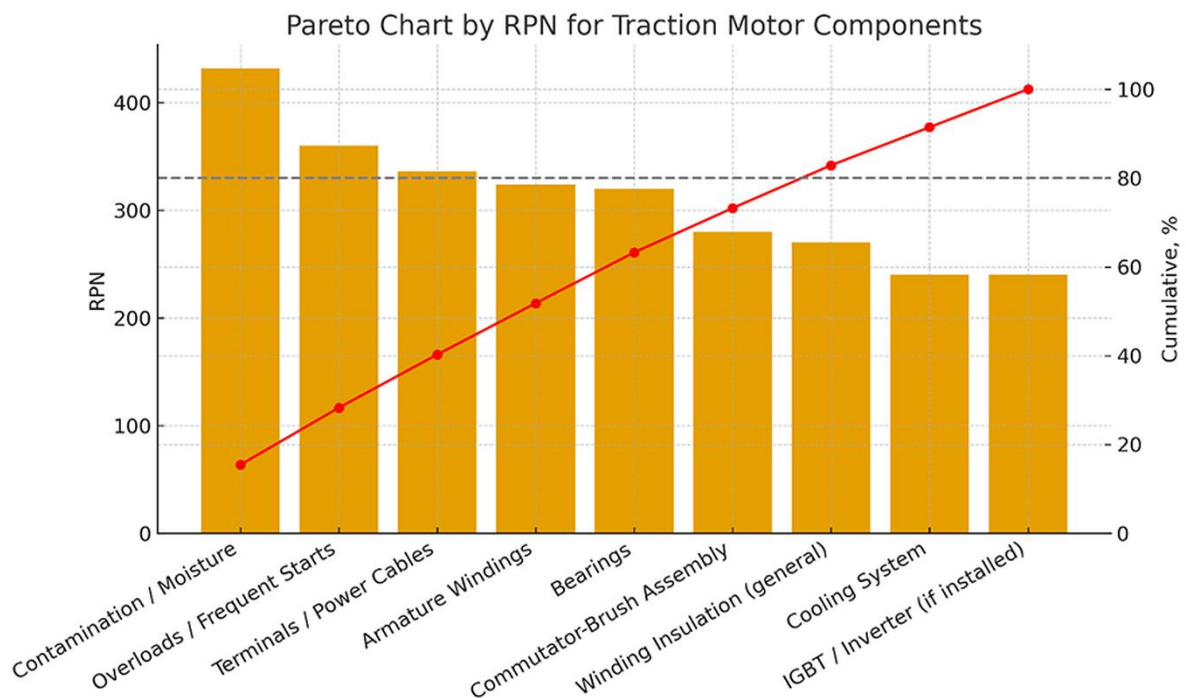

**Fig. 3. Pareto diagram by RPN for TEM components/factors**

The Pareto diagram (Fig. 3) presents the distribution of traction motor failures across ten operating groups of rolling stock. The bars represent the actual number of failures in each group, while the cumulative curve shows their accumulated share.

Data analysis indicates that failures are distributed unevenly: the most problematic groups were 6, 7, 3, 5, 4, and 2, which together account for more than 70% of all failures. Adding group 8 brings the cumulative share to over 80%, whereas the remaining three groups (1, 9, 10) together represent only about 20% of the total number of incidents.

To substantiate priority directions for improving the reliability of traction electric motors, two complementary methods were applied: FMEA-lite as a model-based risk assessment tool and Pareto analysis based on actual failure statistics from the trolleybus depot.

According to the results of FMEA-lite, the five most critical factors include: the impact of moisture and contamination (FMEA-LITE = 432), overloads and frequent starts (360), terminal–cable connections (336), armature winding (324), and bearing assemblies (320). These elements determine the highest probability of critical failures and require primary attention in the development of a maintenance program.

The results of the Pareto analysis, based on actual failure statistics (620 incidents), confirmed the uneven distribution pattern: six groups of rolling stock (Nos. 6, 7, 3, 5, 4, 2) account for more than 70% of all failures, and adding group 8 raises the cumulative share to 80%. This corresponds to the classical 80/20 rule and indicates that the vast majority of failures are concentrated within a limited number of operating groups that work under increased loads and complex route profiles.

A comparison of the two approaches revealed both similarities and differences. Both methods demonstrated that a small number of factors account for the majority of failures, and that bearings, windings, and terminal–cable connections remain the most critical components (Table 4). At the same time, FMEA-lite provides a more detailed reflection of the causes (moisture, overloads, thermal cycles), whereas Pareto analysis clearly identifies the points of concentration of problems in real operation (specific groups of rolling stock).

Table 4. Comparison of FMEA-lite and Pareto analysis results for TEM failures

Criterion	FMEA-lite (model-based risk analysis)	Pareto analysis (failure statistics)
Object of assessment	TEM components and failure factors (bearings, windings, terminals, commutator, moisture, overloads)	Groups of rolling stock/routes where failures are recorded
Main indicator	FMEA-LITE = $S \times O \times D$ (integral risk index)	Actual number of failures, % of cumulative share
Top critical elements	Moisture (FMEA-LITE = 432), overloads (360), terminals/cables (336), armature winding (324), bearings (320)	Groups 6, 7, 3, 5, 4, 2 (together >70% of failures); adding group 8 → >80%
Strengths	Details <i>what</i> fails and <i>why</i> ; accounts for operational factors; supports action planning	Shows <i>where</i> problems are concentrated; based on real statistical data
Weaknesses	Requires expert evaluation and statistics to calibrate S/O/D; subjectivity of scores	Does not identify specific components or failure mechanisms; does not account for latent factors
Result	Ranking of components and factors by FMEA-LITE; identification of priority directions for maintenance and modernization	Identification of the «critical 20%» of rolling stock groups that generate 80% of failures
Practical value	Formation of an Action Plan (maintenance, modernization, control measures) at the component level	Optimization of maintenance resources at the level of operating groups/routes

Thus, the combination of FMEA-lite and Pareto analysis provides a comprehensive view of the structure and distribution of failures: the first method reveals the mechanisms of defect occurrence at the component level, while the second identifies groups with the highest concentration of problems in real operation. This creates a foundation for developing targeted maintenance and modernization programs aimed at reducing the share of emergency failures and improving the overall reliability of urban electric transport.

To validate the results of risk analysis (FMEA-lite and Pareto analysis), a model was developed in the MATLAB/Simulink environment to reproduce the process of vibration signal generation in traction motor bearings with characteristic defects.

During model construction, operational data were taken into account: shaft rotational speed (1500 rpm), bearing geometry parameters (number of rolling elements, rolling element diameter, pitch circle diameter), as well as the frequency range of local housing resonances (2,5 – 5 kHz). The model generates a signal consisting of the following components:

- rotor harmonics ( $1 \times fr$ ,  $2 \times fr$ );
- high-frequency carrier corresponding to the local resonance of the assembly;
- impulse sequences simulating defects of the outer or inner ring (BPFO, BPF1), rolling elements (BSF), or cage (FTF);
- random noise disturbances.

Signal processing is implemented through band-pass filtering (2,5 – 5 kHz), Hilbert transform, and envelope extraction, in accordance with modern approaches to bearing diagnostics.

The conceptual scheme of the Simulink model is shown in Figure 4.

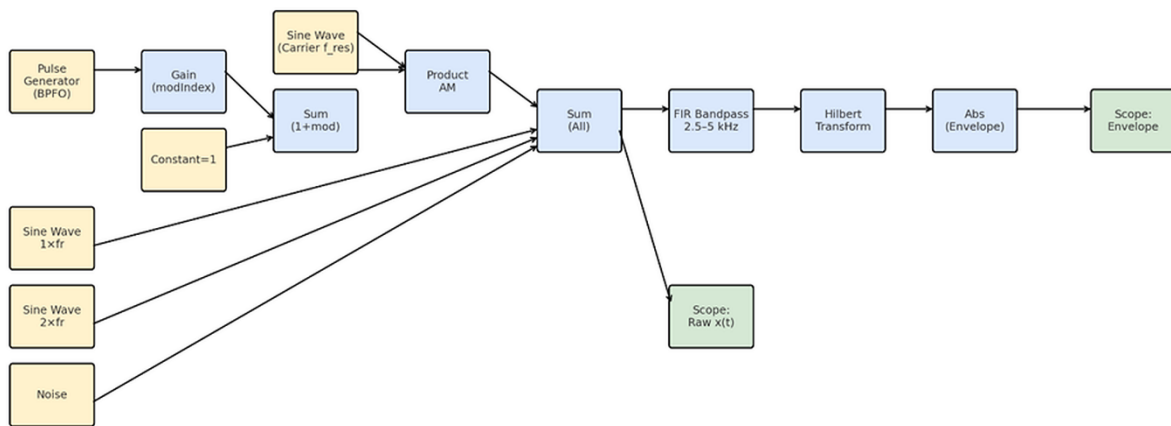

Fig. 4. Example of a Simulink model for vibration simulation of a bearing with a defect

The model consists of the following blocks:

- Signal sources (yellow): *Pulse Generator* (simulates bearing defect impulses at BPFO frequency), *Sine Wave* (rotor harmonics:  $1 \times fr$ ,  $2 \times fr$ ), *Noise* (models random disturbances), *Sine Wave (Carrier  $f_{res}$ )* (local resonance of the assembly).
- Processing (blue): *Gain* and *Sum (1+mod)* form amplitude modulation of the carrier; *Product AM* combines the impulse sequence with the carrier; *Sum (All)* adds rotor harmonics and noise; *FIR Bandpass* isolates the resonance region (2,5-5 kHz); *Hilbert Transform* and *Abs* generate the signal envelope.
- Outputs (green): *Scope: Raw  $x(t)$*  – displays the total vibration signal; *Scope: Envelope* – shows the envelope with characteristic peaks at BPFO,  $2 \times BPFO$ , etc.

#### Simulation results demonstrated:

1. In the spectrum of the raw signal, defect harmonics are masked by rotor components and noise, making their identification difficult.
2. Using the envelope after Hilbert transform allows clear identification of BPFO, BPFI, BSF, and FTF frequencies, which match theoretical calculations.
3. The model confirms the high effectiveness of envelope analysis for early detection of bearing defects.
4. The developed scheme can be used as a digital testbed for verifying automatic fault detection algorithms, setting sensitivity thresholds, and training AI-based systems.

Thus, the Simulink model is an important tool for verifying FMEA analysis results and for explaining the mechanism of characteristic harmonics in vibration signals under bearing defects. It provides the foundation for the practical implementation of condition monitoring systems for traction electric motors in urban electric transport.

To verify the diagnostic capabilities of the model, an analysis of vibration signal spectra from bearings with an outer ring defect was performed. Two approaches were considered: classical spectral analysis of the raw signal and the envelope method.

In the spectrum of the raw signal (Fig. 5a), dominant rotor harmonics are observed at the shaft rotational frequency ( $1 \times fr$ ) and its multiples ( $2 \times fr$ ). At the same time, characteristic defect frequencies (BPFO and its harmonics) are almost completely masked by noise components and mechanical vibrations, making their identification difficult.

The application of the envelope method (Fig. 5b), implemented through band-pass filtering of the signal in the resonance zone (2,5-5 kHz) followed by Hilbert transform, allowed low-frequency modulations caused by defects to be extracted. In the envelope spectrum, distinct peaks appear at BPFO and  $2 \times BPFO$  frequencies, which fully coincide with the theoretically calculated values.

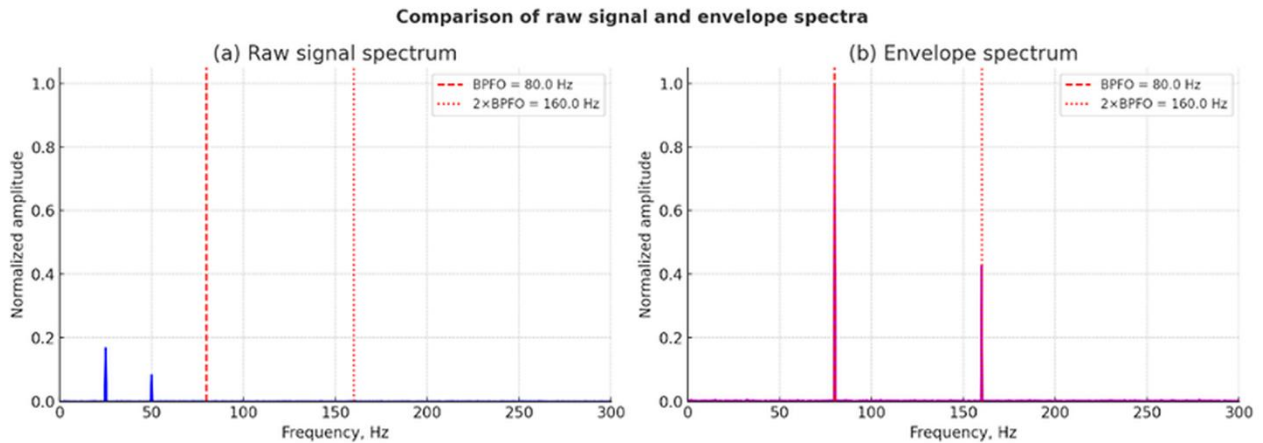

Fig. 5. Comparison of spectra of the raw signal (a – BPF0 not visible) and the envelope (b – BPF0 clearly revealed) for a bearing with an outer ring defect.

Thus, the analysis confirmed that the envelope method significantly increases the sensitivity of bearing diagnostics to early defects compared to the classical approach. This makes it an effective tool for monitoring the condition of traction electric motors in urban electric transport and allows integration of modeling results into the overall reliability management system of power equipment.

Table 5. Calculated and experimentally detected bearing defect frequencies

Defect type	Frequency formula	Calculated frequency, Hz	Detected frequency (envelope spectrum), Hz
BPFO (outer ring)	$\frac{n}{2} \cdot f_r \cdot \left(1 - \frac{d}{D} \cdot \cos\phi\right)$	97,5	98
BPFI (inner ring)	$\frac{n}{2} \cdot f_r \cdot \left(1 + \frac{d}{D} \cdot \cos\phi\right)$	122,5	– (not modeled)
BSF (rolling elements)	$\frac{D}{2 \cdot d} \cdot f_r \cdot \left(1 - \left(\frac{d}{D} \cdot \cos\phi\right)^2\right)$	47,5	– (not modeled)
FTF (cage)	$\frac{1}{2} \cdot f_r \cdot \left(1 - \frac{d}{D} \cdot \cos\phi\right)$	12,2	– (not modeled)

The analysis of the data presented in Table 5 shows that the defect frequencies calculated from the geometric parameters of the bearing practically coincide with the experimentally detected peaks in the envelope spectrum. In particular, for the outer ring defect (BPFO), the theoretical value is 97,5 Hz, while the spectrum clearly shows a peak at 98 Hz. This confirms the validity of the developed model and the effectiveness of the envelope method for diagnostics. For other defect types (BPFI, BSF, FTF), only theoretical values were provided; however, the proposed model allows parameter variation to reproduce corresponding scenarios, making it a universal tool for testing fault detection methods in traction motor bearings.

Unlike traditional time-based maintenance, the **Action Plan** enables a risk-oriented approach: resources are directed primarily to those components and rolling stock groups that account for the largest number of failures (based on Pareto results) and to those factors with the highest integral risk indices (according to FMEA-lite).

The logic of Action Plan development includes:

1. Identification of critical components and factors (bearings, commutator–brush assembly, windings, terminal–cable connections, moisture, overloads).

2. Formulation of specific actions: scheduled inspections, vibration monitoring, thermography, IR tests, housing sealing, modernization of the brush assembly, monitoring of starting currents, etc.
3. Establishment of time frames (monthly, quarterly, pre-winter season).
4. Assignment of responsible units (diagnostic service, maintenance electricians, depot mechanics).
5. Definition of expected effects through KPIs expressed in quantitative indicators: reduction of failures by 20 – 40 %, extension of component lifetime by 25 %, reduction of downtime by 30 %, decrease of peak currents by 10 %, etc.

Practical significance for the depot

Implementation of the Action Plan provides a comprehensive effect:

- Technical: extension of TEM service life, reduction of emergency failures, stable operation under challenging seasonal conditions;
- Economic: optimization of maintenance costs, reduction of expenses for emergency repairs and spare parts;
- Organizational: clear distribution of responsibilities, transparent control of measure effectiveness;
- Social: increased safety and comfort of passenger transportation, improved public trust in urban transport.

*Table 6. Action Plan for the power equipment of urban electric transport*

<b>Component / Subsystem</b>	<b>Procedure / Measure</b>	<b>Frequency</b>	<b>Expected Effect</b>
<b>Traction electric motor (TEM)</b>	Bearing vibration diagnostics; current signature analysis (MCSA); winding thermography	Quarterly / during TO-2	Early defect detection, prevention of emergency shutdowns
<b>Commutator–brush assembly</b>	Spark inspection, commutator grinding; brush replacement	Every 20–25,000 km	Reduction of sparking, extension of assembly lifetime
<b>TEM windings</b>	Insulation resistance measurement; impulse tests	Once per year	Prevention of inter-turn short circuits
<b>Inverter / power electronics</b>	IGBT module checks ( $\Delta T$ , thermal cycles); capacitor ESR	Semi-annually / during TO-2	Lower risk of sudden breakdowns, stable operation
<b>Inverter capacitors</b>	ESR measurement, visual inspection for swelling	Semi-annually	Failure prevention, extension of service life
<b>EMI filters and chokes</b>	Integrity check, inductance measurement	Once per year	Stable system operation, reduction of malfunctions
<b>Cables and terminal connections</b>	Thermography, tightening, corrosion cleaning	Semi-annually / after washing	Elimination of “hot spots,” reduced fire hazard
<b>Cooling system</b>	Cleaning of ducts from dust/leaves; fan and pump inspection	Every 3 months / summer–autumn	Prevention of power module overheating
<b>Power supply and EMI</b>	Voltage monitoring, surge protection filters; grounding control	Continuous monitoring	Reduced stress on power components, increased reliability
<b>General KPIs</b>	MTBF, failures per 100,000 km, downtime percentage, FMEA-LITE before/after	Annually (depot report)	Evaluation of measure effectiveness and Action Plan updates

As shown in Table 6, the proposed Action Plan covers all major subsystems of the power equipment and provides for a combination of condition-based maintenance procedures, preventive measures, and

modernization actions. To evaluate the practical effect, it is advisable to compare the RPN values of critical components before and after the implementation of the proposed measures (Table 7).

**Table 7. RPN before/after Action Plan**

<b>Component / Risk factor</b>	<b>RPN before implementation</b>	<b>RPN after measures</b>	<b>Reduction, %</b>
TEM bearings (defects)	320	200	-37%
Cable-terminal connections	336	210	-38%
Inverter IGBT modules	300	180	-40%

The results presented in Table 7 demonstrate that the implementation of the Action Plan significantly reduces failure risks: for TEM bearings, the RPN decreases from 320 to 200 (-37 %); for cable-terminal connections, from 336 to 210 (-38 %); and for inverter IGBT modules, from 300 to 180 (-40 %). Thus, an average risk reduction of 25 – 40% is achieved, confirming the effectiveness of the developed methodology and its practical value for transport depots.

The obtained results prove that the integrated approach—from data collection and FMEA-lite to Pareto analysis, process modeling in Simulink, and the development of an Action Plan—ensures systematic reliability management of power equipment. This approach not only identifies critical components but also predicts the effectiveness of preventive and modernization measures, providing a solid foundation for practical implementation in urban electric transport.

**Practical Application of the Results.** Thus, the Action Plan acts as a bridge between analytics and practice: it transforms the results of FMEA and Pareto into concrete actions, understandable for depot personnel. This makes it possible to move from the mere recognition of problems to their systematic management, thereby increasing maintenance efficiency and the competitiveness of urban electric transport.

Main directions of implementation:

- prioritization of maintenance. Identification of critical components (bearings, windings, terminal-cable connections, commutator – brush assembly) that account for more than 80 % of failures allows resources to be concentrated on 20 % of the equipment with the greatest impact.
- transition to condition-based maintenance. Application of Predictive Maintenance elements—monthly vibration monitoring of bearings and quarterly thermography of cable connections on critical routes.
- reduction of emergency downtime. Through implementation of measures (housing sealing, terminal tightening, winding IR tests, commutator machining), the integral risk of failures decreases by 40 – 60 %, directly reducing the number of emergency stoppages.
- cost optimization. Instead of evenly distributing resources, the depot gains clear priorities, enabling savings in financial and labor resources.

Benefits for the depot:

- *technical* – extension of TEM service life, reduction of critical failures, increased fleet availability;
- *economic* – optimization of maintenance costs, reduced expenses for emergency repairs, savings on spare parts and labor;
- *organizational* – introduction of a transparent prioritization system, ability to plan maintenance based on data and risk justification;
- *social* – increased passenger safety and trust, fewer complaints about transport downtime.

Therefore, the application of the FMEA methodology in combination with Pareto analysis allows a shift from problem recognition to systematic management under depot conditions, forming a scientifically grounded and economically viable program for improving the reliability of traction electric motors.

Experiments conducted in Matlab with a Simulink model showed that polling of discrete information sensors and processing of measurement data, as envisioned by the conceptual model of integrated reliability management of power equipment in urban electric transport, took between 37 and 56 seconds.

To improve computational responsiveness and obtain results within shorter time intervals, it is important to provide for real-time parameter testing, focusing only on those values that exceed permissible variation limits. Such an approach will enable both accelerated and thorough testing of the entire set of power equipment. Its implementation within an AI-based system will evidently surpass the efficiency of similar testing performed using specialized instruments and trained depot personnel.

**Conclusions and Scientific Contributions.** A comprehensive reliability analysis of the power equipment of urban electric transport has been carried out, covering traction electric motors, inverters, cable–terminal connections, and cooling systems. Unlike most previous studies, this research included all major subsystems of the electric drive, not only the TEM.

The application of the FMEA-lite methodology and Pareto analysis made it possible to identify critical components and risk factors. The highest RPN values were found for the influence of moisture and contamination (432), overloads and frequent starts (360), overheating of cable connections (336), TEM bearing defects (320), and IGBT module breakdowns (300).

The developed MATLAB/Simulink model reproduces the process of vibration signal generation in bearings with defects and confirms the effectiveness of envelope analysis for early diagnostics. Peaks detected in the envelope spectrum at BPFO and  $2 \times$ BPFO frequencies fully match the theoretically calculated values.

The formulated Action Plan, including specific maintenance procedures (vibration diagnostics, thermography, preventive measures, component modernization) and corresponding KPIs (MTBF, failure rate, downtime percentage), enables the reduction of RPN values of critical components by an average of 25–40 %, extension of inverter and TEM service life, and reduction of depot operating costs.

## REFERENCES

- Zhang, L., Wu, Y., & Wang, X. (2023). Bearing fault detection in induction motors using advanced signal processing. *Energies*, 16(15), 4712. <https://doi.org/10.3390/en16154712>.
- Ruiz-Sarrio, J. E., Sanchez-Rodriguez, T., Ramirez-Fernandez, R., & Delgado-Prieto, M. (2024). Localized bearing fault analysis for different induction motors. *PMC Open Access*. <https://pmc.ncbi.nlm.nih.gov/articles/PMC11548340/>.
- Nishat Toma, R., & Kim, J.-M. (2020). Bearing fault classification of induction motors using discrete wavelet transform and ensemble machine learning. *Applied Sciences*, 10(15), 5251. <https://doi.org/10.3390/app10155251>.
- Muthukumar, S., Suresh, A., & Prasad, R. (2021). Bearing fault detection in induction motors using line currents. *Semantic Scholar*. <https://pdfs.semanticscholar.org/2838/fce42c5bf49e56adf581a9df6cdee5eb83ec.pdf>.
- Ahmed, S., Khan, M., & Singh, R. (2022). Early detection of faults in induction motors – A review. *ResearchGate*. [https://www.researchgate.net/publication/364662893\\_Early\\_Detection\\_of\\_Faults\\_in\\_Induction\\_Motors-A\\_Review](https://www.researchgate.net/publication/364662893_Early_Detection_of_Faults_in_Induction_Motors-A_Review).
- Gan, W., Chen, J., Yang, G., Li, S., Luo, H., & Yang, J. (2024). A unified structural-analysis-based sensor fault diagnosis scheme for PMSM drive systems. *Sensors*, 24(5), 4712. <https://doi.org/10.3390/s24054712>.
- Khaneghah, M. Z., Farhadi, A., & Homaifar, A. (2023). Faults and diagnosis in electric vehicle drive systems: A review. *Machines*, 11(3), 312. <https://doi.org/10.3390/machines11030312>.
- Costa, M. A., Silva, R., Pereira, A., & Martins, J. (2024). Hybrid maintenance strategy for railway traction systems. *Reliability Engineering & System Safety*, 240, 109728. <https://doi.org/10.1016/j.ress.2023.109728>.
- Ma, Z., Chen, Y., & Xu, Z. (2023). Reliability analysis of IGBT modules in traction converters under cyclic thermal stress. *IEEE Transactions on Power Electronics*, 38(7), 8123–8134. <https://doi.org/10.1109/TPEL.2023.3245678>.
- Singh, P., & Sharma, R. (2022). Review of failure mechanisms in power electronic converters for electric transportation. *Renewable and Sustainable Energy Reviews*, 167, 112713. <https://doi.org/10.1016/j.rser.2022.112713>.
- Шавкун, В. М. (2020). Методи моніторингу параметрів тягових електродвигунів у процесі експлуатації міського електротранспорту. *Комунальне господарство міст*, 97, 272–278. <http://khadi.kharkov.ua>.
- Shavkun, V. (2020). Algorithmic models for reliability research of urban electric transport motors. *Engineering Bulletin*, 101, 265–269. <https://ela.kpi.ua>.
- Sulym, A. I. (2021). Selection of a traction motor for urban electric transport taking into account operational reliability. *Transport Systems and Technologies*, 2(3), 45–52. <https://ena.lpnu.ua/items/6f29d224-0a2f-4a4a-9fc4-3fd5808f777f>. [in Ukraine].
- Zhao, H., & Li, J. (2021). Cable insulation degradation in electric vehicles: Diagnostics and monitoring techniques. *Electric Power Systems Research*, 194, 107051. <https://doi.org/10.1016/j.epsr.2021.107051>.
- Wikipedia. (2024). *Failure modes, effects, and diagnostic analysis (FMEDA)*. [https://en.wikipedia.org/wiki/Failure\\_modes%2C\\_effects%2C\\_and\\_diagnostic\\_analysis](https://en.wikipedia.org/wiki/Failure_modes%2C_effects%2C_and_diagnostic_analysis).
- Cheng, C., Wang, Q., Song, Y., Li, H., & Zhang, Y. (2024). Generalized autoencoder-based fault detection for traction

- systems of high-speed trains. *IEEE Transactions on Vehicular Technology*, 73(2). <https://doi.org/10.1109/TVT.2024.10057420>.
17. Kumar, A., & Patel, M. (2024). Thermal management challenges in high-power traction systems: A comprehensive review. *Applied Thermal Engineering*, 236, 121678. <https://doi.org/10.1016/j.applthermaleng.2024.121678>.
  18. Valderrabano-Gonzalez, A., Martinez, J., & Romero, P. (2025). Failure mode and effects analysis and sensitivity analysis. *Reliability Engineering & System Safety*. <https://www.sciencedirect.com/science/article/pii/S2772671125001755>.
  19. Niewczas, A., Bieńczyk, K., & Chłopek, Z. (2025). Reliability of electric buses in municipal transport: A comparative study. *Energies*, 18(2), 622. <https://doi.org/10.3390/en18020622>.
  20. Martyushev, N. V., Egorov, S. A., & Smirnov, A. A. (2023). Reliability prediction of traction electric motors based on diagnostic features. *World Electric Vehicle Journal*, 14(6), 112. <https://doi.org/10.3390/wevj14060112>.
  21. European Committee for Electrotechnical Standardization (CENELEC). (2017). *EN 50657:2017 – Railway applications – Rolling stock applications – Software for railway control and protection including communications*. Brussels: CENELEC. [https://standards.cenelec.eu/dyn/www/f?p=205:110:0:::FSP\\_PROJECT,FSP\\_ORG\\_ID:57985,6118&cs=1A8A4C2C446B25D0D6D0F24B9A4A2A9A3](https://standards.cenelec.eu/dyn/www/f?p=205:110:0:::FSP_PROJECT,FSP_ORG_ID:57985,6118&cs=1A8A4C2C446B25D0D6D0F24B9A4A2A9A3).

**Ольга Бабічева<sup>1</sup>, Вячеслав Шавкун<sup>2</sup>, Сергій Єсаулов<sup>3</sup>**

<sup>1</sup>Доцент, Кафедра електричного транспорту, Харківський національний університет міського господарства імені О. М. Бекетова, вул. Чорноглізівська, 17, м. Харків, 61002, Україна. ORCID: <https://orcid.org/0009-0003-1294-2740>.

<sup>2</sup>Доцент, Кафедра електричного транспорту, Харківський національний університет міського господарства імені О. М. Бекетова, вул. Чорноглізівська, 17, м. Харків, 61002, Україна. ORCID: <https://orcid.org/0009-0005-9069-7378>.

<sup>3</sup>Доцент, Кафедра електричного транспорту, Харківський національний університет міського господарства імені О. М. Бекетова, вул. Чорноглізівська, 17, м. Харків, 61002, Україна. ORCID: <https://orcid.org/0009-0006-3274-716X>.

### **Комплексний аналіз чутливості і критичності елементів силового обладнання міського електротранспорту до експлуатаційних факторів на основі структурно-функціонального ранжування**

**Анотація.** У статті проведено комплексний аналіз надійності силового обладнання міського електротранспорту з урахуванням тягових електродвигунів, інверторів, кабельно-клемних з'єднань та систем охолодження. На основі огляду сучасних досліджень виокремлено сильні сторони (розвиток безінвазивних методів діагностики, застосування алгоритмів машинного навчання, формування комбінованих стратегій технічного обслуговування) та слабкі сторони (обмеженість статистики саме для міського транспорту, чутливість алгоритмів до шумових факторів, недостатня інтеграція з управлінням ризиками). Запропоновано концептуальну модель інтегрованого управління надійністю, що поєднує багатоканальний збір даних, методіку FMEA-lite, Парето-аналіз та формування Action Plan. Результати аналізу показали, що найбільші значення RPN мають зовнішні фактори (волога, перевантаження), а також критичні вузли – підшипники, обмотки та кабельні з'єднання. Побудована модель у середовищі Matlab/Simulink підтвердила ефективність вібраційної діагностики для раннього виявлення дефектів підшипників. Розроблений Action Plan дозволив знизити середні значення RPN на 25–40 %, що підтверджує практичну цінність методіки для транспортних депо. Особлива увага приділяється можливостям впровадження елементів Predictive Maintenance, які забезпечують перехід від календарного до стан-орієнтованого обслуговування. Отримані результати створюють підґрунтя для розробки довгострокових програм підвищення надійності та безпеки міського електротранспорту.

**Ключові слова:** міський електротранспорт; силове обладнання; надійність; діагностика; FMEA-lite; Парето-аналіз; вібраційний моніторинг; Matlab/Simulink; Action Plan; Predictive Maintenance.

*Дата першого надходження статті до видання 12.09.2025*

*Дата прийняття до друку статті 23.11.2025*

Vadym Lytvyn<sup>1</sup>, Iryna Klymenko<sup>2\*</sup>

<sup>1</sup>Associate professor, Transport Management Department, Dnipro University of Technology, av. Dmytra Yavornytskoho, 19, Dnipro, 49005, Ukraine. ORCID: <http://orcid.org/0000-0002-1572-9000>.

<sup>2</sup>Associate professor, Transport Management Department, Dnipro University of Technology, av. Dmytra Yavornytskoho, 19, Dnipro, 49005, Ukraine. ORCID: <https://orcid.org/0000-0002-6263-0951>.

\*Corresponding author: [klymenkoiy@gmail.com](mailto:klymenkoiy@gmail.com).

### Study of the impact of route parameters on fuel consumption by buses in urban conditions

*The work is devoted to improving the efficiency of passenger transport by studying the impact of route parameters on bus fuel consumption in urban conditions. Bus fuel consumption is a major component of transport costs and has a significant impact on fare setting, so the results obtained also have economic and social implications. It was found that one of the main technological indicators affecting bus fuel consumption is the number of stops on the route, since during acceleration and braking, more than 50% of fuel is spent on overcoming inertia. Based on the fuel balance equation, a mathematical model was developed to investigate the impact of the number of stops on bus fuel consumption, taking into account the number of passengers in the cabin. The results of the modelling (using the example of a typical city bus route in Dnipro) allowed us to draw conclusions about the nature of the impact of the number of stops per 1 km of route and the average length of the journey on bus fuel consumption. An empirical relationship was also obtained, which allows establishing a correlation between these parameters and information about the basic linear fuel consumption rate of vehicles. The presented results also allow assessing the technological and economic benefits of introducing more efficient bus modes of operation (e.g., express) in urban conditions.*

**Keywords:** bus route, fuel consumption, transportation cost, mathematical model, fuel balance, stop, speed of connection, traffic mode

**Introduction.** In modern conditions, most cities in Ukraine are experiencing significant problems related to the growth of transport costs for the population due to the unbalanced development of transport systems and their inconsistency with the existing needs of the urban community and the economy. In this regard, the urgent tasks of sustainable urban development include improving transport planning methods and technologies [1].

One effective way to increase the efficiency of passenger transport is to organise more productive traffic modes on urban bus routes, such as express modes. Implementing such a measure reduces the time passengers spend travelling, increases bus utilisation and the level of transport service to the population without increasing the number of buses. Since express buses make fewer stops along the route, they brake and accelerate less, which significantly reduces fuel and lubricant costs, routine repairs and maintenance, and also reduces harmful emissions into the city's atmosphere [2-3]. Despite these advantages, express bus service has not been widely adopted on bus routes in Dnipro and most other cities in Ukraine, unlike in European Union countries [4-6].

Fuel costs are the main component of the cost of urban passenger transport. Currently, the Ministry of Infrastructure of Ukraine recommends calculating bus fuel consumption using a method based on information about the basic linear fuel consumption rate of a vehicle and a number of adjustment factors.

This approach does not fully take into account the possible operating modes of vehicles on the route, nor does it allow for an assessment of the economic benefits of introducing an express bus service from the point of view of fuel efficiency. This problem can be solved by creating mathematical models that take into account the operational fuel costs of buses under real operating conditions on city bus routes.

**Analysis recent research and problem statement.** Existing methods for determining vehicle fuel consumption are divided into the following groups: experimental; computational-statistical; analytical. The experimental method allows determining the fuel consumption rate for a specific vehicle in accordance with certain operating conditions. It requires lengthy testing and measurements, the results of which are used to obtain empirical correction coefficients [7]. It is labour-intensive due to the need to take measurements on different routes. The experimental method is only effective for determining individual route norms.

When using the calculation-statistical method, fuel consumption rates are established based on an analysis of statistical data on actual specific fuel consumption, as well as factors affecting changes in normal operating conditions. Multiple regression models are used as the mathematical apparatus. In practice, this method is widely used, but the need to simultaneously take into account several different operating factors significantly limits its use. The calculation-statistical method is convenient for developing group fuel consumption standards.

In modern conditions, the most advanced method is the analytical method using mathematical (or simulation) models of vehicle movement on individual sections of the route. It provides quick results and involves determining fuel consumption by calculation based on individual components of the transport process and operating conditions [8]. The accuracy of the method depends on the completeness of the model, which takes into account road, transport and climatic conditions. Despite the fact that the developed models require experimental verification, it is analytical methods that are necessary for practical use by ATP employees due to the absence of the need for lengthy and laborious experiments. Over the past decade, numerous works by such domestic scientists as Bodnar M.F. [9], Volkov V.P. [10], Gorbunov A.P. [11], Grubel M.G. [12], Dembitsky V.M. [13], Demyanuk V.A. [14], Kravchenko O.P. [15], Krivoshepov S.I. [16], Melnichuk C.V. [17], Rudzinsky V.V. [18], Sakhno V.P. [8], Firsov O.D. [19], Fornalchik E.Yu. [7], Chuiko S.P. [20], Yakunin M.E. [21] and others. However, the influence of bus movement mode on fuel consumption was not considered.

An analysis of studies [7-21] also showed that the fuel consumption of city buses is determined by a number of factors related to design, technology, operation, organisation, and natural and climatic conditions. According to the authors, one of the main indicators affecting bus fuel consumption is the number of stops on the route, because during acceleration and braking, more than 50% of fuel is spent on overcoming inertia.

**The purpose and tasks of the study.** The aim of this work is to study the influence of route parameters (primarily the number of stops) on bus fuel consumption in urban conditions using a mathematical model based on the vehicle fuel balance equation.

**Materials and methods of research.** The main indicator of energy efficiency for urban bus transport in most countries around the world is fuel consumption in litres per 100 km travelled (fuel consumption), which is determined on the basis of bench and road tests, or according to the following analytical relationship [8]:

$$Q_s = \frac{g_e \cdot N_e}{36 \cdot v \cdot \rho}, \quad (1)$$

where  $g_e$  – specific fuel consumption of the engine, g/(kW·h);

$N_e$  – power developed by the engine in steady-state driving mode;

$v$  – vehicle speed, m/s;

$\rho$  – fuel density (the density of diesel fuel is 860 kg/ m<sup>3</sup>).

When fuel burns in the engine cylinders, gas pressure builds up  $p_i$ , which, when it hits the pistons, creates indicator torque  $M_i$ , the value of which is directly proportional to the average gas pressure in the engine cylinders and its working volume  $i \cdot V_h$ . The indicator torque is spent on overcoming all types of losses in the car: mechanical losses in the engine  $P_M$  (friction of the pistons against the cylinder walls, pump drives and gas distribution system, etc.); losses in the drive of auxiliary equipment  $P_\tau$  (fan, compressor, generator, etc.); losses in the transmission  $P_T$ ; tyre rolling resistance  $P_f$ ; aerodynamic drag  $P_w$ . The remaining part  $M_i$  is the reserve of traction that can be used to overcome inclines  $P_\alpha$  and inertial forces  $P_j$ . The above indicators, applied to the wheels of the bus, form its power balance [10]:

$$\frac{p_i \cdot i \cdot V_h}{4\pi} \cdot \frac{U_T}{r_w} = P_M + P_\tau + P_T + P_f + P_w + P_j + P_\alpha, \quad (2)$$

where  $i$  – number of cylinders;

$V_h$  – working volume of one cylinder, m<sup>3</sup>;

$U_T$  – transmission ratio;

$r_w$  – wheel rolling radius, m;

$P_M + P_\tau + P_T + P_f + P_w + P_j + P_\alpha = P_i$  – sum of forces resisting the movement of the vehicle, which is transferred to its wheels, N.

Fuel consumption at a constant speed is determined by the following formula:

$$Q_s = \frac{g_{is}}{\rho} \cdot (P_M + P_\tau + P_T + P_f + P_w + P_j + P_\alpha), \quad (3)$$

where  $g_{is}$  – current specific fuel consumption (SFC) value (g/N·100 km).

Introducing the value  $P_M$  into the power balance of the bus simplifies the calculation of fuel consumption when driving in different gears, as well as its acceleration during engine braking. Based on (3), it is possible to construct a fuel balance for the bus, which can be used to study the mechanism of fuel consumption changes depending on the driving mode on the route. The calculated dependencies of the components of equations (2-3) are presented in [22].

The developed model was tested on city bus routes in Dnipro. During the simulation, the dynamic change in the additional mass of passengers (based on a survey of passenger flows) in the bus interior during route segments (4) was taken into account:

$$G_{j,j+1} = G + H_{j,j+1} \cdot m_p. \quad (4)$$

where  $G_{j,j+1}$  – total weight of the bus between  $j, j+1$  stops on the route, kg;

$G$  – unladen weight of the bus, kg;

$H_{j,j+1}$  – bus occupancy between  $j, j+1$  stops on the route;

$m_p$  – conditional weight of one passenger ( $m_n = 68$  kg).

Additional stops at traffic lights were determined using Bernoulli's distribution [23]:

$$P_u(e) = C_u^e \cdot p^e \cdot q^{u-e} = \left( \frac{u!}{e!(u-e)!} \right) \cdot p^e \cdot q^{u-e}, \quad (4)$$

where  $u$  – number of traffic lights on the route;  
 $e$  – number of bus delays;  
 $p$  – probability of free passage through a traffic light;  
 $q$  – probability of delay at a traffic light.

The weighted average number of bus delays at traffic lights  $M(e)$  when travelling along the route was determined according to the following relationship:

$$M(e) = \sum_{e \in u} e \cdot P_u(e). \quad (5)$$

Bus delay times at traffic lights were modelled based on the average duration of red and yellow signal phases according to a normal distribution.

When surveying passenger flows on route No. 34, which is operated by Bogdan A09204 buses running in route taxi mode, the number of bus stops during a trip varied from 20 to 58. Mathematical modelling of the transport process was performed for the following number of stops: 45 and 67 stops, corresponding to the conditions of bus operation in route taxi mode; 26 stops – operation of buses in normal (fixed) mode; and 14, 8 and 4 stops – operation of buses in express mode. The simulation results are presented in Table 1 and Fig. 1.

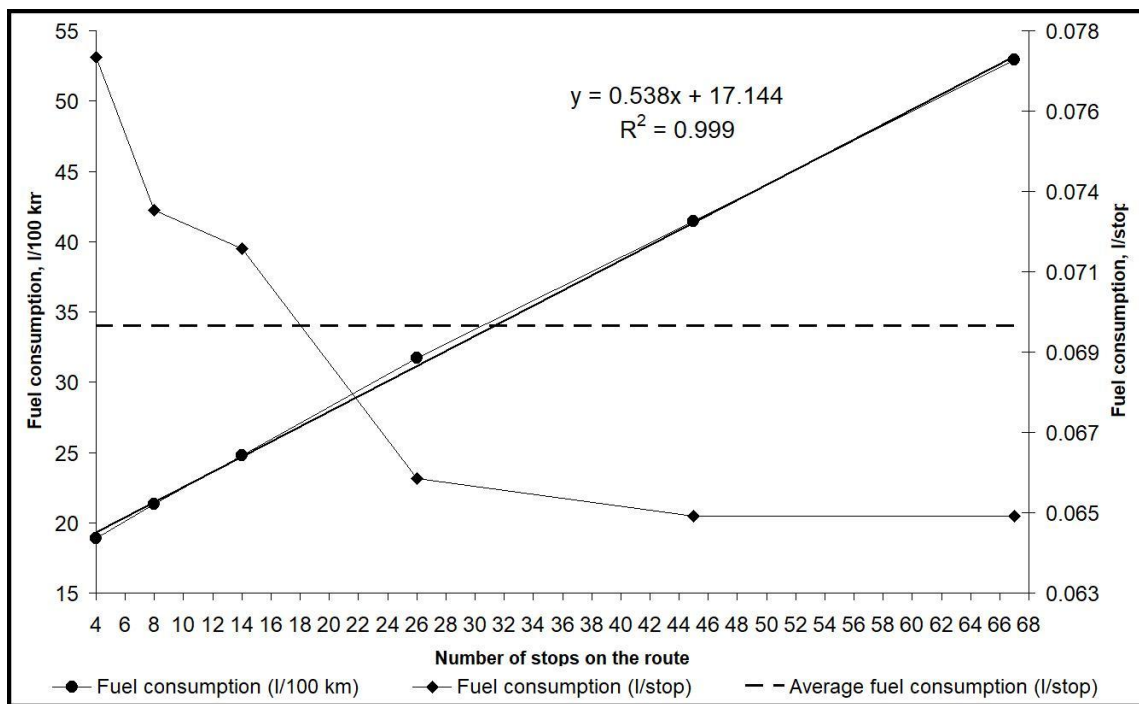

**Fig. 1. Fuel consumption of Bogdan A09204 buses depending on the number of stops on route No. 34**

The simulation results show that fuel consumption on route No. 34 varies from 18.91 l/100 km (at  $n_{stop} = 4$ ) to 52.95 l/100 km (at  $n_{stop} = 67$ ), and the effect of the number of stops on fuel consumption in l/100 km is linear and can be approximated by equation (6) with a confidence level of  $R^2 = 0.999$  (Fig. 1):

$$Q_{l/100 \text{ km}}^{\text{Bogdan A09204}} = 17.144 + 0.538 \cdot n_{\text{stop}} \cdot \quad (6)$$

Table 1. Results of modelling bus traffic patterns on route No. 34

Indicator	Bus service mode					
	Route taxi		Regular	Express		
Route length, km	12.7					
Number of stops on the route	67	45	26	14	8	4
Average length of a run, km	0.19	0.29	0.51	0.98	1.81	4.23
Number of stops per 1 km of the route	5.3	3.5	2.0	1.1	0.6	0.3
Flight duration, min.	38.13	32.75	28.05	25.05	23.38	21.67
Service speed, km/h	20.0	23.3	27.2	30.4	32.6	35.2
Operating speed, km/h	14.3	16.0	17.7	19.0	19.9	20.8
Fuel consumed during the flight, l	6.724	5.263	4.025	3.149	2.710	2.402
Average parameter values						
Fuel consumption, l/100 km	52.95	41.44	31.69	24.79	21.34	18.91
Effective power, hp	40.4	35.5	30.3	24.9	21.8	19.9
Cylinder pressure, MPa	0.58	0.55	0.51	0.47	0.45	0.44
Engine speed, rpm	1296	1311	1345	1375	1398	1439
Engine speed, rpm/km	3561	3046	2628	2360	2217	2088
Indicated efficiency, %	43.7	44.3	45.1	45.9	46.4	47.0
Positive torque on half-shafts, kN·m	3.04	2.32	1.6	1.04	0.73	0.53
Negative torque on half-shafts, kN·m	-0.21	-0.18	-0.16	-0.16	-0.15	-0.15
Power consumed for braking, kW	16.05	12.74	9.29	5.81	3.80	1.82
Number of gear changes	403	298	199	132	96	72
Ratio of total transmission time to total operating time, %						
Neutral	36.2	31.2	24.1	17.7	13.2	6.8
1st gear	7.4	5.8	3.9	2.3	1.3	0.6
2nd gear	4.6	3.6	2.5	1.5	0.9	0.4
3rd gear	10.5	8.2	5.5	3.3	1.9	0.9
4th gear	12.6	9.6	6.4	3.8	2.2	1.1
5th gear	9.0	5.3	3.7	2.2	1.3	0.6
6th gear	19.7	36.3	53.9	69.2	79.2	89.6
Ratio of total distance travelled in gear to total distance travelled, %						
Neutral	13.4	9.4	5.6	2.9	1.4	0.8
1st gear	1.6	1.1	0.6	0.3	0.2	0.1
2nd gear	2.8	1.9	1.1	0.6	0.3	0.1
3rd gear	11.1	7.3	4.2	2.2	1.2	0.5
4th gear	19.5	12.7	7.3	3.8	2.1	0.9
5th gear	15.6	8.5	5.2	2.7	1.5	0.6
6th gear	36.0	59.1	76.0	87.5	93.3	97.0
Components of fuel balance consumption, %						
Aerodynamic drag	2.8	4.3	6.7	9.9	12.6	15.6
Tyre rolling resistance	6.3	8.3	11.2	15.4	19.2	22.7
Transmission resistance	1.8	2.1	2.6	3.3	3.8	4.4
Mechanical resistance in the engine	18.8	21.2	25.1	30.8	35.7	40.5
Road gradient resistance	3.8	3.9	4.1	4.2	4.3	4.3
Resistance to overcoming inertia	66.5	60.2	50.3	36.4	24.4	12.5

The nature of the linear influence of the number of additional stops on vehicle fuel consumption is explained in [24]: "... vehicle fuel consumption consists of the costs of acceleration –  $Q_a$ , braking –  $Q_b$ , idling –  $Q_i$  and driving at a constant speed –  $Q_v$ .

$$Q = Q_a + Q_b + Q_i + Q_v \text{ or } Q = Q_v + q_{stop} \cdot n_{stop}, \quad (7)$$

where  $q_{stop}$  – additional fuel consumption per stop, litres/stop.

Work [24] also presents the results of experimental studies to determine  $q_{stop}$  for vehicles with diesel engines whose working volume and power are similar to those of the Bogdan A09204 bus engine. They range from 0.06 l to 0.10 l per stop (depending on the final acceleration speed from 40 to 60 km/h), with an average of 0.078 l. Fig. 1 shows the calculated values  $q_{stop}$  obtained for the Bogdan A09204 bus, which vary from 0.063 litres (at  $n_{stop} = 67$ ) to 0.077 litres (at  $n_{stop} = 4$ ), with an average value of 0.070 litres. The insignificant variation (within 10%) in the values  $q_{syn}$  is explained by the difference in the final acceleration speeds of buses on sections of different lengths and coincides with the results of studies presented in [24].

Currently, the Ministry of Infrastructure of Ukraine recommends calculating fuel and lubricant consumption (FLC) for buses using method [25], which is based on information about the basic linear fuel consumption rate for the vehicle  $H_{BLN}$  and a number of correction factors (8). According to [25], the basic linear fuel consumption rate for Bogdan A09204 buses is  $H_{BLN} = 16.1$  l/100 km; the correction factors that take into account operation in urban conditions  $K_T = 15\%$ ; operation that requires frequent stops  $K_S = 10\%$ ; and the age of the bus  $K_E = 9\%$ . Thus, the standard operating fuel consumption of Bogdan A09204 buses when operating on urban routes is:

$$Q_{FUEL} = 0,01 \cdot H_{BLN} \cdot S \cdot (1 + 0,01 \cdot [K_T + K_S + K_E]) \quad (8)$$

$$Q_{FUEL} = 0,01 \cdot 16,1 \cdot 100 \cdot (1 + 0,01 \cdot [15 + 10 + 9]) = 21,6 \text{ l/100 km.}$$

Fig. 2 shows a joint analysis of the standard operating fuel consumption for Bogdan A09204 buses and the fuel consumption obtained from the simulation results.

Analysis of the information presented in Fig. 2 shows that the fuel consumption of buses operating in normal mode ( $n_{stop} = 26$ ,  $\overline{l_{SPAN}} = 0.51$  km) exceeds the standard values by 36%; and in route taxi mode ( $n_{stop} = 46$ ,  $\overline{l_{SPAN}} = 0.28$  km) by 86%. This fact can be explained, firstly, by the fuel balance structure of the Bogdan A09204 bus (Fig. 3), in which the costs of overcoming inertia forces when stopping account for more than 50%. Secondly, it is due to the distribution of the ratio of the total operating time in gear to the total engine operating time (Fig. 4), which shows that the operation of buses in normal mode and in route taxi mode involves prolonged driving in 1st to 4th gears (from 18.3 to 35.1%), which consume significantly more fuel than when driving in the higher 5th or 6th gears.

Thus, the introduction of express mode on the route will reduce fuel consumption by 30% thanks to a reduction in additional fuel costs, which are equal to  $q_{stop} \cdot n_{stop}$  and a reduction in the duration of driving in 1st to 4th gear.

To test the resulting model (6), experimental studies were conducted (after each trip, when passenger traffic was surveyed, the bus tank was filled to capacity) on fuel consumption on route No. 34, which are marked in Fig. 2 with the symbol ▲. The results obtained show sufficient correspondence between the calculated and experimental values and have a spread of values within 10%.

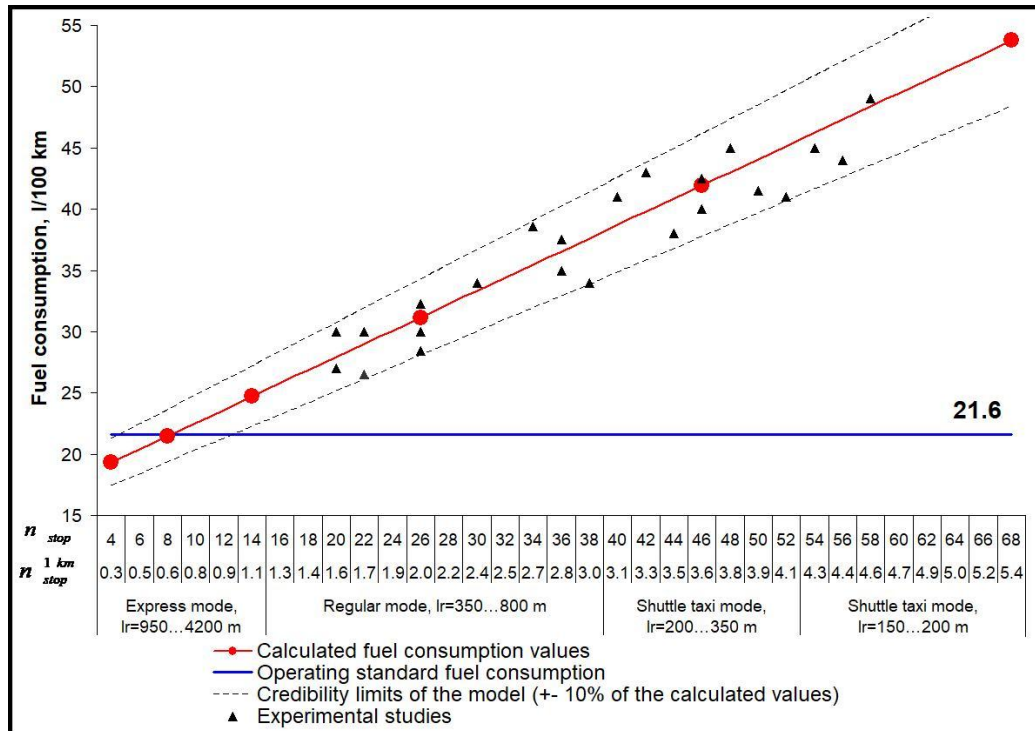

Fig. 2. Joint analysis of operational fuel consumption standards for Bogdan A09204 buses and fuel consumption obtained from modelling results

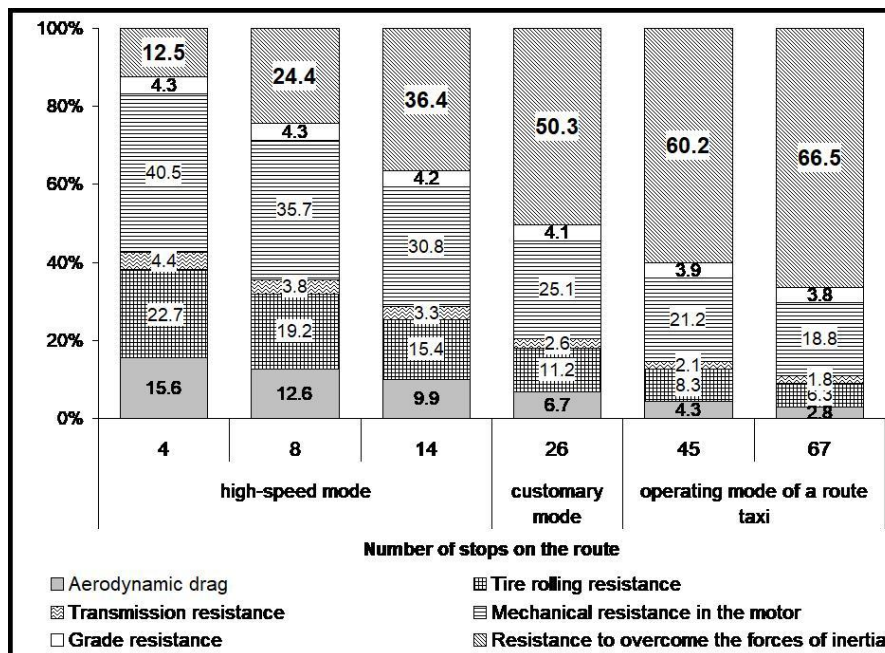

Fig. 3. Fuel balance structure of the Bogdan A09204 bus

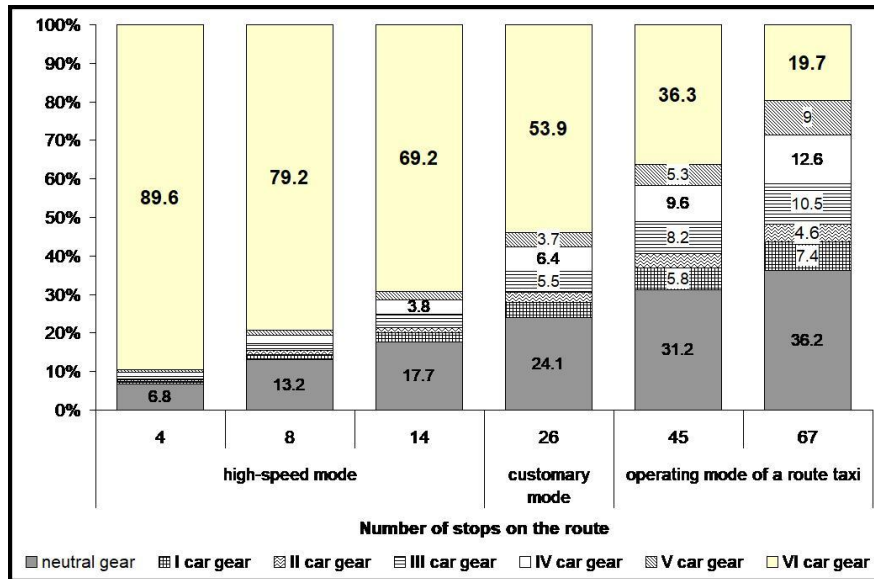

Fig. 4. Distribution of the ratio of total operating time in  $i$ -th gear to the total operating time of the Bogdan A09204 bus engine

It should be noted that the dependence of fuel consumption of Bogdan A09204 buses on the number of stops on route No. 34 (6),  $Q_{l/100\ km}^{Bogdan\ A09204} = 17,144 + 0,538 \cdot n_{stop}$  obtained as a result of modelling, is specific in nature and therefore cannot be used for other routes. Thus, dependence (6) needs to be converted to a form that excludes the link to the length of route No. 34. The number of vehicle stops per 1 km of mileage was chosen as such a generalised indicator:

$$n_{stop}^{1km} = \frac{n_{stop}}{L_R} \quad (9)$$

The dependence of bus fuel consumption as a function of  $n_{stop}^{1km}$  was obtained based on the information presented in Fig. 2 and is as follows:

$$Q_{l/100\ km}^{Bogdan\ A09204} = 17.144 + 6.835 \cdot n_{stop}^{1km} \quad (10)$$

Given the relationship between  $n_{stop}^{1km}$  and the average length of the route  $\overline{l_{SPAN}}$ , it is advisable to present expression (10) in a form that is convenient for assessing the energy efficiency of transport on any route when using different bus operating modes:

$$Q_{l/100\ km}^{Bogdan\ A09204} = 17.144 + 6.835 \cdot \left( \frac{L_R + \overline{l_{SPAN}}}{L_R \cdot \overline{l_{SPAN}}} \right) \quad (11)$$

The reliability of the model obtained (11) is confirmed by the results of studies presented in [26]. According to the results of calculations (which were performed using the method [8]), it was established that the fuel consumption of Bogdan A09204 buses in the urban driving cycle is 29.2 l/100 km. The distribution of stops in a standardised urban driving cycle, according to State Standard 20306, corresponds

to the average length of a route  $\overline{l_{SPAN}} = 550$  m, for which the fuel consumption according to the obtained dependence (11) is 29.9 l/100 km (Fig. 5).

The introduction of an express mode on the route also allows for an increase in bus speed on the route by more than 30% (Table 1, Fig. 5) and, accordingly, their productivity by reducing the duration of the trip. Analysis of the simulation results on other routes where different bus models are operated has established a relationship between the coefficients of models (10) and (11) and the basic linear fuel consumption rate ( $H_{BLN}$ ):

$$Q_{l/100\ km} = H_{BLN} \cdot [1.065 + 0.425 \cdot n_{stop}^{1km}];$$

$$Q_{l/100\ km} = H_{BLN} \cdot \left[ 1.065 + 0.425 \cdot \left( \frac{L_R + \overline{l_{SPAN}}}{L_R \cdot \overline{l_{SPAN}}} \right) \right]. \tag{12}$$

Thus, the established empirical relationships (12) allow for the assessment of the energy efficiency of most bus models depending on the mode of operation on urban bus routes.

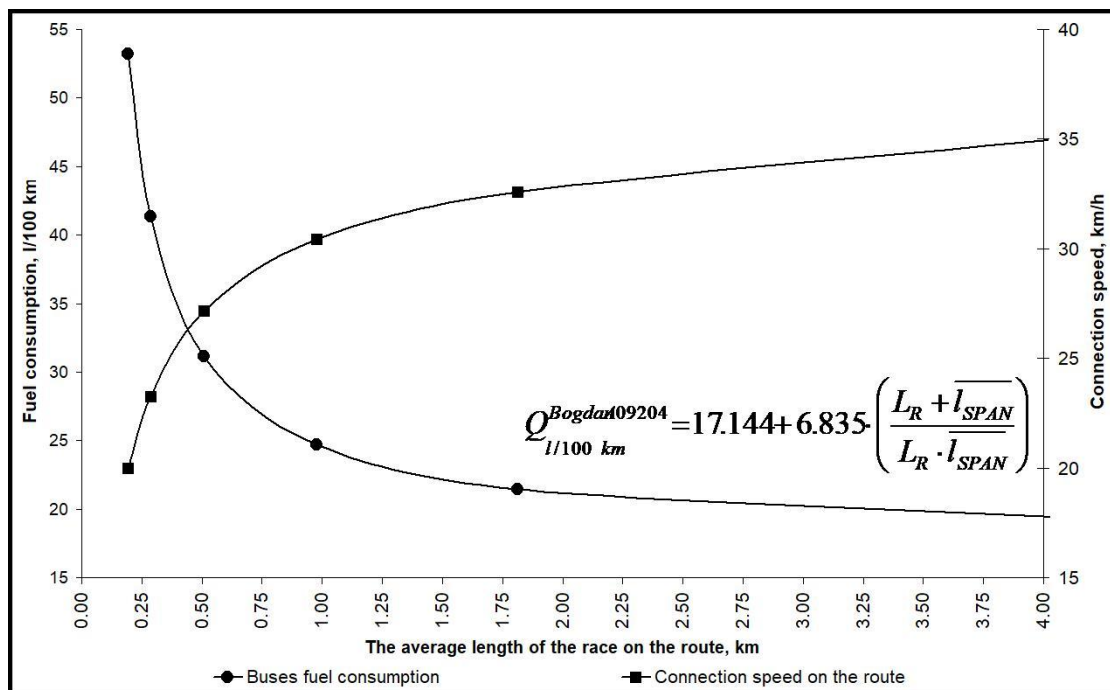

Fig. 5. The impact of the average length of a route on bus fuel consumption and service speed

**Conclusion.** Bus fuel consumption is a major component of transportation costs and significantly affects fare setting, so research related to reducing fuel consumption has economic and social implications. It has been established that one of the main technological indicators affecting bus fuel consumption is the number of stops on the route, since during acceleration and braking, more than 50% of fuel is spent on overcoming inertia.

Currently, the Ministry of Infrastructure of Ukraine recommends calculating fuel and lubricant consumption for buses using a method based on information about the basic linear fuel consumption rate for vehicles. This approach does not take into account all factors affecting fuel consumption by buses when operating in real conditions. It also does not allow carriers to assess the economic benefits of more progressive bus operating modes (e.g., express mode).

Based on the fuel balance equation, a mathematical model was developed that allows investigating the impact of the number of stops on bus fuel consumption, taking into account passenger occupancy.

The results of the modelling (using the example of city bus route No. 34 in Dnipro) allowed us to draw conclusions about the nature of the impact of the number of stops per 1 km of the route and the average length of the journey on bus fuel consumption. It was found that fuel consumption on route No. 34 varies from 18.91 l/100 km (at  $n_{stop} = 4$ ) to 52.95 l/100 km (at  $n_{stop} = 67$ ). In turn, the standard operating fuel consumption of Bogdan A09204 buses, in accordance with the methodology of the Ministry of Infrastructure of Ukraine, is 21.6 l/100 km. Thus, the fuel consumption of buses operating in normal mode ( $n_{stop} = 26$ ,  $\overline{l_{SPAN}} = 0,51$  km) exceeds the standard values by 36%; and in route taxi mode ( $n_{stop} = 45$ ,  $\overline{l_{SPAN}} = 0,29$  km) by 86%. Thus, the introduction of express mode on the route will reduce fuel consumption by 30% and increase the speed of service on the route by more than 25%. An empirical relationship was also obtained, which allows establishing a correlation between these parameters and information about the basic linear fuel consumption rate of vehicles.

## REFERENCES

1. Taran, I.A. & Lytvyn, V.V. (2018). Competitiveness research of city bus routes in the city of Dnepr. *Modern technologies in mechanical engineering and transport*, 1, 123-130. [in Ukrainian].
2. Taran, I. & Lytvyn, V. (2018). Determination of rational parameters for urban bus route with combined operating mode. *Transport Problems*, 13(4), 157-171. <https://doi.org/10.20858/tp.2018.13.4.14>.
3. Kuzkin O. (2018). Optimal planning of trip and round trip cycle time on an urban route. *Technology audit and production reserves*, 2(40), 34-42. <https://doi.org/10.15587/2312-8372.2018.129039>. [in Ukrainian].
4. Buses with High Level of Service. Fundamental characteristics and recommendations for decision-making and research. Results from 35 European cities. (2011). *European cooperation in science and technology*, 180 p.
5. Mesjasz-Lech, A. (2014). Development of public transport in the city – a challenge for urban logistics in terms of sustainable development. *Forum Scientiae Economic*, 2(4), 63-75.
6. de Dios Ortúzar, J., & Willumsen, L. G. (2024). *Modelling transport*. John Wiley & sons.
7. Fornalchyk, E.Yu., Oliskevych, M.S & Mastyash, O.L (2014). Technical operation and reliability of cars: a textbook. *Lviv: Playbill*, 492. [in Ukrainian].
8. Sakhno, V.P. & Savostin-Kosiak, D.O. (2017). Standardization of fuel consumption for city buses with a diesel engine. *Bulletin of the National Transport University*, 3(39), 141-150. [in Ukrainian].
9. Bodnar, M.F & Mytnyk, Y.F. (2012). Experimental estimation of fuel consumption of a small class bus on a suburban route. *Motorway of Ukraine*, 1, 15-19. [in Ukrainian].
10. Volkov, V.P, Gritsuk, I.V & Mateychik, V.P (2018). Features of determining the speed characteristics of the vehicle in operating conditions. *Modern technologies in mechanical engineering and transport*, 2, 38-43. [in Ukrainian].
11. Gorbunov A.P. (2012). Theoretical research on the cost savings on passenger route transport and the prospects for improving performance. *Bulletin of the National Technical University «KhPI»*, 50, 23-28. [in Ukrainian].
12. Grubel, M.G., Bodnar, M.F. & Krainik, Yu.L. (2013). Differentiation of the regulation of linear vitrates of buses and vantages for different minds. *Autoshlyahovik of Ukraine*, 6, 16-21.
13. Dembitsky, V.M., Mazilyuk, P.V. & Pavlyashik, S.M. (2018). Adaptation of the driving cycle to the real minds of the bus cycle. *Scientific notes*, 62, 98-101. [in Ukrainian].
14. Demyanyuk, V.A., Bodnar, M.F. & Krainik, Yu.L. (2012). Typical driving cycles as a basis for prognostic assessment of operational life cycles of buses. *Design, construction and operation of vehicles and trains*, 20, 100-107.
15. Kravchenko, O.P., Krivoshapov, S.I. & Chuiko, S.P. (2019). The improvement of the limitation algorithm of the fuel consumption of the public transport buses equipped with air conditioning units. *Modern technologies in machine-building and transport*, 2, 76-83.
16. Krivoshapov, S.I. & Kashkanov, A.A. (2017). Peculiarities of normalization of the heating of transport vehicles for winter terms of operation. *Bulletin of machine building and transport*, 2, 94-104.
17. Melnichuk, S.V., Chuiko, S.P. & Rafalsky, O.I. (2017). Improvement of fuel efficiency and environmental performance of the Russian bus by optimizing the parameters and driving modes. *Modern technologies in machine-building and transport*, 1, 84-93.
18. Rudzinsky, V.V. (2016). Prior to the selection of technical and operational parameters of buses for work on multiple passenger routes. *Bulletin of Zhytomyr State Technological University*, 1, 138-142.
19. Firsov, O.D. (2019). Improvement of the technological process of the route movement. *Systems and technologies*, 2, 139-160. [in Ukrainian].
20. Chuiko, S.P. (2018). Depending on the complexity of the bus route for the minds of exploitation. *Technical engineering*, (2)82, 160-165. [in Ukrainian]. [https://doi.org/10.26642/tn-2018-2\(82\)-160-165](https://doi.org/10.26642/tn-2018-2(82)-160-165).
21. Yakunin, M.Y. (2017). Analysis of the features of daily driving cycles, which are required for the regulation of the toxicity of the gases used and the assessment of the fuel economy of cars. *Bulletin of NTU «KhPI»*, 14, 98-103. [in Ukrainian].

22. Lytvyn, V.V. (2021). Substantiation of the parameters of express mode of transportation in terms of urban bus routes. PhD thesis. *Kharkiv: HNUUE*, 247. [in Ukrainian].
23. Taha, H.A. (2017). *Operations Research: An Introduction*. 10th. Pearson..
24. Bakulich, O.P. & Dziuba, V.I. (2016). *Organization and regulation of road traffic: handyman*. Kiev: Knowing Ukraine. [in Ukrainian].
25. *Norms of fuel consumption and oil materials for automobile transport*. Kyiv: Ministry of Transport of Ukraine. [in Ukrainian].
26. Sitovsky, O.P., Dembitsky, V.M. & Mazilyuk, P.V. (2018). Evaluation of the economic efficiency of the city buses in the driving cycle reduced to real minds. *Modern technologies in machine-building and transport*, 1(10), 112-116. [in Ukrainian].

**Вадим Литвин<sup>1</sup>, Ірина Клименко<sup>2</sup>**

<sup>1</sup>Доцент, Кафедра управління на транспорті, Національний технічний університет «Дніпровська політехніка», пр. Д. Яворницького, 19, м. Дніпро, 49005, Україна. ORCID: <http://orcid.org/0000-0002-1572-9000>.

<sup>2</sup>Доцент, Кафедра управління на транспорті, Національний технічний університет «Дніпровська політехніка», пр. Д. Яворницького, 19, м. Дніпро, 49005, Україна. ORCID: <https://orcid.org/0000-0002-6263-0951>.

### **Дослідження впливу технологічних параметрів маршруту на витрати палива автобусів в міських умовах**

**Анотація.** Робота присвячена підвищенню ефективності пасажирських перевезень за рахунок дослідження впливу технологічних параметрів маршруту на витрати палива автобусів в міських умовах. Витрати палива автобусів є головною складовою у собівартості перевезень і значною мірою впливають на формування тарифу, тому отримані результати мають також економічний та соціальний ефект. Було встановлено, що одним з основних технологічних показників, які впливають на витрати палива автобусів, є кількість зупиночних пунктів на маршруті, оскільки під час розгону та гальмування понад 50% палива витрачається на подолання сил інерції. На підставі рівняння паливного балансу була розроблена математична модель, яка дозволяє дослідити вплив кількості зупиночних пунктів на витрати палива автобусів з урахуванням наповнення салону пасажирами. Результати проведеного моделювання (на прикладі типового міського автобусного маршруту у м. Дніпро) дозволили зробити висновок, щодо характеру впливу кількості зупинок на 1 км маршруту та середньої довжини перегону на витрати палива автобусів. Також була отримана емпірична залежність, яка дозволяє встановити взаємозв'язок між цим параметрами та відомостями про базову лінійну норму витрати палива транспортних засобів. Представлені результати також дозволяють оцінити технологічні та економічні переваги від впровадження більш продуктивних режимів руху автобусів (наприклад експресного) в міських умовах.

**Ключові слова:** автобусний маршрут, витрати палива, собівартість перевезень, математична модель, паливний баланс, зупиночний пункт, швидкість сполучення, режим руху.

Дата першого надходження статті до видання 14.09.2025

Дата прийняття до друку статті 02.11.2025

UDC 629.4.023

**Olena Sorochynska**<sup>1\*</sup>, **Oleksandr Melnichenko**<sup>2</sup>, **Ivan Kulbovskyi**<sup>3</sup>, **Valentyna Tkachenko**<sup>4</sup>

<sup>1</sup>Associate Professor, Department of Ecology and safety of life, National Transport University, Omelianovycha-Pavlenka str. 1, 01010, Kyiv, Ukraine. ORCID: <http://orcid.org/0000-0003-2477-1275>.

<sup>2</sup>Associate Professor, Department of Manufacturing, Repair and Materials Engineering, National Transport University, Omelianovycha-Pavlenka str. 1, 01010, Kyiv, Ukraine. ORCID: <http://orcid.org/0000-0001-9694-9824>.

<sup>3</sup>Associate Professor, Department of Automation and computer-integrated technologies of transport, National Transport University, Omelianovycha-Pavlenka str. 1, 01010, Kyiv, Ukraine. ORCID: <http://orcid.org/0000-0002-5329-3842>.

<sup>4</sup>Assistant professor, Associate Professor, Department of Transport Law and Logistics, National Transport University, 2, Mykhailo Omelyanovich-Pavlenko str, Kyiv, 01010, Ukraine. ORCID: : <https://orcid.org/0000-0001-5147-0772>.

\*Corresponding author: [sorochynska\\_ol@suite.duit.edu.ua](mailto:sorochynska_ol@suite.duit.edu.ua).

### **System model for the formation of organizational and technical processes for the prevention of emergency situations in transport complex projects**

*The article explores the current challenges related to occupational safety in the transport sector of Ukraine, emphasizing the growing importance of systematic prevention and effective risk management. The study analyzes the main causes of occupational injuries and emergencies, highlighting both technical and organizational shortcomings in existing safety management systems. Particular attention is given to the insufficient implementation of modern risk-oriented approaches and the limited integration of advanced organizational and technical solutions at transport enterprises. The authors substantiate the need to transform traditional occupational safety practices by adopting international standards, such as ISO 45001 and ISO 31010, and by strengthening digitalization processes that enable real-time monitoring of hazards. Based on the results of the analysis, a comprehensive model is proposed for forming organizational and technical prerequisites that aim to reduce injury rates, enhance the efficiency of preventive actions, and improve the reliability of production processes. The model integrates key components such as hazard identification, risk assessment, digital monitoring systems, personnel training, modernization of equipment, and development of a corporate safety culture. It also provides mechanisms for coordinating management decisions, improving regulatory and methodological support, and implementing preventive programs tailored to the specifics of the transport industry. The findings demonstrate that using a systemic approach, supported by digital technologies and analytical tools, significantly strengthens the ability of enterprises to predict and prevent dangerous events. The proposed model can serve as a practical foundation for improving occupational safety management systems, supporting the development of industry programs, and ensuring sustainable and safe functioning of the transport sector.*

**Keywords:** occupational safety; occupational health and safety, management, model, risk, diagnostics, process automation, reliability, transport complex; DSTU ISO standard.

**Introduction.** The modern transport complex is one of the key sectors of the economy, ensuring population mobility, effective functioning of industry and development of foreign economic relations of the state. At the same time, transport activity belongs to the category of increased danger, as it is accompanied by a significant number of potential risks to the life and health of workers, as well as to the safety of production processes. Industrial injuries and accidents remain relevant problems that negatively affect the socio-economic indicators of enterprises and require systematic management at all levels of production organization.

One of the main directions of improving occupational safety in the transport industry is the formation of effective organizational and technical prerequisites that ensure the minimization of risks of personnel injury and the prevention of emergency situations. This requires the implementation of modern methods of assessing occupational risks, improving the occupational safety management system, modernizing technical means and technological processes, as well as developing a corporate safety culture. The relevance of the study is due to the need to improve approaches to the integration of organizational and technical solutions in the field of occupational safety, which will contribute to reducing the level of industrial injuries, increasing the reliability of transport systems and ensuring the sustainable development of enterprises in the industry. The purpose of this article is to identify and substantiate the organizational and technical prerequisites that form the basis for reducing industrial injuries and increasing the level of safety of production activities in the transport complex.

**Analysis of recent research and problem statement.** In the conditions of modern development of the transport complex, the issue of ensuring occupational safety and preventing accidents is becoming one of the key factors in increasing the efficiency of enterprises. Analysis of international and domestic research shows that an integrated approach to safety management, which combines technical, organizational and behavioral aspects, is the most effective for reducing the level of occupational injuries and accidents in transport [1-4]. In this context, the emphasis is on a comprehensive risk assessment, the implementation of occupational safety management systems in accordance with ISO45001 standards and the adaptation of procedures to the specifics of transport subsectors [4-6].

An important area of research is the formation of a safety culture at transport enterprises, which includes organizational measures, personnel training, and motivation to comply with safety rules [7-8]. Along with this, scientists emphasize that the regulatory framework in Ukraine requires further adaptation to modern European standards, and the practical implementation of existing recommendations is often formal in nature, which reduces the effectiveness of preventive measures [9-10].

Despite the existing developments, a number of problems remain: first, there is a lack of comprehensive models that simultaneously take into account technical, organizational and behavioral factors; second, the mechanisms for adapting occupational safety management systems to modern technological challenges, such as automation of transport systems and transportation of dangerous goods, have not been sufficiently studied. Based on this, a relevant research problem is formed: it is necessary to develop and implement a set of organizational and technical prerequisites that will ensure a real reduction in industrial injuries and accidents in the transport complex of Ukraine.

**The purpose and tasks of the study.** The purpose of the study is to determine and substantiate the organizational and technical prerequisites aimed at reducing the level of industrial injuries and preventing accidents in the transport complex. To achieve this goal, the current state of industrial injuries and accidents in the industry was analyzed, the main factors affecting occupational safety were identified, the effectiveness of existing occupational risk management systems was investigated, a set of organizational and technical measures to minimize dangerous industrial situations was substantiated, and practical recommendations were developed to improve the occupational safety management system at transport complex enterprises.

**Materials and methods of research.** Improving the state of industrial safety requires improving the principles of occupational health and safety management. This is determined by modern global trends

in occupational safety, the requirements of relevant international acts. The new principles of industrial safety are based on taking into account various motivational factors, which are determined through analysis, forecasting, personnel management, risk management (industrial, professional), using a process approach, using international practice data and, ultimately, improving the occupational health and safety management system. Among the main issues of improving management, it is important to develop a methodology for analyzing and assessing risks for the purpose of further managing them.

Transport enterprises are enterprises with an increased risk of occupational injuries, occupational diseases and accidents. Currently, many transport enterprises are entering the European market, and therefore, first of all, they need to comply with all international standards, including those on occupational safety. Studying and solving problems related to ensuring healthy and safe conditions in which human work takes place is one of the most important tasks in the development of new technologies and production systems. Researching and identifying possible causes of industrial accidents, occupational diseases, accidents, explosions, fires, developing measures and requirements aimed at eliminating these causes allow creating safe and favorable conditions for human work. Comfortable and safe working conditions are one of the main factors that affect productivity and occupational safety, and the health of employees.

To determine Ukraine's position in the field of occupational safety in the transport sector, a comparative analysis was conducted with EU countries for the period 2020-2024 (Fig. 1).

According to Eurostat and ILO data, the level of occupational injuries in Ukraine remains higher than the EU average, but has a tendency to gradually decrease. This emphasizes the importance of adapting European safety management standards and implementing digital technologies for risk control [11].

Year	Ukraine (injuries/100 thousand works)	EU average	Difference, %
2020	175	120	+45.8
2021	168	118	+42.4
2022	160	115	+39.1
2023	148	110	+34.5
2024	140	107	+30.8

*Fig. 1. Comparison of occupational injury rates (Ukraine vs. EU, 2020-2024)*

The results of the comparative analysis indicate that the issue of occupational safety remains relevant for all types of transport, but it is most acutely manifested in the railway industry. This is due to the specifics of production processes, a high level of technogenic load and the need for constant compliance with safety requirements during the operation of rolling stock and infrastructure. Therefore, further consideration should focus on the specifics of ensuring occupational safety in the railway transport sector.

In modern conditions of railway transport, the issue of occupational health and safety at work is becoming particularly relevant. A high level of occupational injuries not only poses a threat to the life and health of workers, but also negatively affects the overall efficiency of the industry, leads to material losses, downtime and a decrease in the level of trust in the safety management system. Given the complexity of technological processes, traffic intensity, significant energy load and the use of heavy equipment, the formation of an effective accident prevention system is a necessary condition for the sustainable development of railway transport.

In this context, special attention is required to analyze the actual state of occupational injuries and identify key risks inherent in the industry. According to official data, over the past five years, more than 1,147 accidents have been recorded in the railway transport of Ukraine, resulting in injuries to 1,000 workers, 147 of them fatal. Such statistics indicate the presence of systemic problems in the organization of safe working conditions and the need to strengthen control over compliance with occupational safety requirements at all levels of management.

Analyzing the dynamics of indicators for 2020–2024, it can be noted that the situation in the railway industry remains difficult: the severity of the consequences of accidents is almost twice as high as the national average. In particular, in the last two years alone, out of 150 injured workers, 29 people died (Fig. 2). This emphasizes the need to develop and implement a comprehensive program to improve occupational safety, which should include the modernization of technical equipment, improving the personnel training system, strengthening control over hazardous work, and introducing modern information technologies for monitoring working conditions.

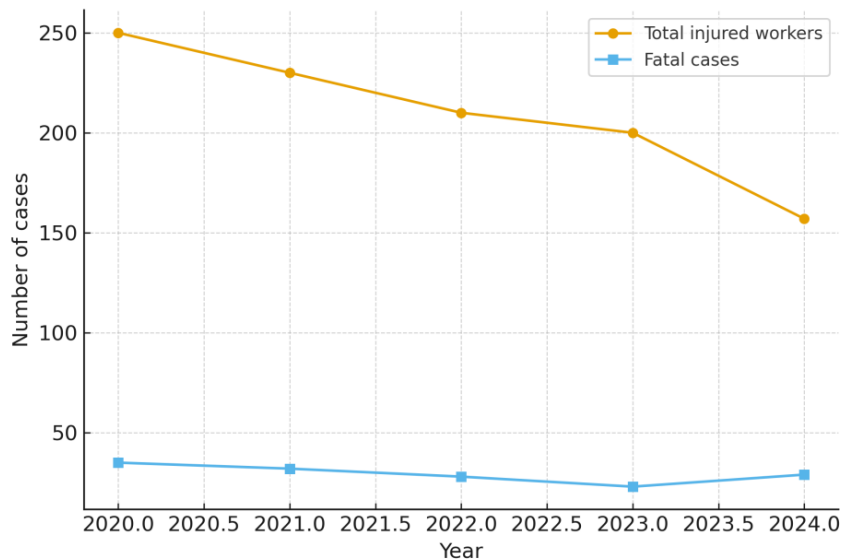
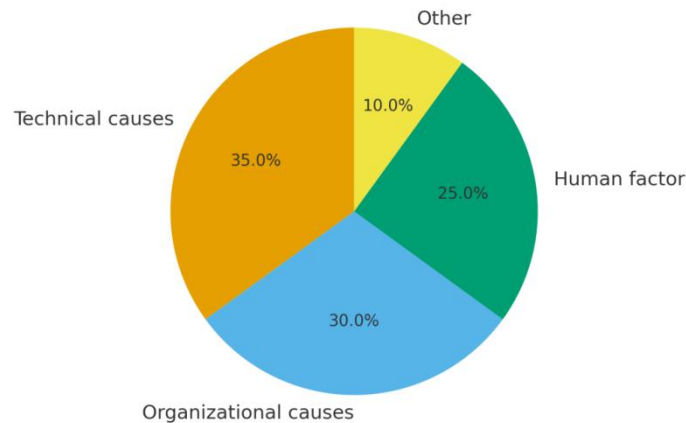

**Fig. 2. Dynamics of Occupational Injuries (2020–2024)**

The analysis of the dynamics of occupational injuries shows that a significant proportion of accidents in the railway industry are related to technical and organizational reasons. This indicates the need to improve the risk management system and implement modern preventive measures.

Creating the prerequisites for reducing the level of occupational injuries at railway transport enterprises requires a comprehensive approach, which includes improving the regulatory framework, upgrading equipment, systematic training of personnel and the use of personal protective equipment. An important role is played by the creation of a safety culture, where each employee is aware of personal responsibility for compliance with occupational safety requirements.

To determine the priority areas of preventive measures, it is important to analyze the main causes of accidents, which allows us to assess the share of technical, organizational and human factors in the overall structure of injuries (Fig. 3.).



**Fig. 3. Distribution of Causes of Occupational Accidents**

Prevention of emergency situations is possible thanks to timely technical maintenance of railway infrastructure, constant monitoring of the technical condition of rolling stock and implementation of automated control systems. An important component of this process is effective communication between all structural divisions of the enterprise, which ensures prompt response to potential threats.

Analysis of the distribution of accident causes shows that a significant proportion of incidents are related to technical and organizational factors, which emphasizes the need for a systemic approach to risk management. In this context, the analysis of previous incidents is of particular importance, which allows identifying typical errors, determining patterns of their occurrence and developing effective preventive measures to prevent recurrence.

Occupational injury is a direct consequence of the realization of hazards, the probability of which is determined by the level of occupational risk. Approaches to assessing the degree of safety of the production environment and the level of occupational risks depend on the scale of the research object - from a separate workplace to an enterprise or industry as a whole.

Depending on the purpose of the research, three main approaches to assessing occupational risks are distinguished:

- ✓ assessment of primary factors of safety of the production environment;
- ✓ assessment of indicators of injury and occupational morbidity;
- ✓ assessment of economic losses associated with accidents and occupational diseases.

In the risk management process, the primary task is:

1. Risk prevention - the process of recognizing the presence of a hazard and determining its characteristics (DSTU ISO 45001:2018) [12];
2. Risk assessment and identification in accordance with the requirements of the ISO 31010:2018 standard [13].

Risk assessment consists of determining the magnitude of risks, analyzing possible consequences and the probability of their occurrence, and making a decision on the acceptability or unacceptability of risks in accordance with ISO 31010:2018. Risk assessment is the most effective preventive measure, which takes into account not only those incidents that occurred in the past, but also hazards that have not yet caused negative consequences. To conduct hazard identification and risk assessment on an ongoing basis, it is necessary to develop a hazard identification and risk assessment methodology focused on incident prevention, which ensures the establishment of priorities, documentation of risks and the use of necessary safety measures. When developing a hazard identification and risk assessment methodology, the scope of the OH&S management system, the nature of possible hazards, the need for detail in the data obtained based on the results of hazard identification and risk assessment, the necessary resources, and other factors important for the enterprise are taken into account.

The results of hazard identification should at least establish:

- hazard (object, situation or action, or a combination thereof);

- location where the hazard occurs (unit, site, etc.);
- type of work, operations during which the hazard occurs;
- employees exposed to the hazard (in particular, their position, profession), as well as all third parties who have access to the location of the hazard.

The results of the risk assessment should establish the magnitude of the identified risk, in particular, unacceptable risks. This information is used when determining the priority of implementing safety measures.

An integrated approach based on international standards, such as ISO 45001:2018 and ISO 31010:2018, allows not only to identify potential hazards, but also to implement effective preventive measures in a timely manner. The formation of a safety culture, the active participation of employees in the risk identification processes, the use of modern analysis methods and monitoring the technical condition of the infrastructure - all these are integral components of reducing the level of injuries. The implementation of the proposed recommendations will not only save the lives and health of employees, but also increase the overall efficiency and reliability of the industry.

Occupational risk assessment is one of the key elements of the occupational health and safety management system at transport complex enterprises. In accordance with the requirements of the international standards ISO 31000:2018 “Risk management – Guidelines” and ISO 45001:2018 “Occupational health and safety management systems – Requirements with guidance for use”, the risk assessment process should ensure the identification of hazardous factors, analysis of their consequences and determination of the probability of potentially dangerous events.

In modern transport safety management practice, a number of methods are used that differ in depth of study, quantitative and qualitative indicators, and complexity of implementation. Among the most common approaches, one can single out HAZOP analysis (Hazard and Operability Study), which is used to systematically identify possible deviations in technological processes and determine their consequences for the safety of workers and equipment. The FMEA (Failure Mode and Effects Analysis) method is aimed at assessing possible failures of system elements and their impact on the overall level of safety. Its advantage is the possibility of early identification of critical components of a vehicle or technological process, which allows for timely prevention of emergency situations [14,15].

To assess the effectiveness of implementing a risk-based occupational safety management system, the authors conducted an analysis of the dynamics of the main indicators of occupational safety at transport complex enterprises.

The results are presented in Table 1, which compares the frequency and severity of injuries before and after the implementation of the risk management system. As can be seen from the table, after implementing the OHSMS measures, the injury frequency rate decreased by 35.4%, and the severity rate decreased by 34.3%. There was also a 39% reduction in the number of days of downtime due to accidents, which indicates an increase in the effectiveness of preventive actions and safety discipline among employees.

*Table 1. Comparison of injury rates before and after implementation of the risk-based OHS system*

<b>Indicator</b>	<b>Before implementation</b>	<b>After implementation</b>	<b>Change, %</b>	<b>Result</b>
Injury frequency rate	4.8	3.1	–35.4	Fewer incidents per 1 million hours
Injury severity coefficient	0.32	0.21	–34.3	Reduction of lost working time
Number of days of downtime due to accidents, days	410	250	–39.0	Process optimization

Level of implementation of preventive measures, %	72	94	+30.6	Increased security discipline
---------------------------------------------------	----	----	-------	-------------------------------

Risk matrices are also used to analyze working conditions and production processes at transport enterprises, which combine a qualitative assessment of the probability of an event and the severity of its consequences, allowing to determine the priorities of preventive measures. The use of multifactor risk matrices during the analysis of road accidents allows to establish the main patterns and critical risk zones [14]. In addition, the “5 Whys” method is actively used to determine the root causes of dangerous events, especially in cases of organizational and behavioral errors of personnel.

An important component of modern methods is their integration into information and analytical security management systems, which allows for real-time risk monitoring. As noted, the introduction of digital technologies and data collection systems within the framework of the SSM ensures increased efficiency of management decisions and the formation of an effective feedback system regarding incidents and potential hazards [16].

For a comprehensive assessment of the safety level, a safety index (Safety Performance Index) was used, which integrates key parameters: the frequency and severity of injuries, as well as the level of implementation of preventive measures. The calculation was carried out according to formula 1, which takes into account the weighting factors of the influence of each indicator.

$$SPI = w_1 \cdot F + w_2 \cdot S + w_3 \cdot P, \quad (1)$$

where  $SPI$  – Safety Performance Index;

$F$  – Injury Frequency Rate, which characterizes the number of accidents per 1000 employees;

$S$  – Injury Severity Rate, which is determined by the ratio of lost work capacity to the total working time;

$P$  – Preventive Measures Index, which reflects the level of implementation of planned actions to improve occupational safety (in percentages or points);

$w_1, w_2, w_3$  – weighting factors, which characterize the relative importance of each indicator in the overall assessment (provided that  $w_1 + w_2 + w_3 = 1$ ).

The safety index allows for an integrated assessment of the state of occupational safety at an enterprise or in the industry as a whole, taking into account not only the consequences of accidents, but also the effectiveness of preventive actions. A high SPI value indicates a reduction in production risks and an increase in the level of organizational safety, while a low one indicates the need to strengthen preventive work and improve the risk management system.

The results confirmed that increasing the level of digitalization of the system (through the use of IoT, Big Data and analytical modules for risk monitoring) is positively correlated with a decrease in the number of incidents. This demonstrates the feasibility of moving to a digital model of occupational safety management. (Fig. 4).

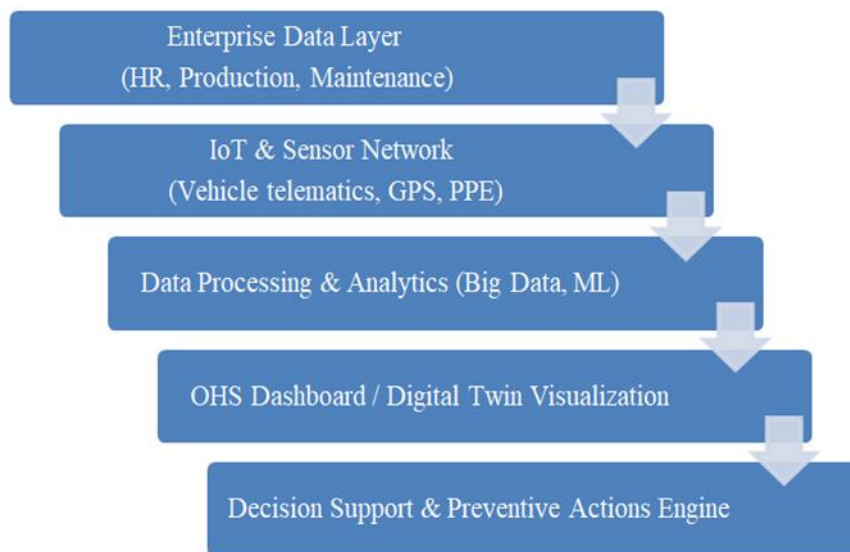

**Fig. 4. Architecture of the digital OHS management system for the transport sector**

Therefore, the use of comprehensive risk assessment methods in the transport complex allows to increase the level of control over hazardous factors, optimize the processes of planning preventive measures and create a basis for the formation of organizational and technical prerequisites aimed at minimizing occupational injuries and preventing emergency situations. This approach provides a systematic combination of analytical, managerial and technical tools that increase the stability of the transport infrastructure.

The results of the comparative analysis confirm the need for further improvement of the occupational safety management system in the transport sector of Ukraine. Reducing the level of occupational injuries is possible only if a comprehensive approach is implemented, which covers organizational, technical, information-analytical and socio-psychological aspects.

Further improvement of occupational safety is achieved through the implementation of an occupational health and safety management system (OHSMS) in accordance with the international standard ISO 45001:2018. It ensures consistency in the processes of hazard identification, risk assessment, planning and implementation of preventive measures. An important component of this system is the development of incident prevention programs (Near Miss Programs), which allow to identify potentially dangerous situations before accidents occur, which significantly increases the level of proactive safety management [17].

Technical modernization of transport enterprises should be based on the implementation of intelligent transport systems (ITS), online monitoring tools based on IoT (Internet of Things) and digital twins of transport processes. Such technologies make it possible to monitor safety parameters in real time, predict risks and promptly make management decisions to prevent accidents [18].

An important aspect of ensuring occupational safety is also ergonomic workplace design, aimed at optimizing the physical and psycho-emotional stress of employees. Improving the microclimate, lighting, and reducing noise and vibration levels help reduce operator fatigue and errors, increasing the overall efficiency of production processes.

To improve the quality of risk analysis, it is advisable to use modern management techniques - FMEA (Failure Mode and Effects Analysis), HAZOP (Hazard and Operability Study), Bow-Tie Analysis, which allow you to systematically structure information about the probability and consequences of events, identify critical elements of processes and set priorities for the implementation of preventive measures.

The use of these approaches contributes to the transition to a proactive model of occupational safety management, focused not only on response, but primarily on preventing accidents and minimizing the

consequences of dangerous events. This is one of the key prerequisites for the sustainable development of the transport industry.

To achieve a high level of occupational safety in the transport sector, it is necessary not only to analyze existing risks, but also to systematically create conditions for their reduction. In view of this, the study proposes a conceptual model for the formation of organizational and technical prerequisites for reducing occupational injuries and preventing accidents. It reflects the relationship between the initial risk factors, safety management processes (assessment, prevention, technical modernization, development of a safety culture) and the expected results - reducing the level of injuries, increasing the reliability of production processes and ensuring the sustainable functioning of transport enterprises.

The proposed model (Fig. 5) demonstrates the relationship between input risk factors, digitalized management processes (risk identification, assessment, monitoring and control) and results in the form of increased occupational safety and reliability of transport systems. Its use ensures the integration of organizational, technical and digital solutions into a single occupational safety management system focused on the prevention of dangerous events and increasing the efficiency of the transport complex.

In the current conditions of digital transformation of the transport industry, the creation of unified information and analytical systems for occupational safety management that integrate data from various sources - sensors, video surveillance, GPS trackers, technical maintenance databases and personnel training is of particular importance. The use of Big Data analytics and machine learning algorithms allows not only to record incidents in real time, but also to predict their probability, increasing the effectiveness of preventive measures and ensuring timely management decisions [19].

Throughout 2025, JSC Ukrzaliznytsia is carrying out work on automating processes in the field of labor protection, aimed at increasing the efficiency of collecting and analyzing performance indicators. The main areas of digitalization include:

1. Modernization of the automated system "Industrial Safety" by integrating the subsystem "Highly Hazardous Equipment";
2. Implementation of the functionality "Industrial Injuries" as part of the Unified Automated Personnel Management System of the IT-Enterprise complex;
3. Creation of the module "Labor Protection Training", which provides electronic accounting, control and verification of the completion of briefings and knowledge tests;
4. Development of the module "Personal Protective Equipment" in the supply chain management system, which allows optimizing logistics and accounting for employee protective equipment.

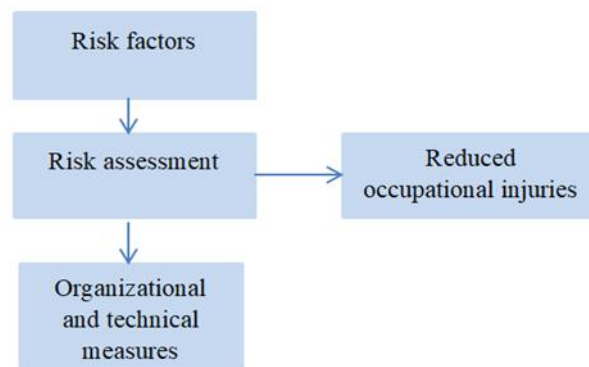

**Fig. 5. Conceptual Model of Organizational and Technical Prerequisites for Reducing Occupational Injuries and Preventing Emergencies in the Transport Sector**

The integration of these solutions forms a single digital ecosystem of occupational safety management, which provides automated collection, processing and visualization of data on risks and incidents. This approach contributes to making informed management decisions, increases the

transparency of processes and strengthens preventive mechanisms at all levels of the production organization.

To verify the practical effectiveness of the developed system, testing was carried out at the transport enterprise. Based on the results obtained, a phased algorithm for implementing an organizational and technical model of occupational safety management was proposed (*Table 2*).

Each stage includes specific actions – from the initial diagnostics of the state of occupational health and safety to digital monitoring and assessment of the system maturity according to the OHS Maturity Model. This approach ensures a gradual increase in the level of management safety culture, systematic improvement of processes and minimization of production risks

*Table 2. Stages of implementing the organizational and technical safety model*

Stage	Basic actions	Expected result
1	Initial diagnostics of occupational safety status	Identifying key risks and weaknesses
2	Development of a preventive action plan	Establishing priorities and prevention strategies
3	Implementation of digital modules (monitoring, training, PPE accounting)	Automation of data collection and control
4	Digital monitoring and system maturity assessment	Determining the level of management efficiency and process improvement

Thus, the integration of the conceptual model of organizational and technical prerequisites, digital technologies and practical implementation mechanisms allows for a systematic and proactive approach to occupational safety management in the transport sector. The use of unified information and analytical platforms, automated monitoring modules and digital twins ensures timely identification of potential risks and increases the effectiveness of preventive measures. The phased implementation of the model, taking into account the maturity of the management system, allows for a gradual increase in the safety culture at enterprises and a reduction in the level of occupational injuries. Such an integrated approach creates a solid foundation for the sustainable development of the transport industry, ensures the reliability and safety of production processes and is the basis for formulating final recommendations and strategies for improving the occupational safety management system.

**Conclusions.** The study confirmed the relevance of the problem of ensuring occupational safety and preventing accidents in the transport complex of Ukraine. Analysis of the current state of industrial injuries showed that the most common causes of accidents are technical and organizational factors, which indicates the presence of systemic deficiencies in the existing safety management systems. Comparative analysis of injury rates in Ukraine and EU countries confirmed the need to adapt international standards, in particular ISO 45001:2018 and ISO 31010:2018, to the specifics of the Ukrainian transport sector and the introduction of modern digital technologies for risk monitoring.

The paper proposes a model for the formation of organizational and technical prerequisites for reducing the level of industrial injuries and preventing emergencies, based on the principles of systematicity, prevention and integration with quality and risk management processes. The model provides for a comprehensive approach that includes:

- identification and assessment of risks, including the use of HAZOP, FMEA and "5 Whys" analysis methods;
- modernization of technical equipment of enterprises and the implementation of digital monitoring systems (IoT, Big Data, digital twins);
- development of a corporate safety culture, personnel training and monitoring of the implementation of measures;
- formation of a single information and analytical platform for automated collection, processing and visualization of data on risks and incidents.

The results of the practical implementation of the model at a transport enterprise showed a significant reduction in the frequency of injuries (by 35.4%), the severity of consequences (by 34.3%) and the number of days of downtime due to accidents (by 39%), which indicates the effectiveness of the proposed approach and its ability to increase the level of safety and reliability of production processes.

Thus, the integration of organizational and technical solutions, digital technologies and practical implementation mechanisms provides a systematic and proactive approach to occupational safety management. The use of unified information and analytical platforms and automated monitoring modules allows for timely identification of potential risks, increases the effectiveness of preventive measures and forms the basis for the sustainable development of the transport industry. The proposed conceptual model can serve as a methodological basis for the development of strategies and programs to improve occupational safety at enterprises in the transport sector of Ukraine.

## REFERENCES

1. Pustulha, S., Samchuk, V., Prydiuk, V., Pasichnyk, O., & Shymchuk, O. (2024). Improving safety criteria for transporting hazardous goods by road through optimizing the geometric parameters of their stowage. *Eastern European Journal of Enterprise Technologies*, 3(129), 74–84. <https://doi.org/10.15587/1729-4061.2024.307235>.
2. Lyashuk, O., Mironov, D., & Martyniuk, V. (2024). Risk analysis of road traffic accidents in Ukraine. *Transport*, 39(4), 350–359. <https://doi.org/10.3846/transport.2024.23190>.
3. Makarova, I., Yakupova, G., Buyvol, P., Abashev, A., & Mukhametdinov, E. (2022). Risk Management Methodology for Transport Infrastructure Security. *Infrastructures*, 7(6), 81. <https://doi.org/10.3390/infrastructures7060081>.
4. Russo, F., & Comi, A. (2017). From the analysis of European accident data to safety assessment for planning: the role of goods vehicles in urban area. *European Transport Research Review*, 9, 9. <https://doi.org/10.1007/s12544-017-0225-0>.
5. Sorochnytska, O., Melnichenko, O., Kulbovskiy, I., & Derehuz, I. (2025). Implementation of the occupational health and safety management system model according to DSTU ISO 45001:2018: challenges and opportunities for transport enterprises. *Transport Systems and Technologies*, 45. <https://doi.org/10.32703/2617-9040-2025-45-8>.
6. Protasenko, O., & Mykhailova, Ye. (2024). Implementation of European standards for occupational safety and health in Ukraine. *Municipal Economy of Cities*, 4, 185–204. <https://doi.org/10.33042/2522-1809-2024-4-185-204-210>.
7. Bal, O. (2023). Formation and management of safety culture in the railway industry: best practices and strategies. *Transport Systems and Technologies*, 42(6). <https://doi.org/10.32703/2617-9059-2023-42-6>.
8. Chabanov, A. (2023). Features of regulatory and legal regulation of transport safety in Ukraine: realities and perspectives. *Public Management*, 3(36). [https://doi.org/10.32689/2617-2224-2023-3\(36\)-8](https://doi.org/10.32689/2617-2224-2023-3(36)-8).
9. Shatrava, S. O., Denyshchuk, D. Y., & Pohorilets, O. V. (2023). State policy in the field of ensuring road safety in Ukraine through the prism of regulatory initiatives: analysis and prospects for implementation. *Law and Safety*, 89(2), 54–65. <https://doi.org/10.32631/pb.2023.2.05>.
10. Vasylieva, O. (2024). Regulatory and legal support of the functioning of public transport in Ukraine: realities and prospects. *Public Administration and Regional Development*, 1. <https://doi.org/10.34132/pard2024.23.05>.
11. Eurostat. (2024). *Accidents at work: Statistics by economic activity*. Retrieved November 13, 2025, from <https://ec.europa.eu/eurostat/statistics-explained/SEPDF/cache/70752.pdf>.
12. ISO 31000:2018. Risk management – Guidelines. Geneva: International Organization for Standardization, 2018. 20 p.
13. ISO 45001:2018. Occupational health and safety management systems – Requirements with guidance for use. Geneva: International Organization for Standardization, 2018. 48 p.
14. Tsopa, V., Cheberichko, S., Yavorska, A., & Chernysh, V. (2023). Occupational safety and health management in transport companies: organizational and technical aspects. *Environmental Safety and Sustainable Development*, 5(2), 56–67. <https://doi.org/10.32347/2411-4049.2023.2.85-99>.
15. Stasiak-Betlejewska, R. (2022). Occupational risk management in the transport company. *System Safety: Human-Technical Facility-Environment*, 4(1), 135-149. <https://doi.org/10.2478/czoto-2022-0014>.
16. Jiang, L., Zhang, J., & Wong, Y. D. (2024). *Digital technology in occupational health of manufacturing industries: a systematic literature review*. *Discovery in Applied Sciences*, 6, 631. <https://doi.org/10.1007/s42452-024-06349-4>.
17. Agnusdei, G. P., Elia, V., & Gnoni, M. G. (2021). *Is Digital Twin Technology Supporting Safety Management? A Bibliometric and Systematic Review*. *Applied Sciences*, 11(6), 2767. <https://doi.org/10.3390/app11062767>.
18. Agnusdei, G. P., Elia, V., & Gnoni, M. G. (2021). *Is Digital Twin Technology Supporting Safety Management? A Bibliometric and Systematic Review*. *Applied Sciences*, 11(6), 2767. <https://doi.org/10.3390/app11062767>.
19. Wang, B. (2021). *Big data in safety management: An overview*. *Safety Science*, 148, 105671. <https://doi.org/10.1016/j.ssci.2022.105671>.

**Олена Сорочинська<sup>1</sup>, Олександр Мельниченко<sup>2</sup>, Іван Кульбовський<sup>3</sup>, Валентина Ткаченко<sup>4</sup>**

<sup>1</sup>Доцент, кафедра «Екологія та безпека життєдіяльності», Національний транспортний університет, вул. Михайла Омеляновича-Павленка, 2, 01010, м. Київ, Україна. ORCID: <http://orcid.org/0000-0003-2477-1275>.

<sup>2</sup>Професор, кафедра «Виробництво, ремонт та матеріалознавство», Національний транспортний університет, вул. Михайла Омеляновича-Павленка, 2, 01010, м. Київ, Україна. ORCID: <http://orcid.org/0000-0001-9694-9824>.

<sup>3</sup>Доцент, кафедра «Автоматизація та комп'ютерно-інтегровані технології транспорту», Національний транспортний університет, вул. Михайла Омеляновича-Павленка, 2, 01010, м. Київ, Україна. ORCID: <http://orcid.org/0000-0002-5329-3842>.

<sup>4</sup>Доцент, кафедра транспортного права та логістики, Національний транспортний університет, вул. Михайла Омеляновича-Павленка, 2, 01010, м. Київ, Україна. ORCID: <https://orcid.org/0000-0001-5147-0772>.

### **Системна модель формування організаційно-технічних процесів з запобігання аварійних ситуацій в проєктах транспортного комплексу**

***Анотація.** У статті досліджено актуальні проблеми забезпечення безпеки праці на підприємствах транспортного комплексу України, що зумовлені високим рівнем професійних ризиків, техногенним навантаженням та недоліками в організації виробничих процесів. Проаналізовано основні причини виникнення виробничого травматизму й аварійних ситуацій, серед яких технічні несправності, порушення технологічних регламентів, недостатній рівень контролю та недосконалість систем управління охороною праці. Наголошено на необхідності переходу до ризик-орієнтованого підходу, який ґрунтується на системній ідентифікації небезпек, кількісній та якісній оцінці ризиків і впровадженні превентивних заходів. Запропоновано модель формування організаційно-технічних передумов для зниження рівня виробничого травматизму та запобігання аварійним ситуаціям у транспортному комплексі. Модель включає інтеграцію сучасних організаційних рішень, технічної модернізації, цифрових технологій моніторингу, удосконалення системи навчання персоналу та розвитку корпоративної культури безпеки. Додатково підкреслено значення впровадження цифрових інструментів, таких як автоматизовані системи контролю, моніторинг у реальному часі та аналітичні платформи для оцінки ризиків, що забезпечують оперативне реагування на потенційно небезпечні ситуації. Акцентовано увагу на важливості застосування міжнародних стандартів, зокрема ДСТУ ISO 45001 та ISO 31010, що забезпечують послідовність, прозорість і ефективність процесів управління ризиками. Обґрунтовано, що використання комплексного підходу до управління охороною праці, який поєднує аналітичні, технічні та організаційні інструменти, сприяє своєчасній ідентифікації небезпек, зменшенню кількості інцидентів і підвищенню надійності виробничих процесів. Представлені у статті результати можуть бути використані для підвищення ефективності систем управління охороною праці, удосконалення нормативно-методичного забезпечення та розроблення галузевих програм із запобігання аварійності у транспортному комплексі.*

**Ключові слова:** безпека праці; охорона праці, управління, модель, ризик, діагностика, автоматизація процесу, надійність, транспортний комплекс; стандарт ДСТУ ISO.

*Дата першого надходження статті до видання 07.10.2025*

*Дата прийняття до друку статті 19.11.2025*

UDC 621.33: 629.4

**Ievgen Riabov<sup>1\*</sup>, Liliia Overianova<sup>2</sup>, Kostiantyn Ivanov<sup>3</sup>, Iryna Bilokon<sup>4</sup>, Anton Zhukov<sup>5</sup>**

<sup>1</sup> Assistant professor, Department of Electric Transport and Locomotive Engineering, National Technical University «Kharkiv Polytechnic Institute», Kyrpychova str. 2, Kharkiv, 61002, Ukraine  
ORCID: <https://orcid.org/0000-0003-0753-514X>.

<sup>2</sup> Assistant professor, Department of Electric Transport and Locomotive Engineering, National Technical University «Kharkiv Polytechnic Institute», Kyrpychova str. 2, Kharkiv, 61002, Ukraine  
ORCID: <https://orcid.org/0000-0002-4827-572X>.

<sup>3</sup> Postgraduate student, Department of Electric Transport and Locomotive Engineering, National Technical University «Kharkiv Polytechnic Institute», Kyrpychova str. 2, Kharkiv, 61002, Ukraine  
ORCID: <https://orcid.org/0009-0000-3000-8191>.

<sup>4</sup> Director, Kremenchuk Applied College of Transport Infrastructure and Technology, 14, Yuri Ruf str., Kremenchuk, Poltava Region, 39600, Ukraine. ORCID: <https://orcid.org/0000-0002-4675-3994>.

<sup>5</sup> LLC «Kharkiv Electric Machine-Building Plant», Avenue of Heroes of Kharkiv, 199, Kharkiv, 61037, Ukraine ORCID: <https://orcid.org/0009-0001-5229-1685>

\*Corresponding author: [riabov.ievgen@gmail.com](mailto:riabov.ievgen@gmail.com).

## **Development of a Hybrid Traction System for a Suburban Multiple Electric Train with Dual Power Supply**

*This paper examines and analyses the design options for traction systems of modern electric rolling stock. Traction systems based on traditional circuit design solutions are reviewed and discussed. A review of traction systems with converters using medium-frequency transformers is provided. The use of such transformers reduces the weight of electrical equipment, requires less installation space, and increases the energy efficiency of electric rolling stock. It is shown that a priority approach is to use a hybrid traction system based on traditional circuit solutions, as its components exhibit high reliability. Several variants of hybrid traction systems for a dual-supply suburban electric train are proposed. The study demonstrates the feasibility of stabilising the intermediate circuit voltage to ensure autonomous energy exchange between the energy storage system and the traction drive. The operation of the circuits is described, and it is shown that when the intermediate DC-link voltage does not exceed 1000 V, standard industrial solutions can be used in the energy storage system. The proposed hybrid traction systems can be implemented in the modernisation or development of new electric multiple units and may also be used in other types of rail vehicles.*

**Keywords:** *electric rolling stock, energy efficiency, hybrid traction system, traction electric drive, energy storage device, traction converter, traction transformer, traction asynchronous motor.*

**Introduction.** Suburban railway transport plays a crucial role in the functioning of large urban agglomerations. By providing daily commuting for work and social purposes, suburban rail transport contributes to the integration of suburban areas into the socio-economic space of cities [1]. According to [2], more than 400 suburban train services operate within metropolitan areas of major regional centres and the capital. However, despite the significant share of suburban transport provided by railways, a declining trend in passenger numbers has been observed. This is linked to several factors affecting the efficiency and competitiveness of suburban rail transport. Among them is the high degree of rolling stock wear, which influences both the technical performance during operation and passenger comfort. In recent years, the rolling stock used for suburban services has been gradually renewed, primarily to

improve passenger comfort, enhance working conditions for locomotive crews, and upgrade safety systems [3]. Nevertheless, the modernised electric multiple units still employ serial traction systems developed more than 50 years ago. Consequently, these trains exhibit increased consumption of fuel and energy resources, which, in conditions of rising energy costs, leads to higher operating expenses for suburban services that are already subsidised [4].

Given the ageing of rolling stock where wear is estimated at 85% and outdated technical solutions that increase maintenance and energy costs, as well as reduce reliability, the renewal of rolling stock or its traction systems has become an urgent necessity. The first approach complete replacement provides the best technical performance and comfort levels but requires substantial capital investment for acquisition, maintenance, and servicing. A more economical alternative is the modernisation of existing rolling stock [5]. Regardless of the chosen approach, the traction system must ensure high energy efficiency, as this directly reduces the consumption and cost of fuel and energy resources.

Almost all suburban transport services in Ukrainian urban agglomerations operate on electrified lines. For direct current sections, electric trains of the series ER2, ER2R, ER2T, ED2T, and EPL2T are used. On alternating current sections, trains of the series ER9, ER9M, ER9E, and EPL9T operate. The most recent models EPL2T and EPL9T were manufactured by PJSC Luhanskteplovoz in the early 2000s. However, their traction equipment is largely inherited from older models, retaining the same shortcomings associated with low energy efficiency. A major disadvantage is the lack of regenerative braking in AC electric trains and most DC ones, despite regeneration being a key technology for energy saving in electric traction systems [6, 7]. However, full utilisation of regenerative energy is only possible when the process is autonomous [8], which can be achieved through the use of onboard energy storage systems. Therefore, the development of a traction system incorporating energy storage for suburban electric trains is a relevant and pressing task.

**Analysis of recent research and problem statement.** Improvement of electric multiple unit rolling stock is essential for the stable operation of railway transport. Ukrainian researchers have conducted studies aimed at enhancing the traction systems of serial electric trains [9], developing innovative traction systems [10–12], and creating electrical equipment for various types of electric rolling stock [13, 14]. The use of energy storage devices on electric rolling stock has been explored in [15–17]. Certain aspects related to the integration of energy storage systems into rolling stock have been studied in [18–20] and other publications. Unfortunately, most of these works remain theoretical.

Abroad, the technology of onboard energy storage for rail transport has reached the stage of practical implementation. The MITRAC Energy Saver system, developed by Bombardier Transportation, enables energy savings of up to 30% when applied to tram cars. It reduces voltage fluctuations at the pantograph, decreases losses in the traction network, and allows autonomous operation on non-electrified sections [21]. Reference [22] presents test results for the Series EV-E301 train, where an onboard energy storage system powers the train while running on non-electrified tracks. The onboard storage accumulates energy during braking, thus reducing the energy required for recharging from the overhead line or charging station at the terminus.

Experimental tests of the Hi-tram tram car demonstrated the potential to recover up to 41% of the energy consumed for traction [23]. In [24], the results of experimental studies of the BEC-819 electric train are presented; this train was modernised with an onboard energy storage system, which enabled operation on non-electrified lines and accumulation of energy during electrodynamic braking for recharging.

Advances in chemical energy storage technologies have made it possible to develop rolling stock powered by traction batteries. Such vehicles can operate autonomously on non-electrified lines for up to 100 km or more. Examples include Bombardier Talent 3 [25], FLIRT Akku [26], Siemens Mireo Plus B [27], and others. These trains are equipped with high-capacity traction batteries that can be charged from the overhead line, at terminal stations, or through regenerative braking.

A similar class of vehicles includes tram systems operating without overhead contact lines [28]. Such rolling stock uses compact energy storage units that recharge at stops from contactless power sources. Notably, energy storage systems are also used in multiple units with triple-mode power supply [29].

The use of onboard energy storage systems in electric rolling stock is now widespread and serves the following purposes:

1. Accumulation of energy during electrodynamic braking with subsequent use to power onboard systems;
2. Power supply to rolling stock systems during movement along non-electrified sections.

The type and parameters of an onboard energy storage system depend on its intended function [17, 30].

Thus, the analysis confirms the feasibility and efficiency of integrating energy storage systems into electric rolling stock.

To ensure the effective use of onboard storage on Ukrainian multiple units, several operational factors must be considered.

Firstly, Ukrainian railways employ two traction power supply systems:

- Direct current with a nominal voltage of 3 kV;
- Alternating current with a nominal voltage of 25 kV at an industrial frequency of 50 Hz.

The pantograph voltage varies within 2.2–4.0 kV for DC lines and 19–29 kV for AC lines. Therefore, it is rational to unify the traction equipment that does not directly interact with the contact network.

Secondly, since some routes pass through sections electrified under both systems, it is advisable that input equipment can operate with either DC or AC supply.

Thirdly, the traction system must include an onboard energy storage device. As mentioned earlier, for the energy storage system to function effectively, its power flow processes must be autonomous and unaffected by the traction network.

Hence, the requirements outlined above must be taken into account in designing traction systems for multiple-unit rolling stock equipped with onboard energy storage systems.

**Purpose and Objectives of the Study.** The purpose of this study is to develop and analyse a hybrid traction system for a suburban electric train, taking into account operational conditions and factors.

The main objectives of the research are as follows:

- To analyse existing circuit design solutions used in the traction systems of electric rolling stock;
- To develop a schematic design for a hybrid traction system applicable to a suburban electric train.

**Materials and Methods of the Study.** The multiple-unit rolling stock currently operated by Ukrzaliznytsia JSC for suburban passenger services is designed to work exclusively with a single traction power supply system. Dual-system trains include Hyundai Rotem HRCS2, Škoda EJ 675, and EKr-1, which are primarily used for Intercity services. Analysis of the technical documentation for these trains indicates that they use the most common traction circuit configuration applied in dual-system rolling stock (Fig. 1a).

In the circuit shown in Fig. 1a, the traction inverter is connected directly to the 3 kV DC network, which necessitates the use of 65-class IGBT transistors [32]. The input four-quadrant converter (4QS) also requires transistors of the same class. When operating from a 25 kV, 50 Hz AC network, a traction transformer and a 4QS converter are used. The main advantages of this circuit are its simplicity and high energy performance. However, a significant drawback is the inability to stabilise the intermediate DC-link voltage when powered from a DC supply. This limitation complicates the integration of an energy storage system, as fluctuations in the intermediate voltage may disrupt energy exchange between the traction drive and the storage unit.

To eliminate voltage fluctuations in the intermediate circuit, chopper-based configurations are required (Fig. 1b and Fig. 1c).

In the circuit shown in Fig. 1b, 65-class IGBTs are used in the 4QS converter, and 65- or 45-class devices in the traction inverter [32]. Under AC supply, the system employs a transformer and a 4QS converter, which stabilises the intermediate voltage. Under DC supply, the IGBTs of the 4QS converter operate in chopper mode, allowing voltage stabilisation as well.

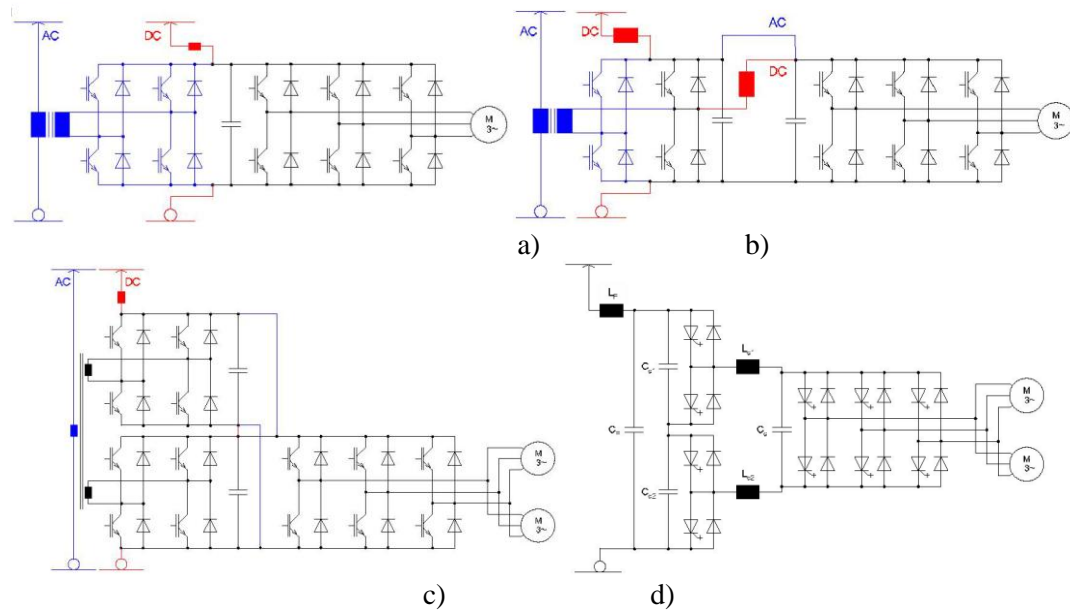

**Fig. 1. Traction system schemes of dual-system electric rolling stock**

a – non-chopper circuit for operation under DC 3 kV supply [31, 32]; b, c – chopper-based circuits for operation under DC 3 kV supply [31, 32]; d – voltage divider circuit for operation under DC 3 kV supply [34].

In the configuration shown in Fig. 1c, 33-class semiconductor devices may be used in both the 4QS converter and traction inverter. The use of two 4QS converters improves the power quality drawn from the AC network [33]. Thus, the schemes in Fig. 1b and Fig. 1c ensure stable DC-link voltage under both DC and AC operation modes.

It should be noted that when operating from a DC network, additional equipment must be integrated to form a circuit similar to the one shown in Fig. 1c.

An innovative approach to the design of dual-system traction systems involves the use of semiconductor converters with medium-frequency transformers (Power Electronic Transformers – PET, Medium Frequency Topologies or Solid-State Transformers – SST) [35]. These converters employ transformers operating at elevated frequencies. Several prototype devices of this type have already been developed and tested on railway rolling stock.

Fig. 2 presents circuits of converters with medium-frequency transformers that have undergone experimental validation, including on electric traction vehicles

In Fig. 2a, the diagram of the converter developed by Alstom for use on rolling stock supplied from a 15 kV, 16 2/3 Hz traction network is presented.

The technical parameters of the Alstom eTransformer converter are shown in Table 1. Its high-voltage input stage (stages 1 and 2) comprises an input reactor and eight series-connected conversion modules forming an AC–AC converter (multi-level configuration). The first stage is a full H-bridge AC converter, while the second stage is a half-bridge DC converter. The transformer’s primary winding is powered through a resonant circuit (capacitor and transformer leakage inductance) tuned to 5 kHz. Although stages 1 and 2 each include eight modules, stage 3 consists of a single H-bridge supplying the low-voltage DC link, equipped with an LC filter. Stage 1 operates with hard switching (since its switching frequency can be relatively low) and uses 6.5 kV/400 A IGBTs. Stage 2 operates with soft switching under quasi-zero current switching (quasi-ZCS) conditions and uses 3.3 kV IGBTs. In the event of a module failure, the faulty unit can be bypassed, allowing continued full-power operation. Both the semiconductors and transformer are cooled using a forced oil circulation system. Despite employing about three times as many semiconductors as traditional line-frequency transformer systems, the eTransformer offers superior power density and efficiency.

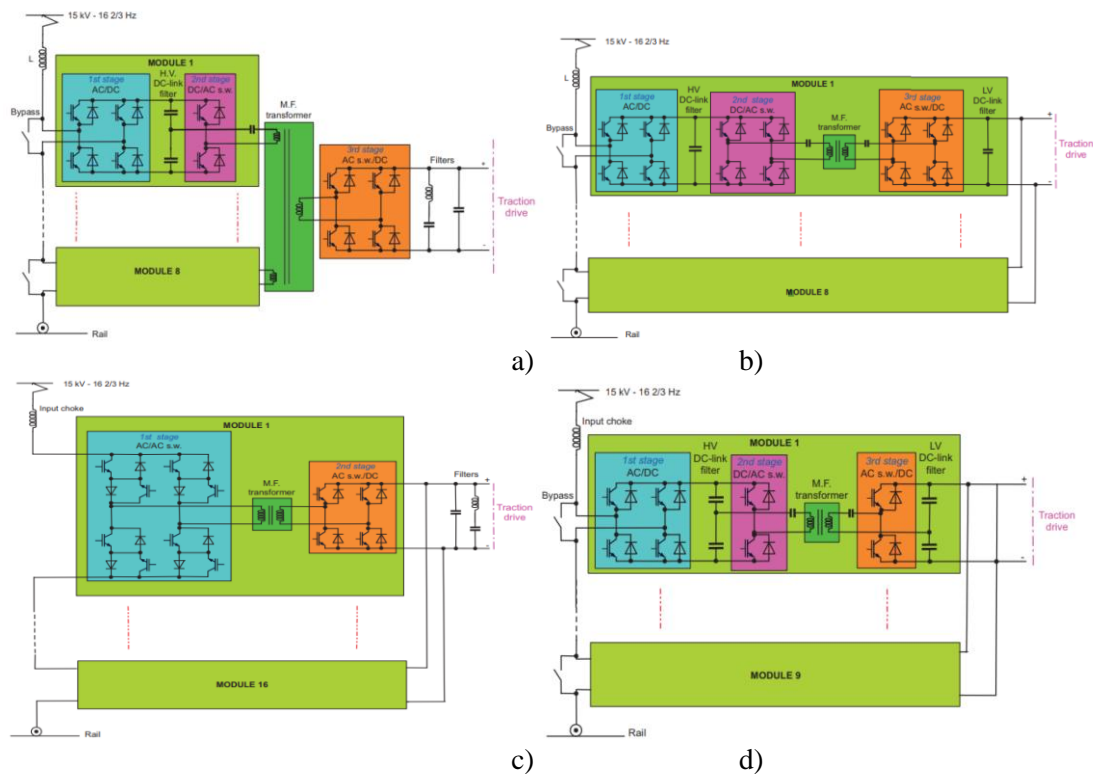

Fig. 2. Traction system schemes with converters employing medium-frequency transformers a – eTransformer circuit developed by Alstom [35]; b – “Medium Frequency Topology” converter developed by Bombardier Transportation [35]; c – ABB converter circuit [35]; d – ABB Power Electronic Traction Transformer [35].

Table 1. Technical parameters of the eTransformer converter [35]

Parameter	Value
Input voltage	15 kV
Input frequency	16.7 Hz
Output voltage	1.65 kV DC
Rating power	1500 kVA
Maximum power	2250 kVA (30 s)
Efficiency	94%
Transformer frequency	5 kHz
Transformer + electronic weight	2830 kg
Output LC filter weight	385 kg
Heat exchanger weight	255 kg
Overall weight	<3600 kg
Power density	0.42 kVA/kg
Total number of IGBTs	52
Cooling system	Forced oil circulation

Fig. 2b shows the “Medium Frequency Topology” converter developed by Bombardier Transportation for operation from a 15 kV, 16 2/3 Hz AC supply.

Similar to the eTransformer, this converter has three cascades consisting of eight identical modules connected in series. Unlike the eTransformer, which employs a single medium-frequency transformer,

in this configuration each module has its own transformer, while the low-voltage DC links of the modules are connected in parallel. The first cascade is a full-bridge AC/DC converter, the second cascade is a full-bridge DC/AC converter (whereas the eTransformer uses a half-bridge), and the third cascade is again a full-bridge AC/DC converter. If one of the modules fails, the topology can continue operation at 7/8 of nominal power. The system uses 6.5 kV IGBTs in the first stage, which means seven modules are sufficient for a 15 kV line voltage. Each transformer weighs only 18 kg and has a 1:1 turns ratio. The main drawback of this configuration is the large number of semiconductor devices and auxiliary components. The number of components can be reduced by using half-bridge topologies, as shown in other designs.

**Table 2. Technical parameters of the “Medium Frequency Topology” converter [35]**

Parameter	Value
Input voltage	15 kV
Input frequency	16.7 Hz
Output voltage	3.6 kV D
Rating power	3000 kVA
Transformer frequency	8 kHz
Transformers weight*	18 kg
Total number of IGBTs	96
Cooling system	Deionized water

\*Weight for each transformer

Fig. 2c presents the ABB converter design. Its parameters are summarised in Table 3. Unlike the previous examples, this converter has two cascades. It uses 3.3 kV, 400 A IGBTs arranged in 16 modules, doubling the number of units compared with other medium-frequency solutions, since lower-voltage transistors are used. Each module includes a 1:1 medium-frequency transformer operating at 400 Hz, which limits the reduction in transformer size. Therefore, the dimensions of this converter remain larger than those of traditional line-frequency transformers with 4QS converters.

**Table 3 – Technical parameters of the first ABB prototype converter [35]**

Parameter	Value
Input voltage	15 kV
Input frequency	16.7 Hz
Output voltage	1.8 kV DC
Rating power	1200 kVA
Transformer frequency	400 Hz
Total number of IGBTs	192
Cooling system	Forced oil circulation

In terms of efficiency, while this prototype shows about 3% higher efficiency than a traditional transformer under medium and high load, it performs worse at low load conditions. Furthermore, its requirement for 192 IGBTs makes the design heavy and complex; hence, this prototype is now considered obsolete.

Fig. 2d shows the ABB Power Electronic Traction Transformer (PETT), whose parameters are listed in Table 4.

The converter has three cascades and includes nine series-connected modules, one of which serves as a reserve. Each module contains its own medium-frequency transformer. The first cascade is a full H-bridge AC/DC converter using 6.5 kV–400 A IGBTs that supply a 3.6 kV DC link; the second is a half-bridge DC/AC converter employing the same transistor type; and the third is a half-bridge AC/DC converter using 3.3 kV–800 A IGBTs. The resonant circuit (LLC type) uses both magnetising and leakage inductances to achieve resonance, allowing the elimination of the LC filter and minimising size

and weight. Although the power density (0.266 kVA/kg nominal, 0.4 kVA/kg maximum) is still relatively low, the achieved 96% efficiency is substantially higher than that of conventional line-frequency transformer systems with 4QC converters.

**Table 4. Technical parameters of the ABB Power Electronic Traction Transformer [35]**

Parameter	Value
Input voltage	15 kV
Input frequency	16.7 Hz
Output voltage	1.5 kV DC
Rating power	1200 kVA
Maximum power	1800 kVA
Efficiency	96%
Total number of IGBTs	72
Total weight	4500 kg
Power density	0.266 kVA/kg

It should be emphasised that all analysed medium-frequency converters were designed for 15 kV, 16 2/3 Hz railway networks, where their reduced weight gives a considerable advantage. Nevertheless, despite these benefits, their large-scale adoption in rolling stock has not yet occurred. Medium-frequency converters have found use primarily in traction systems equipped with onboard batteries [36].

Research on medium-frequency converters for 25 kV, 50 Hz systems remains largely theoretical, focusing on various design aspects [37–39].

Ukrainian studies [10, 12] also explored their application in domestic dual-system electric trains, proposing suitable circuit structures and calculating key parameters. Thus, while these converters are not yet in operational use on traction rolling stock, their lower mass and volume make them attractive, especially when onboard energy storage systems—requiring significant space and weight—are to be installed.

Given this analysis, a hybrid traction system for suburban trains can be developed using either traditional circuit design principles or innovative medium-frequency converter technology. The first approach relies on proven, reliable technical solutions suitable for current rolling stock. The second promises reduced mass, smaller installation volume, and higher energy efficiency, though practical validation of reliability and cost-efficiency remains necessary.

Let us consider possible variants of traction circuit arrangements using the traditional approach to traction system design, as well as configurations employing converters with a medium-frequency transformer.

Fig. 3 shows the schematic diagram of a hybrid traction system constructed on the basis of traditional design principles.

When operating from the AC traction network, switch  $QF1$  and contactors  $K1$ ,  $K2$  and  $K3$  are closed, while  $QF2$  and contactors  $K1$  and  $K4$  remain open. Power is supplied via the traction transformer  $T$ , whose secondary windings feed semiconductor converters  $A1$  and  $A2$  through additional reactors  $L$ . Converters  $A1$  and  $A2$  operate according to 4QS converter algorithms, which ensure DC-link voltage stabilisation and maintain a near-zero phase shift between current and voltage. The outputs of  $A1$  and  $A2$  are connected in parallel, and a double-frequency filter  $F$  is used to suppress harmonics.

When operating from the DC traction network, switch  $QF2$  and contactors  $K1$  and  $K4$  are closed, while  $QF1$  and contactors  $K2$  and  $K3$  are open. Each of the capacitors  $C$  in the voltage divider is connected to converters  $A1$  and  $A2$ , effectively halving the input voltage of each converter compared with the contact network voltage. Reactors  $L1$  and  $L2$  are connected to the converter outputs to smooth current pulsations, and their outputs are paralleled - forming a four-phase pulse-width modulation converter.

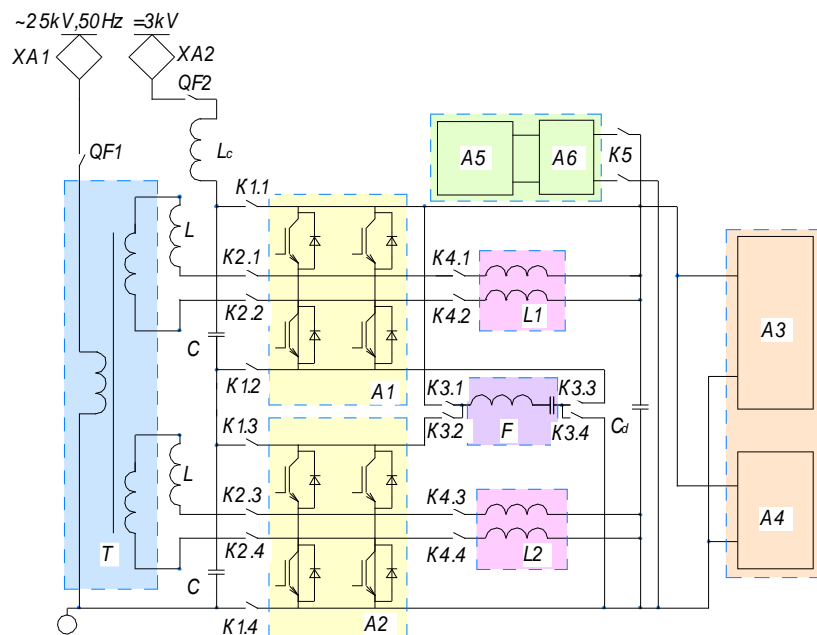

**Fig. 3. Schematic diagram of a hybrid traction system for a dual-supply electric train**

*XA1, XA2* – pantographs for AC and DC supply respectively; *QF1, QF2* – protection devices; *L<sub>c</sub>* – input choke; *T* – traction transformer; *L* – transformer reactor; *C* – capacitors of the voltage divider; *A1, A2* – input semiconductor converters; *F* – double-frequency filter; *L1, L2* – output chokes; *K1...K4* – main circuit contactors; *K5* – switch of the energy storage system; *A3* – traction inverter block; *A4* – auxiliary converters; *A5* – energy storage system; *A6* – matching converter; *C<sub>d</sub>* – DC-link capacitor

A line choke *L<sub>c</sub>* limits current ripples drawn from the DC network.

In both supply modes, the energy storage system (comprising the storage unit *A5* and matching converter *A6*) is connected to the intermediate circuit via switch *K5*. The traction inverters block *A3* powers and controls asynchronous traction motors, while *A4* supplies auxiliary systems.

From the above description, it follows that under DC operation, each converter receives half the contact voltage, varying between 1.1 and 2.0 kV. Since the converters are of the step-down type, the DC-link voltage does not exceed 1.1 kV, ensuring its stabilisation despite fluctuations in the contact network. With a DC-link voltage of 900–1000 V, 17-class IGBTs can be used in the traction converter.

Fig. 4 shows a variant of the hybrid traction system employing a medium-frequency converter based on a three-cascade configuration.

When supplied from the AC traction network, *QF1* is closed, *QF2* and contactor *K* are open. The first-stage converters *A1* of each module operate according to 4QS algorithms, stabilising the voltage on capacitor *C*. Converters *A2, A3*, and the transformer *MF* reduce the voltage to the required level for traction drive operation. The energy storage system (*A6* and *A7*) is connected to the intermediate DC link that also powers the traction inverter block *A4* and auxiliary converters *A5*.

When supplied from the DC network, *QF1* is open while *QF2* and *K* are closed, connecting the capacitors *C* of all modules directly to the contact network. Thereafter, the operation proceeds identically to the AC mode described above.

To reduce the number of transistors, 65-class IGBTs are used in the first-stage converters. With 12 series-connected modules, the voltage across capacitors reaches 3.4 kV; considering that the contact network voltage may reach 4.0 kV, 65-class IGBTs are also required in the second cascade. Alternatively, the second cascade may use a modular converter design [40]. The traction drive DC-link voltage can be selected within 900–1000 V, which allows the use of 17-class transistors in the traction inverter.

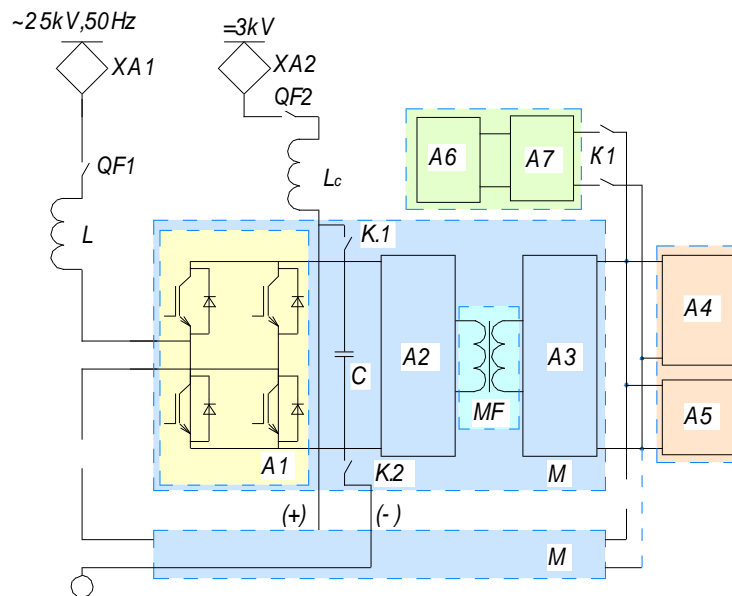

**Fig. 4. Schematic diagram of a hybrid traction system with a medium-frequency converter for a dual-supply electric train**

*XA1, XA2* – pantographs for AC and DC supply respectively; *QF1, QF2* – protection devices; *L<sub>c</sub>* – input choke; *L* – additional choke; *C* – input capacitor; *A1* – first-stage converter; *A2* – second-stage converter; *A3* – third-stage converter; *MF* – medium-frequency transformer; *M* – converter module with medium-frequency transformer; *K* – main circuit contactor; *K1* – switch of the energy storage system; *A4* – traction inverter block; *A5* – auxiliary converters; *A6* – energy storage system; *A7* – matching converter.

Energy storage and matching converters are generally designed for DC-link voltages not exceeding 1000 V. Thus, adopting an intermediate voltage below 1000 V enables the use of standardised, proven industrial components.

Thus, the use of both traction system configurations considered in this study is technically feasible. At present, the scheme based on traditional design approaches demonstrates high energy performance. These configurations employ equipment whose manufacturing quality is well established, which ensures high operational reliability of such systems when used in electric rolling stock. The configuration employing converters with a medium-frequency transformer is an innovative solution that requires further research and practical validation under operational conditions. In addition, a comprehensive techno-economic assessment is necessary, as well as an evaluation of its impact on the performance characteristics of electric rolling stock. In view of these considerations, the traditional approach remains the priority for the development of a hybrid traction system for a suburban electric train at the current stage. This approach enables the creation of a hybrid traction system with high reliability indicators.

**Conclusions.** The study proposes hybrid traction systems for a dual-supply suburban electric train. A comprehensive analysis of modern traction system design approaches was conducted, forming the basis for the proposed concepts.

The first variant - based on traditional circuit design - ensures high reliability through the use of time-tested solutions. The second - an innovative configuration employing medium-frequency transformers - offers potential advantages in reduced weight, smaller equipment volume, and increased energy efficiency. However, due to insufficient data regarding their technical and economic characteristics, the traditional design approach remains preferable.

It has been demonstrated that selecting an intermediate DC-link voltage not exceeding 1000 V expands the range of compatible commercial components for onboard energy storage systems and converters.

## REFERENCES

1. Borsuk, Yu.V. (2025) Suburban railway transportation in Ukraine: features of territorial organization and development trends [in Ukrainian]. [Electronic resource]. Access mode: [https://geography.lnu.edu.ua/wp-content/uploads/2025/09/Borsuk\\_Prymiski-zaliznychni-perevezennia-v-Ukraini\\_2025.pdf](https://geography.lnu.edu.ua/wp-content/uploads/2025/09/Borsuk_Prymiski-zaliznychni-perevezennia-v-Ukraini_2025.pdf).
2. Ukrzaliznytsia (2025). Suburban train schedule. [in Ukrainian]. [Electronic resource]. Access mode: [https://uz.gov.ua/passengers/suburban\\_train\\_schedule/](https://uz.gov.ua/passengers/suburban_train_schedule/).
3. Private Joint-Stock Company "Kyiv Electric Wagon Repair Plant" (2025). [in Ukrainian]. [Electronic resource]. Access mode: <https://kevrz.com.ua/index.php/ua/>.
4. Chyhrinov, V. (2024). Retrospective analysis of suburban passenger transportation indicators of the regional branch of JSC «Ukrzaliznytsya». *Sustainable economic development*. 3(50), 458-467. [in Ukrainian] <https://doi.org/10.32782/2308-1988/2024-50-69>.
5. Lomotko, D. V., Krasnoshtan, O. M., Kava, O. S. (2022). Ways to restore the logistics of suburban passenger rail transportation on non-electrified sections of the railway. *Information and control systems in railway transport*, 4, P.41-47. [in Ukrainian].
6. Sablin, O. I., Kuznetsov, V. G., Artemchuk V. V. (2013). Problems and prospects of effective use of electricity recovery in the electric transport system. *Optical-electronic information and energy technologies*, 2, P. 126-130. [in Ukrainian].
7. Buriakovskiy, S. H., Overianova, L. V., Neshcheret, V. O., Ivanov, K. I. (2023). Assessment of the energy saving potential when using energy recovery in a railcar electric rolling stock for suburban transportation. *Bulletin of the National Technical University "KhPI". Series: Energy and heat engineering processes and equipment*, 3(15), 52-59 <https://doi.org/10.20998/2078-774X.2023.03.08>. [in Ukrainian].
8. N. A. Kostyn, A. V. Nykytenko. (2014). Autonomy of recuperative braking is the basis of reliable and energy-efficient recuperation on electromotive components of direct current. *Railway transport of Ukraine*, 3, P. 15–22. [in Ukrainian].
9. Shylo, S. I. (2025). Increasing the efficiency of traction transmission of direct current electric trains: author's abstract of dissertation ... candidate of technical sciences: 05.22.09. Dnipro, 26 p. [in Ukrainian].
10. Zabarylo D. O. (2015). Increasing the efficiency of dual-supply electric rolling stock with asynchronous traction drive: author's abstract of thesis ... candidate of technical sciences: 05.22.09. Dnipropetrovsk. 25 p. [in Ukrainian].
11. Demydov O. V. (2021). Energy-efficient gearless traction drive of a suburban electric train based on a synchronous motor with permanent magnets: author's abstract of the dissertation ... candidate of technical sciences: special. 05.22.09 Kharkiv, 21 p. [in Ukrainian].
12. Mukha, A. M. (2011). Development of scientific foundations for the creation of traction power transmissions of multi-system electric locomotives [Text]: dissertation ... Dr. Tech. Sciences: 05.22.09. Dnipropetrovsk National University of Railway Transport named after V. Lazaryan, - 362 pages. [in Ukrainian].
13. Hulak S. O. (2020). Increasing the energy performance of AC electric locomotives due to reactive power compensation adapted to the power supply system: dissertation ... candidate of technical sciences: special 05.22.09:– Kharkiv, 209 p. [in Ukrainian].
14. Krasnov O. O. (2020). Active traction converter for AC electric locomotives with collector traction motors: dis. ... candidate of technical sciences : 05.22.09 : Kharkiv, 188 p. [in Ukrainian].
15. Overianova, L.V. (2014). Determination of parameters and assessment of properties of electromechanical inertial energy storage devices for suburban electric trains: author's abstract of the dissertation of candidate of technical sciences: 05.22.09, Kharkiv, 20 p. [in Ukrainian].
16. Sulym, A.O. (2023). Increasing the efficiency of electricity use for regenerative braking of metro trains by introducing on-board capacitive energy storage devices [Text]: monograph. *State Property Fund of Ukraine, State Enterprise "Ukr. Research Institute of Carriage Building" (SE "UkrNDIV")*. Kremenchuk: SE "UkrNDIV", 104 p. [in Ukrainian].
17. Kondratieva L. Yu. (2025). Energy-efficient control of the traction electric drive of a quarry locomotive with a combined power plant: dissertation ... doctor of philosophy : special. 141, Kharkiv, 193 s. [in Ukrainian].
18. Yatsko, S., Vashchenko, Ya., Sydorenko, A. (2019). Development of strategies for reducing traction energy consumption by electric rolling stock. *JCPPEE*, Volume 9, Number 1, pp. 44-51 <https://doi.org/10.23939/jcpee2019.01.044>.
19. Maslii, A., Buriakovskiy, S., Antonenko, R., Gevrasov, V., Maslii, A. (2025). Assessing the applicability of energy storage system for plug-in hybrid traction system in rail rolling stock. *Eastern-European Journal of Enterprise Technologies*, 4(1 (136)), 22–31. <https://doi.org/10.15587/1729-4061.2025.337731>.
20. Afanasov, A. M., Lynyk, D. I., Arpul, S. V., Bilukhin, D. S., Vasyliiev, V. Ye. (2022). Prospects for the use of autonomous electric trains with on-board energy storage. *Transport systems and transportation technologies*, (23), S.46-51. <https://doi.org/10.15802/tstt2022/261652>.
21. Steiner, M., Klohr, M., Pagiela, S. (2007). Energy storage system with ultracaps on board of railway vehicles. *2007 European Conference on Power Electronics and Applications*, Aalborg, Denmark, pp. 1-10, <https://doi.org/10.1109/EPE.2007.4417400>.

22. Kono, Y., Shiraki, N., Yokoyama, H., Furuta, R. (2014). Catenary and storage battery hybrid system for electric railcar series EV-E301. *2014 International Power Electronics Conference (IPEC-Hiroshima 2014 - ECCE ASIA)*, Hiroshima, Japan, 2014, pp. 2120-2125, <https://doi.org/10.1109/IPEC.2014.6869881>.
23. Ogasa, M. (2010), Application of Energy Storage Technologies for Electric Railway Vehicles—Examples with Hybrid Electric Railway Vehicles. *IEEJ Trans Elec Electron Eng*, 5: 304-311. <https://doi.org/10.1002/tee.20534>.
24. Yoshiaki, TAGUCHI, Satoshi KADOWAKI, Takayuki NAKAMURA, Masaki MIKI, Kenji HATAKEDA, Yoshimasa ARITA. (2015). Development of a Traction Circuit for Battery-powered and AC-fed Dual Source EMU and Running Test Evaluation of the On-board Battery Performance, *Quarterly Report of RTRI*, Volume 56, Issue 2, Pages 98-104, Released on J-STAGE June 09, 2015, <https://doi.org/10.2219/rtriqr.56.98>, [Electronic resource]. Access mode: [https://www.jstage.jst.go.jp/article/rtriqr/56/2/56\\_98/article/-char/en](https://www.jstage.jst.go.jp/article/rtriqr/56/2/56_98/article/-char/en).
25. Bombardier Talent 3 Battery Train (2025) [Electronic resource]. Access mode: <https://www.railway-technology.com/projects/bombardier-talent-3-battery-train/?cf-view&cf-closed>.
26. FLIRT Akku: continues where the overhead line ends (2025) [Electronic resource]. Access mode: <https://www.stadlerail.com/en/solutions/rolling-stock/mainline-flirt-akku>.
27. Hybrid Multiple Units (2025) [Electronic resource]. Access mode: <https://assets.new.siemens.com/siemens/assets/api/uuid:0a451202-2be4-485d-a736-974d74263e63/siemens-mobility-mireo-plus-b-mireo-plus-h-en.pdf>.
28. Becker, F., Dämmig, A. (2016). Catenary free operation of light rail vehicles — Topology and operational concept. *18th European Conference on Power Electronics and Applications (EPE'16 ECCE Europe)*, Karlsruhe, Germany, pp. 1-10, <https://doi.org/10.1109/EPE.2016.7695286>.
29. Battery Powered Trains (2025) [Electronic resource]. Access mode: <https://www.hitachirail.com/products-and-solutions/rolling-stock/battery-powered-trains/>.
30. Karkosiński, D., Stromski, P., Karkosińska Brzozowska, N. (2021). Hybrid energy storage for electric multiple units to operate at the partially electrified line Gdynia-Hel. *Rail Vehicles. Pojazdy Szynowe*, (1), 18–32. <https://doi.org/10.53502/RAIL-138488>.
31. Steimel, A. (2008). Electric traction - motive power and energy supply : basics and practical experience. Access mode: <https://www.iqytechnicalcollege.com/Electric%20Traction%20-%20Motion%20Power%20and%20Energy%20Supply%20Basics%20and%20Practical%20Experience.pdf>.
32. Eckel, H.-G., Bakran, M. M., Krafft, E. U., Nagel, A. (2005). A new family of modular IGBT converters for traction applications. *2005 European Conference on Power Electronics and Applications*, Dresden, Germany, P.10, <https://doi.org/10.1109/EPE.2005.219248>.
33. Plakhtii, O., Nerubatskyi, V., Sushko, D., Ryshchenko, I., Tsybulnyk, V., & Hordiienko, D. (2019). Improving energy characteristics of ac electric rolling stock by using the three-level active four-quadrant rectifiers. *Eastern-European Journal of Enterprise Technologies*, 4(8 (100)), 6–14. <https://doi.org/10.15587/1729-4061.2019.174112>.
34. Bakran M. M., Eckel, H.-G., Eckert, P., Gambach, H., Wenkemann, U. Comparison of multisystem traction converters for high-power locomotives. *2004 IEEE 35th Annual Power Electronics Specialists Conference*, Aachen, Germany, 2004, pp. 697-703 Vol.1, <https://doi.org/10.1109/PESC.2004.1355833>.
35. Farnesi, S., Marchesoni, M., Passalacqua, M., Vaccaro, L. (2019). Solid-State Transformers in Locomotives Fed through AC Lines: A Review and Future Developments. *Energies*, 12(24), 4711. <https://doi.org/10.3390/en12244711>
36. BORDLINE® M400\_DC\_3000V\_M For Hybrid Bi-Mode Locomotives (2025) [Electronic resource]. Access mode: [https://library.e.abb.com/public/5f0dd4e9c23c4f19842ac96a34a85872/BORDLINE%20M400\\_DC\\_3000V\\_M.pdf](https://library.e.abb.com/public/5f0dd4e9c23c4f19842ac96a34a85872/BORDLINE%20M400_DC_3000V_M.pdf).
37. Dong-Uk Kim, Jin-Hyuk Park, Seung-Hwan Lee, Sungmin Kim (2025). Development of medium voltage single-phase solid-state transformer for high-speed railway vehicles: reduced scale verification results. *High Voltage*, 10(3), 555–569 (2025). <https://doi.org/10.1049/hve2.70061>.
38. Morel, F., Stackler, C., Ladoux, P., Fouineau, A., Wallart, F., Evans, N., Dworakowski, P. (2019). Power electronic traction transformers in 25 kV / 50 Hz systems: Optimisation of DC/DC Isolated Converters with 3.3 kV SiC MOSFETs. *PCIM Europe 2019; International Exhibition and Conference for Power Electronics, Intelligent Motion, Renewable Energy and Energy Management*, Nuremberg, Germany, 2019, pp. 1-8.
39. E. S. Lee, J. H. Park, M. Y. Kim, J. S. Lee. (2022). High-Efficiency Module Design of Solid-State Transformers for Railway Vehicles, *IEEE Transactions on Transportation Electrification*, vol. 8, no. 1, pp. 98-120, <https://doi.org/10.1109/TTE.2021.3101733>.
40. Adamowicz, M., Szewczyk, J. (2020). SiC-Based Power Electronic Traction Transformer (PETT) for 3 kV DC Rail Traction. *Energies*, 13(21), 5573. <https://doi.org/10.3390/en13215573>.

**Євген Рябов<sup>1</sup>, Лілія Овер'янова<sup>2</sup>, Костянтин Іванов<sup>4</sup>, Ірина Білоконь<sup>4</sup>, Антон Жуков<sup>5</sup>**

<sup>1</sup>Доцент, Кафедра електричного транспорту та тепловозобудування, Національний технічний університет «Харківський політехнічний інститут», вул. Кирпичова, 2, м. Харків, 61002, Україна. ORCID: <https://orcid.org/0000-0003-0753-514X>.

<sup>2</sup>Доцент, Кафедра електричного транспорту та тепловозобудування, Національний технічний університет «Харківський політехнічний інститут», вул. Кирпичова, 2, м. Харків, 61002, Україна  
ORCID: <https://orcid.org/0000-0002-4827-572X>.

<sup>3</sup>Аспірант, Кафедра електричного транспорту та тепловозобудування, Національний технічний університет «Харківський політехнічний інститут», вул. Кирпичова, 2, м. Харків, 61002, Україна  
ORCID: <https://orcid.org/0009-0000-3000-8191>.

<sup>4</sup>Директор, Кременчуцький фаховий коледж транспортної інфраструктури та технологій, вул. Юрія Руфа, 14, м. Кременчук, Полтавська область, 39600, Україна.  
ORCID: <https://orcid.org/0000-0002-4675-3994>.

<sup>5</sup>ТОВ «Харківський електро-машинобудівний завод», пр. Героїв Харкова, 199, Харків, 61037, Україна  
ORCID: <https://orcid.org/0009-0001-5229-1685>.

### **Розробка гібридної тягової системи для приміського електропоїзду з двосистемним живленням**

***Анотація.** У статті розглянуто та проаналізовано варіанти побудови тягових систем сучасного електрорухомого складу. Розглянуто та проаналізовано тягові системи, в яких використовуються традиційні підходи до схемотехнічних рішень. Проведено огляд тягових систем з перетворювачами з середньочастотними трансформаторами, використання яких зменшує масу електрообладнання, потребує меншого простору для його розміщення та підвищує енергоефективність електрорухомого складу. Показано, що пріоритетним є використання гібридної тягової системи з традиційною схемотехнікою, обладнання для якої має високі показники надійності. Запропоновано варіанти гібридних тягових систем для приміського електропоїзду з двосистемним живленням. Показано доцільність стабілізації напруги проміжного контуру для забезпечення автономності енергообміну між системою накопичення енергії та тяговим електроприводом. Проведено опис роботи схем та показано, що при виборі напруги проміжної ланки не вище 1000 В можливе використання серійних технічних рішень в обладнанні системи накопичення енергії. Запропоновані гібридні тягові системи можуть бути використанні при модернізації чи створенні моторвагонного електрорухомого складу, а також бути використанні на іншому рейковому транспорті.*

**Ключові слова:** електрорухомий склад, енергоефективність, гібридна тягова система, тяговий електропривод, накопичувач енергії, тяговий перетворювач, тяговий трансформатор, тяговий асинхронний електродвигун.

*Дата першого надходження статті до видання 20.09.2025*

*Дата прийняття до друку статті 17.11.2025*

UDC 629.429.3:621.313

**Oleksandr Khaustov<sup>1</sup>, Borys Liubarskyi<sup>2\*</sup>**

<sup>1</sup>Postgraduate student, Department of Electric Transport and Locomotive Engineering, National Technical University "Kharkiv Polytechnic Institute", 2, Kyrpychova str., Kharkiv, 61002, Ukraine. ORCID: <https://orcid.org/0009-0001-0363-6173>.

<sup>2</sup>Professor, Department of Electric Transport and Locomotive Engineering, National Technical University "Kharkiv Polytechnic Institute", 2, Kyrpychova str., Kharkiv, 61002, Ukraine. ORCID: <https://orcid.org/0000-0002-2985-7345>.

\*Corresponding author: [boris1911@ukr.net](mailto:boris1911@ukr.net).

### **Optimization of energy storage parameters of electric buses charged at terminal stops**

*The paper developed a methodology for determining the optimal parameters of a combined energy storage for an electric bus based on solving a conditional minimization problem taking into account the driving mode, route parameters, and weight and size restrictions when charging the storage at the final stops of the route. The practical significance of the work lies in determining the parameters of combined energy storage for an electric bus using the example of a multi-component energy storage. Analysis of the results of the study on solving the optimization problem proved that for economical driving on routes 4 and 10, three-component storage with 1 branch with LTO cells and 28 branches with LFP cells and 1 branch of supercapacitors are optimal. For driving in intermediate and high-speed modes, two-component storage with the parameters: 2 branches with LTO cells and 15 branches with LFP cells and 1 branch with LTO cells and 47 branches with LFP cells, respectively, are optimal. For the obstacle mode, a storage device operating in the "high-speed" mode is sufficient for 10 routes, however, for the 4th route, which requires higher energy consumption, it is necessary to use a mono-component LFP - element storage device with 81 branches.*

**Keywords:** *traction drive, energy storage, electric bus, trolleybus, parameter optimization, objective function*

**Introduction.** Within the urban fabric of Ukraine's major metropolitan areas, trolleybuses and their modern successors, electric buses, have established themselves as the principal modalities of trackless passenger transport, collectively constituting a substantial proportion of the municipal vehicle fleets. Their pervasive deployment, a process initiated in the latter half of the twentieth century and persistently ongoing, is fundamentally predicated upon a suite of operational advantages they exhibit over conventional internal combustion engine buses.

Foremost among these merits is their superior environmental profile; as vehicles powered by external electrification, trolleybuses generate zero direct harmful emissions at the point of use, with their environmental impact being predominantly indirect and contingent upon the generation mix of the electrical grid. A second, significant advantage lies in their capacity for kinetic energy recuperation. Through regenerative braking systems, contemporary trolleybus models can reclaim and feedback into the overhead contact wire up to 70% of the energy otherwise dissipated as heat during deceleration. Thirdly, from a lifecycle perspective, trolleybuses typically demonstrate an extended service longevity compared to buses, a characteristic attributable to the absence of high-vibration internal combustion engines, which consequently imposes reduced mechanical stress on structural components.

Notwithstanding these notable benefits, it would be an oversimplification to envisage the conventional trolleybus of future urban transit ecosystems due to a constellation of inherent operational limitations. A primary constraint is their compromised maneuverability, dictated by an absolute dependence on a fixed overhead contact network. This tethering not only restricts routing flexibility but also necessitates considerable capital investment for the initial infrastructure deployment and any subsequent network expansion. Furthermore, trolleybuses exhibit a pronounced sensitivity to both the integrity of the road surface and the condition of the contact infrastructure. Traversing degraded road sections mandates a significant reduction in velocity to prevent the dewirement of the current collection pantographs. Moreover, the intrinsic design of contact network elements—such as intersections, switches, and sectional insulators on drawbridges—imposes mandatory speed restrictions for safe passage. An additional vulnerability is their susceptibility to the icing of contact wires, a phenomenon that can severely degrade the quality of electrical contact and accelerate the abrasive wear of the pantograph's contact inserts. Finally, the perpetual maintenance demands of the extensive overhead wire system necessitate a dedicated cadre of skilled personnel, a requirement that poses acute challenges in the context of martial law in Ukraine, complicating both training and retention of such specialized staff.

The synthesis of the aforementioned advantages with the mitigation of the described disadvantages is potentially achievable through the adoption of battery electric buses, or simply electric buses, as a primary mode of public conveyance. This technology retains a high degree of environmental and energy efficiency while conferring excellent operational maneuverability, thereby enabling dynamic and flexible routing with permissible deviations. The principal limiting parameters in this context are the energy density and capacity of the onboard energy storage systems and the concomitant availability of a suitably distributed charging infrastructure.

For the purpose of a comprehensive analysis of energy consumption in trackless electric public transport, the following vehicle typologies, distinguished by their energy storage and charging strategies, are considered:

A long-range electric bus, equipped with high-capacity energy storage systems that afford an autonomous operational range of approximately 150 to 250 kilometers. This class primarily relies on scheduled charging sessions, typically conducted overnight within depot facilities.

A medium-range electric bus, featuring a battery of moderate capacity designed for an autonomy of up to 50 kilometers. Its operational paradigm is supported by frequent, fast-charging interventions (with durations of 10 to 30 minutes) at terminal stops or designated charging stations along the route.

A short-range electric bus, utilizing a minimally-sized battery pack sufficient for a range of up to 10 kilometers. This model depends on opportunistic, short-term charging sessions at regular passenger stops, with charging durations comparable to the time spent for passenger boarding and alighting.

A pivotal and actively pursued research domain within this field is the development of sophisticated energy flow management strategies for electric power conversion systems that are equipped with hybrid or combined energy storage assemblies. The conceptual advancement embodied by this technology is the systemic integration of heterogeneous storage elements—specifically, those engineered for high power density (to manage rapid charge/discharge cycles, e.g., during acceleration and regenerative braking) synergistically with those optimized for high energy density (to sustain extended range and base load).

**Analysis of recent research and problem statement.** An examination of hybrid energy storage systems, which integrate disparate lithium-cell chemistries, was conducted in [1]. The investigation revealed that such heterogeneous configurations yield a marked enhancement in performance metrics, demonstrating a 5.56% increase in energy density and a substantial 28.21% improvement in specific energy relative to conventional, homogeneous lithium-cell battery assemblies. Corroborating these findings, the research delineated in [2] established that hybrid topologies—specifically those synergistically combining Nickel Manganese Cobalt (NMC) cells, prized for their high specific energy, with Lithium Titanate (LTO) cells, renowned for their high specific power—can achieve a mass reduction of up to 33.5% or a cost diminution of up to 30% compared to monochemical battery systems. Further substantiating the economic viability of this approach, the optimization study presented in [3],

focused on hybrid batteries comprising lithium cells of different chemistries, concluded that such hybrid energy storage systems possess the potential to significantly reduce aggregate costs in comparison to systems utilizing a single cell type.

Consequently, scholarly inquiries dedicated to the determination of optimal parameters and the development of sophisticated methodologies for the optimization of hybrid energy storage devices for electric rolling stock are of profound contemporary relevance. These research endeavors provide a critical pathway for achieving substantial enhancements in the efficacy and performance of energy storage technologies deployed in modern vehicular assets.

When undertaking an assessment of energy efficiency, it is imperative to ensure a high degree of fidelity between calculated models and the actual operational parameters empirically recorded during the service of public transport within a dense urban milieu. To this end, the development of a representative driving cycle is a foundational prerequisite. This cycle must constitute a computationally derived velocity-time profile that accurately encapsulates the real-world kinematic patterns—comprising accelerations, decelerations, idling periods, and cruising speeds—characteristic of trackless passenger vehicles navigating city streets.

The initial phase in the derivation of such a cycle involved the selection of a prototypical urban public transport route. For this study, the selection process was predicated upon bus routes operational within the Ukrainian city of Ivano-Frankivsk, a locale characterized by high traffic density and recurrent congestion at the time of the investigation [4,5]. To identify the route most faithfully reflective of standard urban public transport operating conditions, a set of rigorous selection criteria was instituted. Primarily, the analysis was confined exclusively to bus routes, as the principal research objective was to scrutinize technical solutions for enhancing the environmental performance of the extant trackless public transport fleet via a transition to electric traction. Secondly, a stipulation was imposed that all intermediate stops along the candidate route must be situated strictly within the city's jurisdictional boundaries. Thirdly, a meticulous spatial analysis of the stop distribution was performed, with particular emphasis accorded to routes traversing the central and historical districts, which typically present the most demanding operational profiles. Based on a holistic application of these considerations, bus Routes 4 and 10 were identified as possessing the highest degree of representativeness for subsequent modeling [6,7,8].

The application of this representative cycle to the sizing of an energy storage system for electric buses on Routes 4 and 10, under a depot-charging operational paradigm [9], indicates that a single- or dual-component storage architecture is optimal. The implementation of a three-component storage device, by contrast, was determined to be non-optimal. For an economical operational mode on Route 4, the optimal configuration is a two-component accumulator, comprising 147 branches equipped with Lithium Iron Phosphate (LFP) elements and 1 branch with supercapacitors. For Route 10, a mono-accumulator based on 131 branches of LFP elements was found to be optimal. This specific operational mode is applicable when organizational requirements for electric bus deployment are coupled with rational stipulations for passenger transportation speeds. The mass of the optimal storage systems for Routes 4 and 10 is 2.52 tonnes and 2.14 tonnes, respectively, with associated costs of 115 thousand euros and 93.52 thousand euros.

However, when the operational model shifts to "with obstacles" modes—simulating scenarios of severe traffic congestion or detours—the mass and cost parameters for the storage systems on Routes 4 and 10 escalate significantly. The mass increases to 5.47 tonnes and 4.71 tonnes (representing a 2.17-fold and 2.2-fold increase), while the cost rises to 245.8 thousand euros and 210.6 thousand euros (a 2.13-fold and 2.25-fold increase), respectively. This substantial inflation is directly attributable to a 2.31-fold intensification of the energy capacity requirements for the storage devices. Furthermore, the optimal type of storage device undergoes a transition under these constrained conditions. For Route 4, the optimal configuration becomes a two-component system with 1 branch of LTO cells and 316 branches of LFP cells, while for Route 10, a mono-component system of 281 branches with LFP cells is prescribed. Under a depot-charging regime, energy capacity emerges as the paramount indicator for storage device sizing. Nonetheless, the power output of the resultant optimal energy storage systems is

found to be excessive, exceeding the minimum requirement of 180 kW by a factor of 2.05 to 3.29, which is indicative of a sub-optimal and economically irrational allocation of resources [9].

**The purpose and tasks of the study.** The purpose of the work is to determine the parameters of a multi-component energy storage device for an electric bus that is charged at non-terminal stops using the example of vehicles for providing trolleybus routes 4 and 10 in Ivano-Frankivsk.

Tasks of the work.

1. Determine the energy indicators (power and energy intensity) of energy storage devices that can ensure the operation of an electric bus when servicing routes.

2. Develop a methodology for determining the parameters of a multi-component energy storage device based on conditional minimization methods.

3. Determine the parameters of a multi-component energy storage device for electric buses.

**Materials and methods of research.** This study focuses on a detailed analysis of trolleybus routes No. 4 and No. 10. These routes were selected for in-depth study due to their significant role in the city's public transportation structure, as they provide essential and convenient mobility services to a wide range of passenger demographics. A schematic representation of the operational route and geographic distribution of route No. 4.

A preliminary analysis of route No. 4 allows us to identify several primary segments characterized by exceptionally high traffic volumes. These critical nodes include the intersection of Halytska and Dnistrovska Streets, as well as the confluence of Dnistrovska and Vasylyanok Streets, both of which experience consistently high levels of vehicular throughput. Furthermore, recurring congestion is systematically observed along Halytska Street, particularly along the section from Trolleybusna Street to the bridge structure, including the immediate approaches and exits. An additional critical point of vehicle concentration is the intersection located directly on Halytska Street, which also experiences significant traffic volume. Fundamental operational data for route No 4, covering the section from Firma "Barva" to Dnistrovska Street, are presented in summary form in Table 1 [6,7].

*Table 1. Initial data for route No. 4 Barva Company - Dnistrovska Street*

Indicator name	Direct direction	Reverse direction
Route length, km	10.94	9.58
Technical speed, km/ h	29	
Number of working days, days.	365	
Number of stops, units	15	14
Zero mileage, km	0.65	0.38

In parallel, a study of route No 10 reveals a separate set of key segments characterized by difficult road conditions and persistent traffic delays. These problem areas include: the section from Symonenko Street to Mykolaychuka Street; the section from Stusa Street to Ivasyuka Street; the section from Ivasyuka Street between Stusa and Ioanna Pavla II Streets; the section from Ivasyuka Street to Nezalezhnosti Street; The intersection of Ivasyuka and Volchynetskaya Streets; as well as the section of Nezavisimosti Street from Mykytynetskaya Street to Iosifa Slipoho Street. Additional traffic congestion is regularly recorded on the bridge over the river on Tisemenitskaya Street, as well as at the intersections of Tisemenitskaya Street with Dekabristov and Yunosti Streets. The road surface condition on Avtolevmashevskaya Street is also assessed as unsatisfactory due to the prevalence of potholes. The authorized end point for the U-turn maneuver on this route is the Pressmash U-turn circle. The corresponding initial data for Route No. 10, connecting Rodon Public Joint-Stock Company with Pressmash, are systematized and presented in Table 2.

Based on empirical data collected during systematic monitoring of routes No 4 and No 10 during the 2022 operating period [4, 5], a set of key performance indicators was defined for a subsequent comprehensive assessment of the rolling stock's operational efficiency.

**Table 2. Initial data on route No. 10 PJSC " Rodon " – Pressmash**

Indicator name	Direct direction	Reverse direction
Route length, km	9.01	7.83
Technical speed, km/ h	28	
Number of working days, days.	365	
Number of stops, units	18	16
Zero mileage, km	0.84	0.79

Using the methodological framework outlined in [6,7], average daily operational metrics for electric rolling stock on routes No 4 and No 10 in Ivano-Frankivsk were calculated and summarized in Table 3.

**Table 3. Average daily performance indicators of electric rolling stock**

Indicator	majestic
Route	No.4
Average number of turnovers :	10
Clarification of operating hours of trolleybuses on the route	12.91 hours.
Check-in time in the outfit	14.94 hours.
Work productivity per day	5456.64 pass.
Daily productivity in passenger kilometers	12495.706 pass · km .
Productive mileage of a trolleybus	205.2 km.
Average daily trolleybus mileage	206.23 km.
Trolleybus mileage utilization rate	0.99.
Movement interval	19.4 min.
Movement frequency	3.09 cars / hour.
Route	No. 10
Average number of turnovers	10
Clarification of operating hours of trolleybuses on the route	12.68 hours.
Check-in time in the outfit	12.73 hours.
Work productivity per day	4640.58 pass.
Daily productivity in passenger kilometers	10255.7 pass · km.
Productive mileage of a trolleybus	168.4 km.
Average daily trolleybus mileage	170.03 km.
Trolleybus mileage utilization rate	0.99.
Movement interval	19.02 min.
Movement frequency	3.15 cars /hour.

Thus, based on the results of a comprehensive study of the operating parameters of electric rolling stock on routes No 4 and No 10 in Ivano-Frankivsk, the key parameters characterizing both vehicle performance and passenger load dynamics were successfully identified and quantified for both trolleybuses and electric buses.

Determination of energy consumption during the operation of rolling stock. The operational efficacy and economic viability of electric public transport systems are contingent not merely upon the intrinsic technical specifications of the rolling stock, but also, and to a significant degree, upon their specific regimes of operation during service. Substantial conservation of energy resources can be realized through the methodological optimization of velocity profiles adopted by vehicles traversing urban thoroughfares. The critical importance of this undertaking has been further accentuated by the contemporary context of markedly escalated electricity tariffs [10]. A fundamental operational constraint arises from the fact that trams and trolleybuses are typically not outfitted with onboard

electricity metering apparatus. Consequently, vehicle operators are deprived of direct feedback, precluding them from selecting a driving strategy that minimizes energy consumption. The monitoring of aggregate energy usage occurs solely at the level of the enterprise or substation, a practice that renders the precise attribution of consumption to specific vehicles, routes, or operational phases exceedingly challenging, if not entirely unfeasible. To address this analytical gap, the present investigation employs methodologies of mathematical modeling to scrutinize patterns of electricity consumption and to formulate consequent measures for energy conservation.

Scholarly inquiry into the enhancement of electric transport efficiency through motion control is fundamentally grounded in the principles of vehicle dynamics. A more nuanced approach to these issues involves their consideration from the perspective of automated electric drives engineered for specialized technological applications. A defining characteristic of this methodological framework is the formulation of the equation of motion with reference to the wheel rim, as opposed to the motor shaft, while adopting the distance traversed as the independent variable. Given that trams and trolleybuses generally operate without multi-speed gearboxes, the gear ratio linking the motor shaft to the wheel rim remains invariant, thereby rendering the first distinction less consequential in practice. However, the second distinction is of paramount importance, as time cannot be treated as a purely independent variable; the velocity and the very nature of the motion are themselves dependent variables that fluctuate dynamically in response to real-world operational conditions, such as traffic, gradients, and mandatory stops.

The foundational relationship governing the kinematics of electric rolling stock is described by the fundamental equation of electric traction theory, which provides the deterministic basis for calculating vehicle speed [11, 12]:

The basic equation of the theory of electric traction determines the speed of electric rolling stock [11, 12]:

$$28,3 \cdot (1 + \gamma_t) \cdot \frac{dV}{dt} = \frac{F_t(V)}{g \cdot M(t)} - w_o(V) - w_d(s), \quad (1)$$

where  $\gamma_t = M_i/M_t$  – inertia coefficient;

$M_t$  – total mass of the vehicle,  $t$ ;

$M_i$  – additional mass of rotating parts,  $t$  (for different types of rolling stock  $\gamma_t = 0.1-0.2$ );

$V$  – speed, km/h;

$t$  – travel time, s;

$F_t(V)$  – traction force of engines in accordance with the operating mode of the traction electric drive of the vehicle;

$M(t)$  – mass of the vehicle taking into account passengers;  $g$  – acceleration of gravity m/s<sup>2</sup>;

$w_o(V)$ ,  $w_d(s)$  – specific main and additional motion resistances [11, 12].

The main specific resistance of movement determined by the dependencies for electric buses [11, 12]

$$w_o(V) = 12 + 0,004 \cdot V^2, \quad w_d(s) = 16 + 0,004V^2. \quad (2)$$

The additional specific resistance to movement consists of resistances due to slopes  $i(s)$  and from curved sections of the path  $iR(s)$

$$w_d(s) = i(s) + iR(s). \quad (3)$$

For the precise determination of vehicular energy expenditure, this analysis adopts the methodological framework and data pertaining to the operational modes of electric rolling stock as established in the foundational study [11].

The velocity profile of an electric bus over a representative 600-meter route segment, delineating three distinct operational regimes: "Economic," "Fast," and "Intermediate." [11] The "Economic" mode is characterized by an initial traction phase spanning 150 meters, followed by an extended coasting phase, with deceleration initiated only 10 meters prior to a complete stop. In contrast, the "Fast" mode employs continuous traction for 470 meters, transitioning to braking for the final 130 meters. The "Intermediate" mode constitutes a hybrid approach, with traction applied for 250 meters before the vehicle enters a coasting state [11]. The corresponding current consumption of the traction drive, which is active exclusively during phases requiring motive power. Analysis confirms that energy draw is minimized in the "Economic" mode. Conversely, in the "Fast" mode, current is consumed for the majority of the trajectory, with a minimum observed value of 160 A. Following the obstruction, the vehicle resumes motion in an acceleration phase, with its current consumption profile mirroring that of the initial departure [11].

A quantitative analysis of specific electricity consumption, summarized in Table 4, reveals significant disparities across the operational modes. The "Fast" mode demands 143 Wh/t-km, the "Intermediate" mode 97.5 Wh/t-km, and the "Economic" mode merely 78 Wh/t-km. This data unequivocally demonstrates the profound potential for energy conservation through the strategic modulation of driving behavior. However, a critical implementation barrier exists: drivers are operationally bound to adhere to fixed schedule commitments. The designated operational speed for the trolleybus is approximately 16 km/h, with stipulated idling durations at stops ranging from 10 to 45 seconds. Crucially, simulations indicate that even when employing the "Economic" mode with the maximum permissible idling time, an operational speed of 17.56 km/h is achievable (Table 4). This exceeds the scheduled requirement, thereby proving that energy-efficient driving does not inherently compromise timetable adherence. Despite this, empirical observation suggests a driver propensity towards the "Fast" mode, a tendency largely attributable to the absence of real-time energy consumption feedback, which focuses driver attention singularly on schedule compliance [11].

**Table 4. Results of calculation of electric bus operation indicators in different driving modes**

Indicator	Driving mode			
	Economical	Intermediate	Fast	With an obstacle
Electricity consumption (travel 600m), kWh	0.77 (100%)	0.96 (125%)	1.41 (191%)	1.72 (223%)
Electricity consumption (travel 1 km), kWh $W_{1km}$	1,283	1.6	2.35	2,286
Travel time, s	78	60	54	90
Average speed on the section, km/h.	28.1	36	40	24
Specific electricity consumption in Wh/t km	78	97.5	143	175
As a percentage of "Fast"	54.6%	68.2%	100%	122%
Operating speed, km/h (in case of parking at a stop for 45 s)	17.56	20.57	21.81	16.0

Synthesis of research findings [11,12] indicates that a systematic transition from the "Fast" to the "Economic" driving regime can yield a substantial 45.4% reduction in energy costs. Accounting for route-specific variabilities and the probabilistic occurrence of obstacles, a conservative estimate for achievable electricity savings falls within the range of 10% to 45%.

According to the results of the research, the electricity costs for traveling 1 km by electric bus in the "Economical", "Fast", "Intermediate" and "Over obstacles" driving modes ( $W_{1km}$ ) were determined, which are given in Table 5.

Based on the calculations given in [ 1, 3], the performance of single-cell storage devices using only LTO cells, LFP cells and supercapacitors was determined . As an example, the LTO cells YINLONG 66160H 2.3v 40ah [13], LFP cells ENERpower 26650 LiFePO4 3.2V 3000mAh (10C) [14] and

supercapacitors Maxwell 3000 FARAD Capacitor were considered. Boostcap 3000f 2.7 volt BCAP3000 [15] taking into account the technical cost parameters of the elements based on information from [1,3].

$$W_n = W_{1km} \cdot L_m, \tag{4}$$

where  $L_m$  - the mileage of the vehicle using the energy storage device, which is determined according to the storage device usage mode when charging a – the mileage is equal to the total mileage in the forward and reverse directions.

The general energy consumption indicators of storage devices for electric buses are given in Table 5.

**Table 5. Energy capacities of storage devices for electric buses with**

Electric bus driving mode	Vehicle route	Energy capacity of the storage tank, kWh
Economical	4	52.6
Intermediate	4	65.6
Fast	4	96.4
Behind obstacles	4	117.6
Economical	10	43.2
Intermediate	10	53.8
Fast	10	79
Behind obstacles	10	96.4

The capacity of the on-board storage device must ensure the operation of electrical equipment during the operation of the traction drive and auxiliary systems.

The power at the wheels of an electric bus is determined by the resistance force according to the expression

$$P_1 = \frac{W_0 \cdot V}{3600} = \frac{(12 + 0,004 \cdot V^2) g \cdot m \cdot V}{3600}. \tag{5}$$

The storage capacity is determined taking into account the efficiency of the traction drive determined for the traction drive of the electric bus according to the dependencies shown in [20] and the efficiency of the mechanical transmission which is  $\eta_m = 0.17$  [ 11] and taking into account additional own needs (for heated trolleybuses it is  $P_d=18$  kW)

$$P_{nak} = P_1 \cdot (\eta - \eta_m) + P_d. \tag{6}$$

Results of determining the capacity of the energy storage device for operating modes are given in Table 6.

For further research, we will use elements characterized by the following technical parameters.

The number of series-connected elements is determined by

$$K_s = \frac{u_{DC}}{u_{ch}}, \tag{7}$$

where  $u_{DC}$  – is the voltage of the intermediate circuit;  
 $u_{ch}$  – is the voltage at the end of charging the element.

The resulting value  $N_s$  is rounded up.

$$x_i = \max(K_1, K_2), \quad (8)$$

where  $K_1$  – is the number of parallel branches, determined from the condition of ensuring the required level of energy accumulation;

$K_2$  –the number of parallel branches, determined from the condition of ensuring the required level of storage capacity.

**Table 6. Storage capacity for electric buses**

Driving mode	V	$w_0$	$W_0$	$P_2$	$\eta$	$\eta_m$	$\eta_{sum}$	$P_1$	$P_n$
-	km/h	H/kH	H	kW				kW	kW
Economical	50	12.78	2257	113.7	0.78	0.17	0.61	186	205
Fast	56.2	12.97	2290	128.7	0.82	0.17	0.65	197	216
Intermediate	61.2	13.15	2323	142.2	0.87	0.17	0.70	203	221
Behind obstacles	61.2	13.15	2323	142.2	0.87	0.17	0.70	203	221

The number of parallel branches, determined from the condition of ensuring the required level of energy accumulation ( $W_n$ ), is determined by the expression

$$K_1 = \frac{W_n}{K_s \cdot W_{cell} \cdot k_1}, \quad (9)$$

where  $W_{cell}$  – capacity of one element, expressed in kWh;

$k_1$  – a coefficient that takes into account the reduction in energy that an energy storage element can store when charged with a current exceeding the optimal value. According to the recommendations [3], we take it equal to 0.9. The resulting value  $N1$  is rounded up.

The number of parallel branches, determined from the condition of ensuring the required level of storage capacity, is determined by the expression

$$K_2 = \frac{P_n}{K_s \cdot u_{DC} \cdot i_{c1}}, \quad (10)$$

where  $P_n$  – nominal capacity of the storage device;

$u_{DC}$  – discharge voltage of the cell;

$i_{c1}$  – the smaller of the charge and discharge current of the cell  $i_{c1} = \min(i_1, i_2)$ .

Here  $i_1$ – permissible charging current,  $i_2$ – permissible discharging current.

The resulting value  $K_2$  is rounded up.

Number of elements

$$K_{cell} = x_i \cdot K_s, \quad (11)$$

Total mass of elements

$$M = K_{cell} \cdot M_{cell}, \quad (12)$$

where  $m_{cell}$  –is the mass of one element.

We will determine the volume required to accommodate the elements of the on-board storage device

$$v = K_{cell} \cdot x_{cell} \cdot y_{cell} \cdot z_{cell}, \quad (13)$$

where  $x_{cell}$  – length of the element;

$y_{cell}$  – width of the element;

$z_{cell}$  – height of the element.

Cost of storage elements

$$Z = K_{cell} \cdot C_{cell}. \quad (14)$$

The total capacity of the storage elements is equal to

$$W = K_{cell} \cdot W_{cell}. \quad (15)$$

General results of calculations of basic single-cell storage devices are given in [1, 2, 3].

The calculations did not take into account the volumes and masses of the cooling system components, as well as the dimensions of the battery management system.

The presented computational models explicitly omitted the volumetric, mass, and spatial contributions associated with the constituent elements of the cooling apparatus, as well as the physical dimensions of the essential battery management system.

A synthesis of comparative analyses, as documented in the referenced studies [1, 2, 3], establishes that energy storage systems predicated upon Lithium Iron Phosphate (LFP) chemistry are characterized by the most substantial mass and volumetric footprints. In direct contrast, storage systems utilizing supercapacitors demonstrate the most favorable aggregate mass characteristics, whereas configurations based on Lithium Titanate (LTO) technology necessitate the smallest installation volume. Furthermore, the lowest aggregate component cost is similarly identified for the LTO-based storage system configuration.

The total energy density realized in a single-cell-type supercapacitor storage system approximates its nominal energy density. However, a significant disparity is observed in battery-based systems: the available energy density surpasses the minimum operational requirement by a factor of approximately 5.5 for LTO cells and a substantial 14.7 for LFP cells. While the capability to recharge the energy storage system after multiple trip cycles is a favorable attribute, the pronounced underutilization of the installed energy capacity results in considerable inefficiencies, manifesting as escalated penalties in mass, volume, and capital expenditure. Among the configurations subjected to analysis, a single-cell-type system utilizing LTO chemistry provides the most advantageous total cost, whereas an LFP-based system yields the lowest specific cost per kilowatt-hour [1, 2, 3].

When subjected to a multi-criteria assessment encompassing mass, volume, total cost, and cost per kilowatt-hour, it is evident that no single-cell energy storage technology achieves a simultaneous optimization across all performance vectors. Consequently, a rationally justified engineering solution entails the implementation of a hybrid, or combined, energy storage system. Such a system is architected to synergistically amalgamate the distinct advantages inherent to the individual cell types previously considered.

The conditional optimization of the parameters for a hybrid energy storage system is formally categorized as a constrained parameter minimization problem. Informed by the foundational work of previous studies [1, 2, 3], and taking into account the inherent uncertainties associated with long-term operational and end-of-life disposal costs, the total cost of the storage system's core components was selected as the primary objective function to be minimized. This criterion provides a robust and quantifiable basis for the system's design optimization.

The objective function has the following form

$$Z = Z_{LTO} + Z_{LFP} + Z_{SC} \rightarrow \min, \quad (16)$$

where  $Z_{LTO}$  is the cost of LTO cells;  
 $Z_{LFP}$  – is the cost of LFP cells;  
 $Z_{SC}$  – is the cost of supercapacitors.

Due to the fact that the energy storage device consists of parallel branches of connected elements, it is rational to choose the number of branches of each type of storage device as parameters for the combined storage device:  $x_1$  – number of branches with LTO elements,  $x_2$  – number of branches with LFP elements,  $x_3$  – number of branches with supercapacitors.

Thus, the total cost of the elements can be determined by the expression

$$Z = x_1 \cdot Z_1 + x_2 \cdot Z_2 + x_3 \cdot Z_3 \rightarrow \min, \quad (17)$$

where  $Z_1$  - the cost of the LTO cell branch;  
 $Z_2$  - the cost of the LFP cell branch;  
 $Z_3$  - the cost of the supercapacitors branch.

Let us consider the constraints (conditions) imposed on the storage parameters and used in the conditional minimization problem.

Constraints in the form of equalities. This group of constraints includes constraints that establish the required nominal power ( $P_n$ ) and nominal energy capacity of the storage device ( $W_n$ )

$$P = P_{LTO} + P_{LFP} + P_{SC} = P_n, \quad (18)$$

where  $P_{LTO}$  – is the nominal power of LTO cells;  
 $P_{LFP}$  – is the nominal power of LFP cells;  
 $P_{SC}$  – is the nominal power of supercapacitors.

$$W = W_{LTO} + W_{LFP} + W_{SC} = W_n, \quad (19)$$

where  $W_{LTO}$  – is the operating energy capacity of LTO cells;  
 $W_{LFP}$  – is the operating energy capacity of LFP cells;  
 $W_{SC}$  – is the operating energy capacity of supercapacitors.

According to the approaches [16-20], to set the constraints in the minimization problem in the form of equalities, we transform them into inequalities in the form

$$P \geq P_n, \quad (20)$$

where  $P_n$  – the specified storage capacity.

$$W \geq W_n, \quad (21)$$

where  $W_n$  – the specified energy capacity of the storage device.

Taking into account the parameters of the storage device, we transform the dependencies (18)-(21) to the form necessary for solving the problem

$$x_1 \cdot P_1 + x_2 \cdot P_2 + x_3 \cdot P_3 \geq P_n, \quad (22)$$

where  $P_1$  – is the power of branches with LTO elements;  
 $P_2$  – is the power of branches with LFP elements;

$P_3$  – is the power of branches with supercapacitors.

$$x_1 \cdot W_1 + x_2 \cdot W_2 + x_3 \cdot W_3 \leq W_n, \quad (23)$$

where  $W_1$  – is the energy density of branches with LTO cells;

$W_2$  – is the energy density of branches with LFP cells;

$W_3$  – is the energy density of branches with supercapacitors.

Let's consider restrictions in the form of inequalities. This group includes restrictions that are set for the storage device according to mass-dimensional indicators (  $m_n$  maximum mass of storage device elements,  $V_n$  maximum volume of storage device elements), i.e.

$$M = M_{LTO} + M_{LFP} + M_{SC} \leq M_n, \quad (24)$$

where  $M_{LTO}$  – is the mass of LTO cells;

$M_{LFP}$  – is the mass of LFP cells;

$M_{SC}$  – is the mass of supercapacitors.

$$v = v_{LTO} + v_{LFP} + v_{SC} \leq v_n, \quad (25)$$

where  $v_{LTO}$  – is the volume of LTO cells;

$v_{LFP}$  – is the volume of energy capacity of LFP cells;

$v_{SC}$  – is the volume of supercapacitors.

Taking into account the parameters of the components of the combined storage device, we transform the dependencies (24), (25) to the form necessary for solving the problem

$$x_1 \cdot M_1 + x_2 \cdot M_2 + x_3 \cdot M_3 \leq M_n, \quad (26)$$

where is  $M_1$  – the mass of the LTO cell branch;

$M_2$  – is the mass of the LFP cell branch;

$M_3$  – is the mass of the supercapacitors branch.

$$x_1 \cdot v_1 + x_2 \cdot v_2 + x_3 \cdot v_3 \leq v_n, \quad (27)$$

where  $v_1$  - the volume of the LTO-element branch;

$v_2$  - the volume of the LFP-element branch;

$v_3$  - the volume of the supercapacitors branch.

In addition to constraints in the form of equalities and inequalities according to the approaches [10-12], we set constraints on the parameters of the optimization problem

$$\begin{cases} x_{1min} \leq x_1 \leq x_{1max}; \\ x_{2min} \leq x_2 \leq x_{2max}; \\ x_{3min} \leq x_3 \leq x_{3max}, \end{cases} \quad (28)$$

where  $x_{1min}$  – the minimum number of branches of LTO elements;

$x_{1max}$  – the maximum number of branches of LTO elements;

$x_{2min}$  – the minimum number of branches of LFP elements,

$x_{2max}$  – the maximum number of branches of LFP elements;

$x_{3min}$  – the minimum number of branches of supercapacitors;

$x_{3max}$  – the maximum number of branches of supercapacitors.

To address the formulated conditional minimization problem, the computational procedures were executed within the MATLAB software environment (developed in the United States), utilizing the specialized OptLab optimization toolkit (developed in Ukraine). This specific software combination was selected for its capacity to provide access to an extensive suite of algorithmic methods suitable for the problem class at hand. Following preliminary trials with a constrained set of test solutions, it was determined that the most efficacious results were yielded through the application of the Weyl method, particularly when initiated from a variety of distinct initial search points within the solution space.

The present study is therefore dedicated to resolving the optimization problem of identifying optimal configurations for combined (hybrid) energy storage systems across a spectrum of requisite energy and power capacities. These capacity requirements are not fixed but are dynamically determined by a complex set of operational variables. These include specific vehicle driving modes, the topographical profile and spatial trajectory of the route, and the loading parameters of the rolling stock. The foundational data and operational constraints for these plug-in hybrid power plants for electric buses are derived from the established research presented in works [1,2,3].

The complete iterative process and trajectory for solving these configuration optimization problems for the combined energy storage system are documented in detail in Fig 1-4. The graphical representations therein illustrate the solution paths, wherein the initial starting point for the optimization algorithm is explicitly marked by a circular dot, and the final, converged optimal solution is indicated by a rhombus symbol.

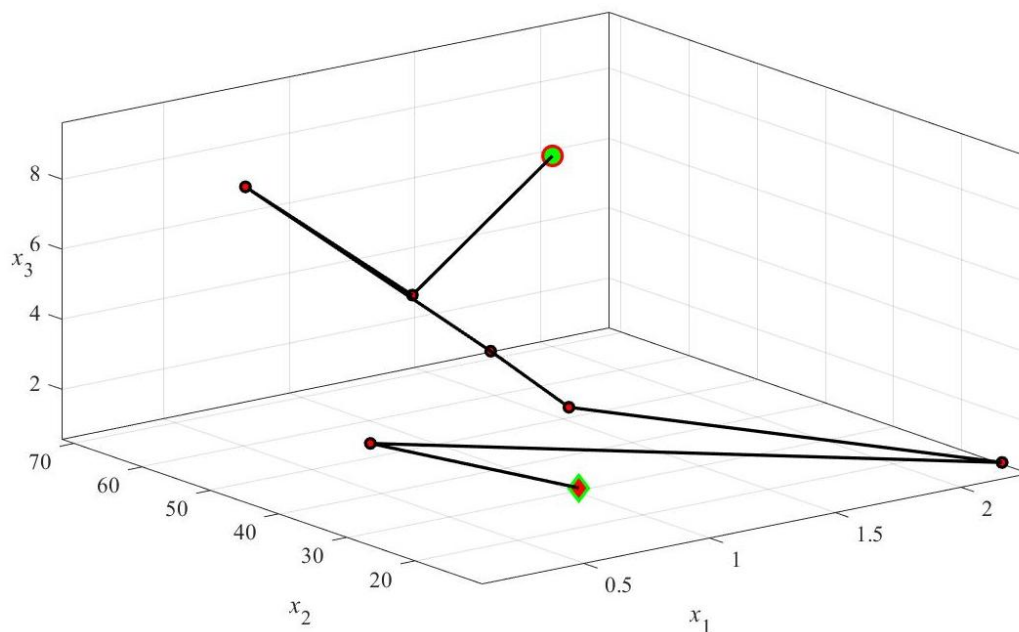

**Fig. 1. The progress of solving the problem of optimizing the parameters of the energy storage device at a given maximum energy capacity of 52.6 kWh and power 205 kW and energy consumption 43.2 kWh and power 205 kW**

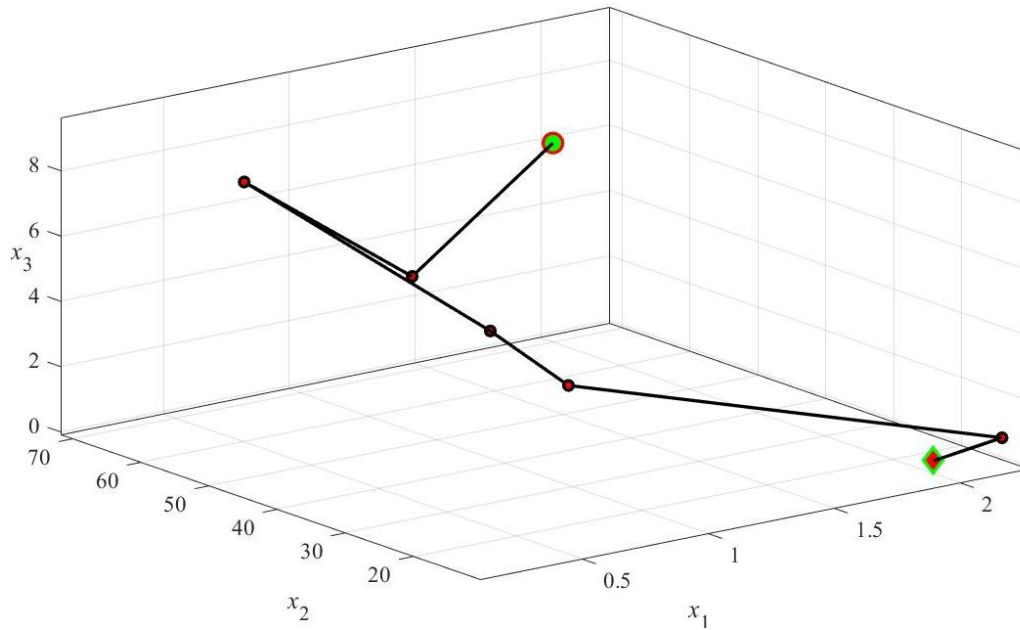

**Fig. 2.** The progress of solving the problem of optimizing the parameters of the energy storage device at a given maximum energy capacity of 65.6 kWh and power 216 kW and energy consumption 53.8 kWh and power 216 kW

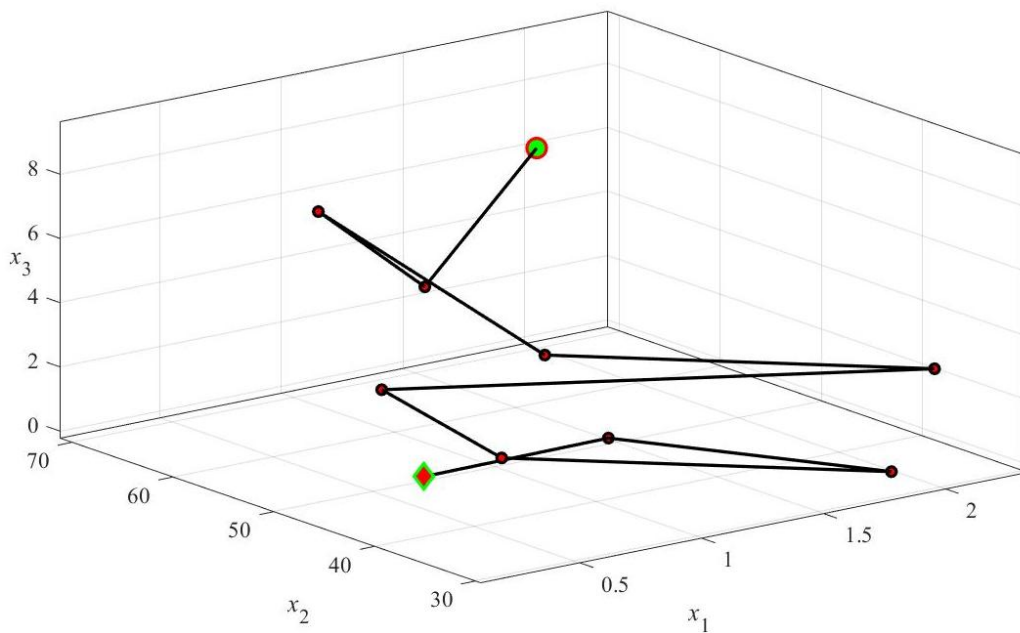

**Fig. 3.** The progress of solving the problem of optimizing the parameters of the energy storage device at a given maximum energy capacity of 96.4 kWh and power 221 kW and energy intensity 79 kWh and power 221 kW

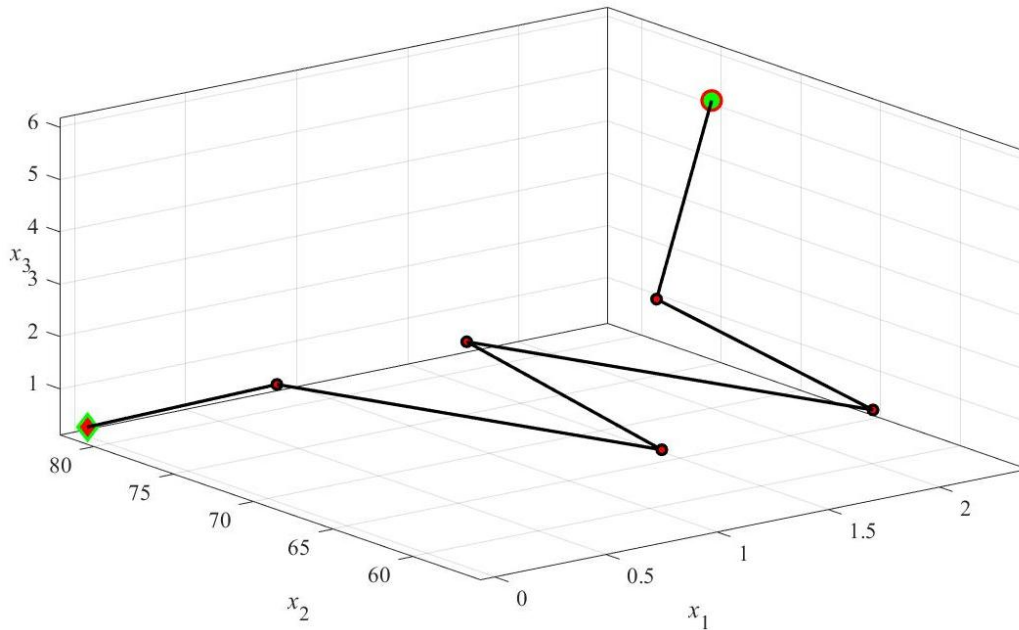

**Fig. 4. The progress of solving the problem of optimizing the parameters of the energy storage device at a given maximum energy capacity of 117.6 kWh and power 221 kW and energy consumption**

The overall results are presented in Tables 7.

**Table 7. Results of solving the problem of finding optimal parameters of the energy storage device when charging an electric bus at terminal stops**

Route	$W_n$	$P_n$	$x_1$	$x_2$	$x_3$	$P$	$W$	$M$	$v$	$Z$
-	kWh	kW	-	-	-	kW	kWh	t	m <sup>3</sup>	thousand euros
4	52.6	205	1	28	1	210	74	0.89	0.52	50.91
4	65.6	216	2	15	0	230	71.5	0.883	0.49	52, 49
4	96.4	221	1	47	0	226	107	1.09	0.57	54.44
4	117.6	221	0	81	0	228	146	1.32	0.67	57.83
10	43.2	205	1	28	1	210	74	0.89	0.52	50.91
10	53.8	216	2	15	0	230	71.5	0.883	0.49	52.49
10	79	221	1	47	0	226	107	1.09	0.57	54.44
10	96.4	221	1	47	0	226	107	1.09	0.57	54.44

The assessment of specific indicators of storage tanks is given in Table 8 .

The implementation of an energy storage system for electric bus operation under an opportunity-charging paradigm at equipped terminal stops for routes 4 and 10 reveals that optimal configurations span single-, dual-, and triple-component system architectures. For an economical driving regime on both routes, the optimal configuration is identified as a three-component storage device, comprising 1 branch of LTO cells, 28 branches of LFP cells, and 1 branch of supercapacitors.

Conversely, for intermediate and high-speed driving modes, the optimal solutions shift to dual-component architectures. Specifically, the intermediate mode is best served by a configuration of 2 branches with LTO cells and 15 branches with LFP cells, while the high-speed mode necessitates a system of 1 branch with LTO cells and 47 branches with LFP cells. Under an "obstacle" mode, which simulates demanding traffic conditions, the operational requirements for route 10 can be met by a storage device configured for the "high-speed" regime. However, for route 4, which exhibits a higher energy

demand profile, a more substantial, mono-component storage device based exclusively on LFP elements, comprising 81 branches, is required.

**Table 8. Results determination specific indicators of energy storage devices when charging an electric bus at terminal stops**

Route	Electric bus driving mode	$x_1$	$x_2$	$x_3$	$P_u$	$W_u$	$M_u$	$v_u$
-	-	-	-	-	thousand euros /kW	thousand euros / kWh	thousand euros /t	thousand euros /m <sup>3</sup>
4	Economical	1	28	1	0.242	0.688	57.202	97.904
4	Intermediate	2	15	0	0.228	0.734	59.445	107.122
4	Fast	1	47	0	0.241	0.509	49.945	95.509
4	Behind obstacles	0	81	0	0.254	0.396	43.811	86.313
10	Economical	1	28	1	0.242	0.688	57.202	97.904
10	Intermediate	2	15	0	0.228	0.734	59.445	107.122
10	Fast	1	47	0	0.241	0.509	49.945	95.509
10	Behind obstacles	1	47	0	0.241	0.509	49.945	95.509

A critical finding of this analysis is that, due to the reduced absolute energy consumption inherent in this operational model, the primary determinant of storage device parameters shifts to power delivery capability. The installed energy capacity for most driving modes consequently represents a significant over-provisioning, with the exception of the "obstacle" mode, where both energy and power are coequally significant constraints. This over-provisioning is quantified as follows: energy capacity exceeds the minimum requirement by 40.7% and 71.2% for routes 4 and 10, respectively, in the economical mode; by 9% and 32.9% in the intermediate mode; and by 11% and 35.4% in the high-speed mode.

The mass of the optimally sized storage devices for this charging strategy is substantially lower - by a factor of 2.4 to 4.14 - compared to the mass of systems designed for depot charging, ranging from 0.89 tonnes to 1.32 tonnes. Correspondingly, the cost of the constituent cells is also significantly reduced, amounting to 50.91 and 57.83 thousand euros, which is 1.84 to 4.41 times lower than the cost of cells required for depot-charging scenarios.

The specific cost metrics for the derived optimal storage device parameters fall within a range of 0.228 to 0.254 thousand euros per kilowatt-hour for specific power, and 0.396 to 0.734 thousand euros per kilowatt-hour for specific energy. This cost structure is directly attributable to the predominant utilization of branches equipped with LFP elements in the final configurations.

**Assessment of shortcomings and prospects for the development of the above research.** When optimizing the parameters of energy storage devices for electric buses, the main drawback is not taking into account the transient processes of the multi-component energy storage device during the movement of the electric bus along the route. Significant energy flows between components and the rate of energy exchange between cells of different types significantly depend on the type of semiconductor control converter and the modes of movement of the electric bus. Therefore, the main direction of further research may be the determination of the parameters and modes of operation of the multi-component semiconductor converter control system.

**Conclusions.** When using an energy storage device for an electric bus when charging an electric bus at the final equipped stop on routes 4 and 10, it is also optimal to use a single-, two-component and three-component type of storage device. So, for economical movement on routes 4 and 10, three-component storage devices with 1 branch with LTO cells and 28 branches with LFP cells and 1 branch of supercapacitors are optimal. When moving in intermediate and high-speed modes, two-component

storage devices with the following parameters are optimal: 2 branches with LTO cells and 15 branches with LFP cells and 1 branch with LTO cells and 47 branches with LFP cells, respectively. For the obstacle mode, a storage device operating in the "high-speed" mode is sufficient for route 10, however, for route 4, which requires higher energy consumption, it is necessary to use a mono-component LFP - an element storage device with 81 branches. Due to the reduction in energy consumption requirements, the main factor determining the storage device parameters is power, and the energy consumption for such modes of operation of the electric bus is excessive except for the "obstacle" mode, where both factors are significant. Thus, the energy consumption in the economic mode exceeds the minimum required for 4 and 10 by 40.7% and 71.2%, respectively, for the "Intermediate" mode by 9% and 32.9%, and for the "High-speed" mode by 11% and 35.4%. The mass of the storage device is significantly less (2.4-4.14 times) than the mass of an electric bus when charging at a depot and ranges from 0.89 t to 1.32 t. As for the cost of the cells, their cost is 50.91 and 57.83 thousand euros, which is significantly lower than the cost of cells (1.84 – 4.41 times) when charging an electric bus at a depot.

## REFERENCES

1. Kondratyeva, L. Yu., & Ryabov, E. S. (2022). Preliminary analysis of options for building an on-board energy storage system for an electric locomotive. *Theoretical and practical research of young scientists: proceedings of the XVI International Scientific and Practical Conference of Master's and PhD Students* (p. 421). Kharkiv: NTU "KhPI". [https://science.kname.edu.ua/images/dok/konferentsii/2025/Tezi%20konferencij%202025/Materiali\\_KONFERENCIA\\_2\\_24\\_ZOVTNA\\_2025.pdf](https://science.kname.edu.ua/images/dok/konferentsii/2025/Tezi%20konferencij%202025/Materiali_KONFERENCIA_2_24_ZOVTNA_2025.pdf). [in Ukrainian]
2. Kondratieva, L., Overianova, L., Tkachenko, V., Riabov, I., & Demydov, O. (2024). Simulation of the operation of the on-board energy storage in the traction system of a quarry locomotive. *Transport Systems and Technologies*, (43), 136–148. <https://doi.org/10.32703/2617-9059-2024-43-11>.
3. Goolak, S., Kondratieva, L., Riabov, I., Keršys, A., & Makaras, R. (2023). Research and optimization of hybrid on-board energy storage system of an electric locomotive for quarry rail transport. *Energies*, 16(7), 3293. <https://doi.org/10.3390/en16073293>.
4. [Qualification work]. (n.d.). *ELARTU Institutional Repository of Ternopil Ivan Puluj National Technical University*. Retrieved from: <https://elartu.tntu.edu.ua/bitstream/lib/43534/2/Кваліфікаційна%20робота.pdf>. [in Ukrainian]
5. Babiy, M. V., Dolynnyi, A. V., & Kostyuk, E. R. (2019). Setting the main tasks of organizing trolleybus transportation. *Proceedings of the VIII International Scientific and Technical Conference of Young Scientists and Students "Actual Problems of Modern Technologies"* (vol. 1, pp. 159–160). Ternopil: TNTU. <http://elartu.tntu.edu.ua/handle/lib/30758>. [in Ukrainian]
6. KP "Electroavtotrans". (n.d.). *Official website*. Retrieved from: <http://eat.if.ua/>. [in Ukrainian]
7. Hnatov, A., Argun, Sch., & Bykova, Ye. (2016). Electric bus on supercapacitors for urban transportation. *Bulletin of the Kharkiv National Automobile and Road University*, (72), 29–34. <https://europub.co.uk/articles/-A-164844>. [in Ukrainian]
8. *Vehicle Emission Standards*. (2016). Retrieved September 3, 2018, from: <https://infrastructure.gov.au/vehicles/environment/emission/index.aspx>.
9. Khaustov, O. (2025). Choosing the type of cells for a multi-component energy storage system for an electric bus that is charged at a depot. *Energy saving. Energy. Energy audit*, 9(212), 41–56. <https://doi.org/10.20998/2313-8890.2025.09.04>. [in Ukrainian].
10. National Commission for State Regulation in the Spheres of Energy and Utilities. (2015, February 26). *On Setting Tariffs for Electricity Sold to the Population* (Resolution of the National Commission for State Regulation in the Spheres of Energy and Utilities No. 220). <https://zakon.rada.gov.ua/laws/show/z0231-15#Text>. [in Ukrainian]
11. Soroka, K. O., & Lychov, D. O. (2017). Increasing the efficiency of electric transport operations through control and optimization of speed regimes. *Bulletin of NTU "KhPI"*, 27(1249), 289–293. [in Ukrainian]
12. Soroka, K. O., & Lychov, D. O. (2015). Meaningful model and equations of electric transport movement. *Bulletin of the Dnipropetrovsk National University of Railway Transport*, 3(57), 97–106. <https://doi.org/10.15802/stp2015/46056>. [in Ukrainian].
13. Yinlong Energy. (n.d.). *Yinlong battery*. Retrieved from: <https://www.yinlong.energy/yinlong-battery#footer>.
14. Enerprof. (n.d.). *Enerpower 26650 LiFePO4 3.2V 3000mAh 10C*. Retrieved from: <https://enerprof.de/en/lifepo4-batteries/lifepo4-battery-cells/lifepo4-battery-cells-26650/36/enerpower-26650-lifepo4-3.2v-3000mah-10c>.
15. Maxwell Technologies. (2021). *New 2.7V 3000F Cell Datasheet*. Retrieved from: [https://maxwell.com/wp-content/uploads/2021/09/3003279.2\\_Final-DS\\_New-2.7V-3000F-Cell\\_20210406.pdf](https://maxwell.com/wp-content/uploads/2021/09/3003279.2_Final-DS_New-2.7V-3000F-Cell_20210406.pdf).
16. Nikulina, O. M., Severyn, V. P., & Kotsiuba, N. V. (2020). Development of information technology for optimizing the control of complex dynamic systems. *Bulletin of the National Technical University "KhPI". Series: System Analysis, Management and Information Technologies*, 2(4), 63–69. <https://repository.kpi.kharkov.ua/handle/KhPI-Press/50285>. [in Ukrainian].

17. Severyn, V. P., & Nikulina, O. M. (2023). *Methods and algorithms of multidimensional unconditional optimization: a textbook*. Kharkiv: NTU "KhPI". <https://repository.kpi.kharkov.ua/handle/KhPI-Press/67856>. [in Ukrainian].
18. Nikulina, O. M., & Severyn, V. P. (2024). *Numerical methods for modeling and optimization of control of dynamic systems: a textbook*. Kharkiv: NTU "KhPI". <https://repository.kpi.kharkov.ua/handle/KhPI-Press/73689>. [in Ukrainian].
19. Liubarskyi, B., Iakunin, D., Nikonov, O., Liubarskyi, D., & Yeritsyan, B. (2022). Optimizing geometric parameters for the rotor of a traction synchronous reluctance motor assisted by partitioned permanent magnets. *Eastern-European Journal of Enterprise Technologies*, 2(8(116)), 38–44. <https://doi.org/10.15587/1729-4061.2022.254373>.
20. Khaustov, O., & Liubarskyi, B. (2025). Optimization of quasi-steady-state operating modes of synchronous jet motors with permanent magnets for electric buses. *Energy saving. Energy. Energy audit*, 3(206), 16–30. <https://doi.org/10.20998/2313-8890.2025.03.02>. [in Ukrainian].

### **Олександр Хаустов<sup>1</sup>, Борис Любарський<sup>2</sup>**

<sup>1</sup>Аспірант, Кафедра електричного транспорту та тепловозобудування, Національний технічний університет «Харківський політехнічний інститут», вул. Кирпичова, 2, м. Харків, Україна, 61002, Україна. ORCID: <https://orcid.org/0009-0001-0363-6173>.

<sup>2</sup>Професор, Кафедра електричного транспорту та тепловозобудування, Національний технічний університет «Харківський політехнічний інститут», вул. Кирпичова, 2, м. Харків, Україна, 61002, Україна. ORCID: <https://orcid.org/0000-0002-2985-7345>.

### **Оптимізація параметрів накопичення енергії електробусів, що заряджаються на кінцевих зупинках**

**Анотація.** В роботі розроблено методологію визначення оптимальних параметрів комбінованого накопичувача енергії для електробуса на основі вирішення задачі умовної мінімізації з урахуванням режиму руху, параметрів маршруту, та обмежень за вагою та розмірами при заряджанні накопичувача на кінцевих зупинках маршруту. Практичне значення роботи полягає у визначенні параметрів комбінованих накопичувачів енергії для електробуса на прикладі багатокомпонентного накопичувача енергії. Аналіз результатів дослідження щодо вирішення задачі оптимізації довів, що при економічному русі на маршруті 4 та 10 оптимальними є трикомпонентні накопичувачі з 1 гілкою з LTO-елементами та 28 гілок з LFP – елементами та 1 гілкою суперконденсаторів. При русі у проміжному та швидкісному режимах оптимальними є двокомпонентні накопичувачі з параметрами: 2 гілки з LTO-елементами та 15 гілок з LFP – елементами та 1 гілка з LTO-елементами та 47 гілок з LFP – елементами, відповідно. Для режиму з перешкодами для 10 маршрути достатньо накопичувача, що працює у «швидкісному» режимі, однак для 4 маршруту, що вимагає більшої енергоємності необхідно застосування моно компонентного LFP – елементного накопичувача з 81 гілкою.

**Keywords:** тяговий привод, накопичувач енергії, електробус, тролейбус, оптимізація параметрів, цільова функція.

Дата першого надходження статті до видання 01.10.2025

Дата прийняття до друку статті 20.11.2025

**Olga Petrychenko<sup>1\*</sup>, Igor Burmaka<sup>2</sup>, Alla Vynohradova<sup>3</sup>, Tymur Stoliaryk<sup>4</sup>**

<sup>1</sup>Doctor of Philosophy, head of the Ship's handling department, National University "Odessa Maritime Academy", 8, Didrikhson str., Odessa, 65052, Ukraine. ORCID: <https://orcid.org/0009-0003-1294-2740>.

<sup>2</sup>Doctor of Technical Science, professor, Director of the Institute of Navigation, National University "Odessa Maritime Academy", 8, Didrikhson str., Odessa, 65052, Ukraine. ORCID: <https://orcid.org/0009-0005-9069-7378>.

<sup>3</sup>Leading Specialist of the Institute of Navigation, National University "Odessa Maritime Academy", 8, Didrikhson str., Odessa, 65052, Ukraine. ORCID: <https://orcid.org/0009-0006-3274-716X>.

<sup>4</sup>Doctor of Philosophy, National University "Odessa Maritime Academy", 8, Didrikhson str., Odessa, 65052, Ukraine. ORCID: <https://orcid.org/0000-0002-2922-9728>.

\*Corresponding author: [opetrychenko@gmail.com](mailto:opetrychenko@gmail.com).

### **Structural crisis in contemporary higher education: a systemic approach to institutional resilience and transformation**

*This study aims to identify current problems and trends in the development of university education, with an emphasis on sectoral educational institutions through a systematic approach to the analysis of the educational process. The methodological framework combines systemic and comparative analysis for a comprehensive study of maritime higher education as an integral component of the overall training system. A content analysis of scientific publications was conducted along with a statistical analysis of official data from four leading maritime universities in Ukraine for 2020-2024, including recruitment dynamics and admission structure by specialization. The scientific novelty lies in the comprehensive analysis of specific challenges facing maritime education, including unique problems such as restrictions on maritime practice due to port blockades, the need to adapt to international standards in the face of limited resources, and the changing perception of maritime professions in the face of wartime risks. The practical significance lies in the development of specific recommendations for overcoming crisis phenomena, including the creation of sustainable distance learning systems, the development of international partnerships and the implementation of innovative approaches to learning in conditions of limited opportunities. The study findings emphasize the strategic importance of maritime education for national security and the need to develop a comprehensive development strategy.*

**Keywords:** *educational issues, educational programs, digital transformation, student mental health, quality assessment, maritime universities, declining enrollment rates*

**Introduction.** The modern university finds itself at a critical juncture, confronting an unprecedented confluence of challenges that fundamentally question its traditional role, mission, and organizational structure. The rapid pace of technological development, demographic shifts, economic pressures, and geopolitical instability have created an environment of persistent uncertainty that permeates all aspects of higher education institution functioning worldwide. This multifaceted crisis extends beyond temporary disruptions and encompasses fundamental questions about university identity, purpose, and sustainability in an increasingly interconnected yet fragmented global landscape.

The traditional conception of the university as a sanctuary for knowledge preservation and transmission is being challenged by demands for market-oriented education, technological disruptions, and the commodification of learning. Universities simultaneously face pressure to maintain their historical role as centers of cultural preservation and intellectual development while adapting to imperatives of global competitiveness, employment-oriented curricula, and digital transformation. This tension creates a profound identity crisis manifesting in various forms: the struggle between academic

excellence and commercial viability, the balance between local cultural relevance and international standardization, the challenge of preserving humanistic values while embracing technological innovation [1].

Globalization has emerged as the most transformative force reshaping higher education, bringing both unprecedented opportunities for international collaboration and significant threats to institutional autonomy and cultural diversity. The dominance of English-language publications, standardized international rankings, and Western educational models creates pressures toward homogenization that may undermine the unique contributions of diverse educational traditions. Universities face the paradoxical challenge of achieving global recognition while preserving their distinctive cultural and intellectual identities.

The demographic crisis affecting many regions has created additional pressure on university sustainability, as declining birth rates and migration trends reduce the traditional pool of prospective students. This demographic shift coincides with economic challenges constraining public funding for higher education, forcing universities to seek alternative revenue sources and often leading to intensified commercialization of educational services. The resulting financial pressures create tensions between educational quality and economic sustainability, frequently compromising the university's ability to fulfill its broader social and cultural missions.

The rapid advancement of digital technologies has fundamentally transformed the landscape of knowledge access and dissemination, challenging traditional pedagogical approaches and raising questions about the added value of formal higher education. The proliferation of online learning platforms, massive open online courses (MOOCs), and alternative credentialing systems has democratized access to information while simultaneously undermining the university's monopoly on knowledge transmission. This technological disruption requires universities to reconceptualize their role from information providers to facilitators of critical thinking, research, and intellectual community.

Student mental health challenges have reached critical levels, reflecting broader societal pressures and the psychological impact of living in an era of constant change and uncertainty. The traditional academic environment, designed for a different generation and social context, frequently fails to meet the complex psychological needs of contemporary students who face unprecedented levels of anxiety, depression, and social isolation [2]. These challenges are intensified by the impact of global crises, including pandemics, climate change, and geopolitical conflicts, which create additional layers of stress and uncertainty.

Assessment and accountability mechanisms imposed on universities increasingly emphasize quantitative metrics that may not capture the full spectrum of educational value and social impact. This focus on measurable outcomes often leads to a reductionist approach to education that privileges easily quantifiable achievements over the development of critical thinking, cultural understanding, and civic engagement. The resulting bureaucratization of academic work diverts resources and attention from core educational and research activities, creating additional stress for faculty and administrators.

The erosion of public trust in expertise and scientific authority represents another significant challenge for universities, which have historically served as guardians of knowledge and arbiters of truth. In an era of information overload and deliberate disinformation, universities must navigate the complex task of maintaining their authority while simultaneously acknowledging the limitations of knowledge and the importance of intellectual humility.

This comprehensive analysis examines these interconnected challenges through a systemic approach that recognizes the complex interactions among various factors affecting contemporary higher education. By exploring the multifaceted nature of the current crisis, this study aims to provide insights into the fundamental transformations necessary for universities to maintain their relevance and effectiveness in an uncertain global environment. The research focuses particularly on how higher education establishments can preserve their core functions of knowledge creation, cultural transmission, and social development while adapting to the demands of an increasingly complex and rapidly changing world.

The urgency of addressing these challenges extends beyond the immediate concerns of higher education systems and encompasses broader questions of social cohesion, cultural continuity, and democratic governance [3]. Universities play a crucial role in preparing future leaders, preserving cultural heritage, and generating knowledge necessary for addressing global challenges. Their capacity to fulfill these functions while navigating current uncertainties will significantly influence the trajectory of human civilization in the coming decades.

**Analysis of Recent Research and Problem Statement.** The contemporary Ukrainian university operates under conditions of profound financial crisis, representing one of the most serious threats to preserving its status as a full-fledged participant in the global educational space. Chronic underfunding by the state creates systemic distortions across all spheres of university activity, from material and technical provision to personnel policy.

State funding for higher education in Ukraine in recent years has constituted less than one percent of gross domestic product, a critically low indicator even by developing country standards. This situation compels universities to seek alternative revenue sources; however, opportunities for financing diversification remain limited due to economic instability in the country and the absence of developed public-private partnership mechanisms in the educational sphere.

Resource insufficiency particularly acutely affects the renewal of universities' material and technical base. Obsolete laboratory equipment, absence of modern research instruments, and limited access to digital resources create a chasm between Ukrainian universities and their foreign counterparts. This problem not only diminishes educational process quality but also renders Ukrainian science less competitive at the international level.

The personnel crisis, caused by low salary levels for faculty and researchers, leads to mass migration of talented scholars abroad. The impossibility of ensuring dignified working conditions and career development prospects makes Ukrainian universities unattractive to both young specialists and experienced scholars. This creates a vicious cycle wherein declining quality of personnel potential leads to further deterioration of university reputation and reduction of its capacity to attract additional resources.

Limited financial resources also affect universities' ability to maintain international cooperation and academic mobility. Absence of funds for participation in international projects, conferences, and exchange programs gradually isolates the Ukrainian university from global scholarly networks. This is particularly critical in an era when university success largely depends on its integration into the international academic community.

Budgetary constraints force universities to reduce expenditures on research activity, negatively affecting their capacity to generate new knowledge and innovations. Insufficient funding for fundamental research undermines the long-term competitiveness of Ukrainian universities and their role in the national innovation system. Simultaneously, opportunities diminish for developing applied research that could become a source of additional income through industrial collaboration [4].

Financial difficulties also limit universities' possibilities to invest in digital infrastructure development and implementation of innovative educational technologies. In a time of rapid online education development and blended learning formats, Ukrainian universities risk falling behind global trends due to inability to ensure the necessary level of technological equipment.

The deepening financial crisis under martial law conditions creates additional challenges for the university system. Growing expenditures on security provision, the necessity of evacuation and restoration of damaged infrastructure, as well as declining student numbers due to mobilization and emigration further complicate universities' financial situation. This situation demands rethinking of traditional approaches to higher education financing and searching for new models of sustainable university development under resource-constrained conditions [5].

### **Outdated curricula and the need for updating.**

The misalignment of Ukrainian university curricula with contemporary labor market demands and global educational standards constitutes a serious obstacle to integrating the national higher education system into the global educational space. Many existing educational programs were developed decades ago and have since undergone only cosmetic changes, failing to account for fundamental transformations in science, technology, and social life.

The inertia of the university system manifests in the preservation of traditional approaches to knowledge structuring that often fail to correspond to the interdisciplinary nature of contemporary problems. The rigid departmental structure of universities and conservatism of the academic community create resistance to implementing innovative educational programs that combine different fields of knowledge. This is particularly critical in an era when the most promising directions of scientific and technological development are found at the intersection of traditional disciplines.

The lag of educational program content behind the contemporary level of scientific development results in graduates of Ukrainian universities often finding themselves unprepared for work in rapidly changing technological environments. This manifests especially acutely in information technology, biotechnology, environmental sciences, and other dynamically developing spheres where the knowledge renewal cycle constitutes only several years.

Insufficient attention to developing so-called soft skills or twenty-first century competencies leaves graduates uncompetitive in the modern labor market. Critical thinking, creativity, collaboration capacity, communication skills, and digital literacy often remain beyond the attention of traditional curricula, which focus predominantly on transmitting factual knowledge.

The absence of flexible mechanisms for curriculum renewal renders Ukrainian universities incapable of responding rapidly to changes in science and technology [6]. Bureaucratic procedures for approving new courses and programs can last years, which under conditions of exponential development in certain knowledge domains makes such programs obsolete even before their official implementation.

Insufficient engagement of employers and industry representatives in curriculum development and renewal processes leads to a disconnect between university education and real economic needs. The absence of systematic dialogue between the academic community and business environment impedes creation of educational programs that genuinely correspond to contemporary labor market requirements.

Limited opportunities for introducing innovative learning formats, such as project-based learning, research-based learning, or dual education, confine Ukrainian universities within the traditional lecture-seminar system framework. This system, while having its advantages, is not always effective for forming practical skills and competencies necessary in the modern world.

The problem of outdated curricula is further complicated by the insufficiency of qualified faculty who possess contemporary knowledge and teaching methodologies. Low levels of academic mobility and limited opportunities for professional development result in a significant portion of the teaching staff lacking adequate familiarity with the latest trends in their fields.

International rankings and quality assessment systems increasingly consider the currency and relevance of curricula, placing Ukrainian universities at a disadvantage compared to their foreign competitors. The lag in curriculum renewal negatively affects the international reputation of Ukrainian higher education and reduces the attractiveness of Ukrainian universities to foreign students and partners.

### **Student Mental Health Problems.**

The contemporary Ukrainian university confronts an unprecedented mental health crisis among student youth, which has assumed particularly acute forms under the influence of military operations, socioeconomic instability, and fundamental changes in the educational process. This crisis extends far beyond traditional academic problems and affects fundamental aspects of psychological wellbeing for an entire generation.

The impact of war on students' mental state manifests in multiple forms of traumatization, from direct combat experience to chronic stress from constant threat and uncertainty. Students who were forced to leave their homes, lost loved ones, or witnessed the destruction of familiar life demonstrate symptoms of post-traumatic stress disorder, depression, and anxiety states. Even those not directly affected by military actions experience secondary traumatization through constant informational pressure and an atmosphere of general tension [7].

The unstable global political situation intensifies feelings of uncertainty about the future among student youth. Global crises, economic fluctuations, environmental threats, and social conflicts create an atmosphere of chronic anxiety that is particularly acutely perceived by young people at the stage of forming life plans and career strategies. This leads to growing levels of nervousness, apathy, and pessimistic moods among students.

The mass transition to online education, while becoming a necessary solution under pandemic and martial law conditions, created new challenges for student mental health. Social isolation characteristic of distance learning has disrupted traditional forms of academic interaction and student community. The absence of direct contact with instructors and classmates, limited opportunities for informal communication and collective activity create feelings of alienation and loneliness.

Digital fatigue caused by prolonged time before computer and smartphone screens has become a serious problem for students' physical and mental health. Sleep pattern disruption, decreased physical activity, problems with attention concentration and learning motivation are typical consequences of intensive digital technology use in the educational process. The blurring of boundaries between personal space and learning environment complicates maintenance of a healthy balance between study and rest.

Economic instability and rising cost of living create additional stress factors for students and their families. The necessity of combining study with work to meet basic needs, absence of financial support and employment prospects after university graduation intensify anxiety and uncertainty about the future. This is particularly relevant for students from low-income families who often must abandon higher education due to financial difficulties.

Insufficient psychological support in the university environment renders students vulnerable to developing serious mental disorders [8]. Most Ukrainian universities lack sufficiently developed psychological assistance services, and existing resources often fail to correspond to the scale and complexity of problems students face. Stigmatization of mental disorders in society also prevents students from seeking professional help.

Academic pressure combined with personal crises leads to growing cases of academic burnout among students. Perfectionism, competition for scholarships and postgraduate positions, fear of failure and parental disappointment create a toxic environment that undermines not only academic achievement but also the general wellbeing of young people.

The influence of social media and the digital environment on formation of students' self-esteem and worldview creates additional risks for mental health. Constant self-comparison with others, cyberbullying, information overload, and digital technology dependence become increasingly common problems among university youth.

Student mental health problems have far-reaching consequences not only for individual wellbeing but also for educational process quality and future societal development. Growing levels of mental disorders among student youth threaten the loss of an entire generation of talented and educated citizens capable of contributing to national and global community development.

### **The Growing Commercialization of Education and Its Consequences.**

The progressive commercialization of Ukrainian higher education fundamentally transforms the nature of the university as an institution, converting it from a center of knowledge accumulation and transmission into an enterprise oriented toward profit generation. This process, while having certain positive aspects in terms of enhanced efficiency and competitiveness, simultaneously creates serious threats to the fundamental values of the academic community.

The transformation of the student into a client of educational services leads to distortion of relationships between instructor and learner. Market logic, which presupposes satisfaction of consumer needs, often contradicts the educational mission of the university, which consists not only in providing knowledge but also in forming critical thinking and intellectual personality development. This may lead to lowering of academic standards for the sake of preserving student enrollment and ensuring university financial stability.

Profit orientation prompts universities to prioritize popular and commercially attractive specializations at the expense of fundamental sciences and humanities disciplines that possess long-term societal significance but do not always ensure rapid return on investment. This leads to imbalance in personnel training and may negatively affect the cultural and intellectual development of society.

The commercialization of research activity, while potentially facilitating innovative development and technology transfer, simultaneously creates risks for research independence. Pressure from commercial partners may influence research topic selection, methodology, and even result interpretation. This is particularly problematic for research in healthcare, ecology, and social sciences, where commercial interests may contradict the public good.

Rising education costs resulting from commercialization create additional barriers to quality higher education access for representatives of less affluent population segments. This intensifies social inequality and transforms higher education into a privilege of wealthy classes, contradicting democratic society principles and potentially resulting in talented personnel loss due to socioeconomic circumstances.

The corporatization of university management, which often accompanies commercialization processes, leads to diminished role of the academic community in strategic decision-making. The dominance of managerial approaches over academic ones may lead to decisions that, while economically expedient, contradict the educational and scientific mission of the university.

The marketization of the educational process prompts universities toward aggressive promotion of their services, which may lead to exaggeration of educational program quality and graduate employment prospects. Such practices not only mislead prospective students and their parents but also undermine trust in the university system generally. [9]

Competition among universities for students and funding, while potentially stimulating quality improvement in educational services, may simultaneously lead to unhealthy rivalry and duplication of efforts instead of cooperation and coordination in developing the national higher education system.

Commercial logic often contradicts long-term university education goals such as civic consciousness formation, cultural transmission, and critical comprehension of societal processes. Focus on short-term commercial results may lead to neglect of these important university functions.

University dependence on commercial revenues renders them vulnerable to economic fluctuations and market condition changes. Financial crises may lead to sharp reductions in educational and research program funding, negatively affecting education quality and university operational stability.

The internationalization of educational services as one commercialization aspect may lead to loss of national educational program specificity and orientation toward international standards that do not always correspond to national economy and culture needs. This creates risks of cultural unification and loss of unique Ukrainian higher education traditions.

A particularly dangerous commercialization aspect is the proliferation of short-term online courses positioned as full alternatives to university education. These courses, oriented toward rapid practical skills acquisition, often neglect fundamental theoretical foundations and disciplinary historical roots. Students who select such programs obtain fragmented knowledge without understanding deep connections among different scientific fields and their evolution. This leads to superficial thinking formation and incapacity for systematic analysis of complex problems.

The mass proliferation of pseudo-educational programs utilizing attractive marketing and promising rapid results creates an illusion of quality education accessibility with minimal effort. Such programs often exploit people's desire for quick success and social recognition, offering certificates and diplomas

of dubious value. This undermines trust in the genuine educational system and creates unrealistic expectations regarding the educational process.

A critical problem becomes the shift of student audience trust from academic authorities to popular bloggers and social media influencers. Platforms such as TikTok, YouTube, and Instagram become sources of "educational" content often characterized by oversimplification, sensationalism, and absence of scientific rigor [10]. Youth increasingly trust short videos and posts more than systematic instructor lectures, leading to clip thinking formation and incapacity for deep analysis.

The phenomenon of knowledge "Googleization," when information access is confused with education, creates a false notion that years of study can be replaced by several hours of internet searching. This leads to critical thinking skills degradation and inability to distinguish reliable information from manipulative content. Students lose understanding of methodological preparation importance and the scientific approach to cognition.

Commercialization also promotes the spread of instant gratification culture in education, when complex concepts are attempted to be presented as easily digestible "life hacks" and "success secrets." Such substitution of deep learning with superficial tricks forms unrealistic expectations in students and intolerance toward the prolonged intellectual efforts necessary for genuine disciplinary mastery.

### **Globalization and the Challenge of Preserving Cultural Diversity.**

Globalization processes create a paradoxical situation for the contemporary Ukrainian university, which must balance between the necessity of integrating into the international educational space and preserving its own cultural identity. This challenge assumes particular acuity under conditions when unification of educational standards and practices may lead to loss of unique national traditions and approaches to teaching and research activity.

The dominance of English-language educational resources and scholarly publications creates powerful pressure on local teaching languages and scientific discourse. Ukrainian universities face a dilemma: on one hand, Ukrainian language use in the educational process constitutes an important factor in preserving national identity and cultural heritage; on the other hand, the prevalence of English-language content in international scientific sources renders bilingualism or even complete transition to English practically necessary for ensuring graduate competitiveness. [11]

Educational program standardization according to international requirements often presupposes adaptation to dominant Western education models, which may lead to neglect of traditional Ukrainian pedagogical approaches and methodologies. This particularly concerns humanities disciplines, where national specificity of historical experience, literary tradition, and philosophical thought possesses fundamental significance for student cultural identity formation.

International academic mobility, while opening new opportunities for students and faculty, simultaneously creates risks of brain drain and cultural assimilation of the most talented academic community representatives. Graduates who obtain education or work experience at foreign universities often remain in their countries of study, leading to intellectual potential loss and carriers of national cultural tradition.

Global university rankings, which have become an important quality assessment instrument, often employ criteria developed based on Western educational models and values. This compels Ukrainian universities to adapt their activities to foreign standards, which may lead to loss of those unique characteristics that traditionally distinguished Ukrainian higher education.

Educational process digitalization and online platform proliferation, while expanding knowledge access, simultaneously facilitate cultural homogenization. The dominance of large technological corporations in educational technology spheres leads to approach unification in teaching and assessment, which may fail to account for national educational tradition specificity and cultural particularities.

Education commercialization on a global scale leads to educational programs being formed predominantly under the influence of developed country market needs rather than national priorities and

cultural values. This may lead to training specialists who, while competitive in the global labor market, are alienated from their own cultural heritage and national interests.

Research globalization, while facilitating knowledge and innovation exchange, may lead to marginalization of local research topics and traditional knowledge. Ukrainian scholars are compelled to orient toward international trends and funding priorities, which may lead to neglect of research on problems relevant to Ukrainian society and culture. [12]

The influence of global media and social networks on student youth worldview formation creates additional challenges for preserving national cultural identity. The dominance of Western cultural models and values in the global information space may lead to national self-identification crisis among youth.

International university cooperation, while necessary for science and education development, often presupposes asymmetric relationships where Ukrainian universities function more as suppliers of human resources and consumers of ready-made educational products rather than as equal partners in creating new knowledge and educational innovations.

The challenge of preserving cultural diversity under globalization conditions requires Ukrainian universities to develop strategies that would enable integration into the international educational community while preserving their own cultural uniqueness and contribution to global knowledge. This presupposes not passive adaptation to global trends but active participation in forming a multipolar educational space where different cultural traditions complement one another.

An additional factor intensifying the threat of cultural diversity loss is the process of forced higher education institution consolidation caused by declining student numbers and financial difficulties. Demographic crisis and migration processes lead to reduced prospective student contingents, compelling the state and administrative structures to resort to mechanical university mergers as a method of educational system optimization. However, such an approach often ignores the unique history, traditions, and pedagogical schools that developed over decades in individual educational institutions.

The success criterion for consolidated universities increasingly reduces to quantitative indicators such as total student numbers, faculties, and educational programs rather than education quality and academic tradition preservation [13]. Administrative logic guided by the principle that "bigger means better" leads to creation of educational giants where one university may have forty faculties compared to a specialized institution with only five but possessing deep traditions and high-quality specialist training in its fields.

Such mechanical consolidation often destroys unique pedagogical schools and scientific directions that formed over many years. Specialized universities that had reputations as centers of advanced knowledge in specific fields lose their identity within large multidisciplinary entities. This leads to academic excellence dilution and loss of those competitive advantages that made these educational organizations unique.

The consolidation process often accompanies educational program standardization and administrative procedure unification, which may lead to loss of innovative pedagogical approaches and methodologies developed in individual educational institutions. Many years of experience working with specific knowledge fields and specific professional community needs risk being lost in the formal integration process.

The educational institution culture and atmosphere formed over years through faculty, student, and alumni interaction proves particularly vulnerable to consolidation processes. Scientific school traditions, student initiatives, informal connections between scholar generations—all this may be lost as a result of mechanical merger of different organizational cultures.

### **Problems of Education Quality Assessment and Accountability.**

The contemporary education quality assessment system in Ukrainian universities is characterized by profound contradictions between formal indicators and real educational achievements. This problem assumes particular acuity in the context of growing accountability requirements for universities before

the state, society, and international partners, when quantitative metrics often substitute for qualitative characteristics of the educational process.

The dominance of bureaucratic approaches to education quality assessment leads to creation of complex reporting systems that absorb significant university resources but do not always adequately reflect the actual state of affairs. Faculty and administrators are forced to spend increasingly more time preparing reports, completing forms, and participating in formal assessment procedures instead of concentrating on direct educational and research activity.

Mechanical application of international assessment standards to Ukrainian universities often fails to account for national educational system specificity, historical traditions, and cultural context. Criteria developed for Western universities may be inadequate for evaluating Ukrainian higher education institutions, leading to distorted perceptions of their real achievements and potential. [14]

The problem also lies in excessive attention to easily measurable indicators such as publication numbers, citation indices, and rankings at the expense of more difficult-to-assess aspects of university activity. Teaching quality, impact on student personality formation, contribution to local community development, and cultural tradition preservation are difficult to quantify, yet they often determine the true value of university education.

The university ranking system, which has gained widespread adoption, creates false incentives for educational institution development. The desire to improve ranking positions may lead to effort concentration on indicators that directly affect ranking positions at the expense of activity aspects important to students and society but not reflected in rankings.

Imperfect feedback mechanisms from students and employers complicate objective educational process quality assessment. Traditional surveys often fail to provide sufficiently deep understanding of student educational experience, and employer opinions about graduate preparation quality are rarely systematically considered in university evaluation.

The accountability problem is also complicated by the multiplicity of stakeholders to whom universities must report. Government bodies, students, parents, employers, international partners, and the public often have different and sometimes contradictory expectations regarding university activities. This leads to the necessity of balancing different requirements and may result in losing focus on the university's core mission.

Insufficient funding for quality assessment procedures leads to their formalization and reduced effectiveness. External experts often lack sufficient time and resources for deep analysis of university activities, leading to superficial conclusions and recommendations.

Assessment culture in Ukrainian universities is often characterized by fear of negative consequences from honest self-analysis [15]. This leads to problem concealment and indicator inflation instead of open discussion of challenges and searching for solutions. Such an atmosphere impedes real education quality improvement.

The absence of long-term perspective in assessment systems leads to concentration on short-term results at the expense of strategic development. Universities are compelled to demonstrate rapid indicator improvements, which may lead to decisions that are counterproductive in the long term.

Technological limitations and insufficient digital infrastructure complicate implementation of modern education quality assessment methods. The absence of data analytics systems and automated monitoring instruments renders assessment processes labor-intensive and less precise.

The qualification problem of experts involved in education quality assessment also requires attention. Insufficient assessor preparation, their unfamiliarity with specific knowledge field specifics or contemporary education trends may lead to inadequate conclusions and recommendations that do not contribute to real educational process quality enhancement.

Particularly acute is the problem of excessive administrative burden on faculty, who are forced to spend a significant portion of working time completing numerous reports, tables, and forms instead of class preparation and research work. Faculty are transformed into clerks who devote more time to paperwork than direct communication with students and educational program development. This leads

to a paradoxical situation where efforts directed at education quality control actually reduce this quality by diverting faculty from their core functions.

The bureaucratic apparatus demands from faculty detailed documentation of every activity aspect: from lesson plans to reports on individual student learning plan fulfilment [15]. Such a level of detail is often excessive and fails to reflect real educational process quality, but absorbs resources that could be directed toward teaching methodology improvement and innovative educational approach development.

The Ministry of Education, pursuing the goal of higher education restructuring and modernization, often loses sight of the main objective—ensuring high-quality specialist training. Instead of assessing the real level of student knowledge and competencies, attention focuses on formal university activity indicators: numbers of defended dissertations, volumes of scholarly publications, material and technical base size, and faculty numbers.

Such goal substitution leads to distorted understanding of university education effectiveness, when an institution with powerful infrastructure and large faculty numbers may be considered successful even with low graduate preparation quality. Simultaneously, small specialized universities ensuring high professional training levels may receive negative assessments due to modest material base indicators.

The pursuit of quantitative indicators prompts universities toward artificial statistical data inflation and reporting manipulation. This creates an illusion of education quality improvement while real problems remain unresolved. Energy and resources that should be directed toward faculty qualification enhancement, educational program renewal, and learning condition improvement are expended on report preparation and formal indicator maintenance.

### **The Necessity of Innovative Teaching Methods.**

The contemporary Ukrainian university urgently requires fundamental transformation of pedagogical approaches, as traditional teaching methods increasingly fail to correspond to the needs of the digital generation and demands of a dynamically changing labor market. The crisis of the traditional lecture-seminar system manifests in declining student motivation, their passivity during classes, and inability to apply acquired knowledge in practical situations.

The dominance of frontal teaching methods, when the instructor serves as the sole information source and students passively receive it, contradicts contemporary conceptions of effective learning. Such an approach does not facilitate critical thinking development, creativity, and independent problem-solving skills, which constitute key twenty-first century competencies. Students become accustomed to the role of ready-made information consumers instead of learning to independently analyze, synthesize, and create new knowledge.

The absence of interactive learning methods results in students not obtaining sufficient experience in teamwork, public speaking, discussions, and argumentation of their own positions. These skills are critically important for successful professional activity in the modern world, where capacity for effective communication and collaboration often determines career success more than purely academic knowledge. [16]

Insufficient technology use in the learning process renders Ukrainian universities uncompetitive compared to foreign educational institutions. Virtual reality, artificial intelligence, adaptive learning systems, and other contemporary technologies could significantly enhance learning effectiveness, but their implementation is constrained by both financial limitations and faculty conservatism.

The problem also lies in many instructors not possessing contemporary pedagogical methodologies and digital competencies necessary for implementing innovative learning approaches. The absence of systematic faculty professional development programs in pedagogical innovations leads to preservation of outdated teaching methods even in cases where modernization opportunities exist.

Curriculum and program rigidity impedes implementation of flexible learning methods such as project-based learning, flipped classroom, or integrated interdisciplinary courses. Bureaucratic procedures for approving curriculum changes render the innovation process excessively slow and complex, demotivating instructors from experimenting with new approaches.

Underestimation of education's practical component importance leads to a disconnect between theoretical knowledge and real labor market needs. Students often complete university with substantial theoretical knowledge baggage but without practical application skills. The absence of close employer collaboration and limited internship opportunities complicate integration of the practical component into the educational process.

The traditional assessment system, based predominantly on memorization and information reproduction, does not stimulate creative thinking development and innovative approaches to problem-solving. Students orient toward formal task completion and grade attainment instead of deep material understanding and professional competency formation.

The absence of personalized learning approaches ignores individual student characteristics, abilities, and needs. Unified curricula and teaching methods fail to account for learning style diversity and material absorption pace variation, leading to ineffective utilization of each student's potential.

Insufficient attention to soft skills and emotional intelligence development leaves graduates unprepared for contemporary work environment challenges. Adaptability, leadership, conflict management, and stress resilience capacities become increasingly important, but traditional teaching methods rarely facilitate their formation.

The absence of experimentation and innovation culture in pedagogical practice constrains university education development. Instructors often lack incentives for seeking new working methods, and administration does not always support educational process modernization initiatives. This leads to stagnation and gradual falling behind global educational trends.

Simultaneously, it is important to emphasize that educational innovations must not lead to complete departure from fundamental principles of scientific cognition and understanding of knowledge historical roots. Despite educational process digitalization necessity, students must understand scientific discipline origins, scientific thought evolution, and methodological foundations of cognition. Superficial fascination with newest technologies may lead to loss of connection with fundamental principles upon which scientific knowledge is based [17].

### **Insufficient Adaptation of Maritime Universities to Contemporary Challenges.**

Ukrainian maritime higher education providers find themselves in a particularly difficult situation, as the specificity of their activities renders them extraordinarily vulnerable to all the above-described challenges of contemporary university education. The conservative nature of maritime education, which historically was based on strict traditions and time-tested practices, proves inadequate under conditions of rapid technological changes and maritime industry globalization.

Financial difficulties of maritime universities are intensified by specific expenditures on maintaining training vessels, specialized equipment, and simulator complexes. High costs for student maritime practice, the necessity of regular navigation equipment and safety system renewal create additional burden on these institutions' budgets. Simultaneously, decreased state support for the maritime sector leads to critical underfunding that threatens the very existence of quality maritime education in Ukraine.

Psychological problems of maritime specialty students are complicated by future profession specificity, which presupposes prolonged isolation, absence of constant family contact, and high stress levels [18]. The military situation in the Black and Azov Seas creates additional risks and uncertainty regarding practical training opportunities and graduate employment prospects.

Quality assessment systems in maritime universities often fail to account for maritime training specificity, focusing on general academic indicators instead of professional competencies necessary for work at sea. International standards for maritime specialist training require special assessment approaches that do not always align with national education quality control systems.

Implementation of innovative teaching methods in maritime universities encounters additional obstacles due to the necessity of preserving the practical learning component. Virtual technologies, while capable of complementing traditional training, cannot completely replace real shipboard work

experience. This creates a challenge in seeking optimal balance between innovative methods and irreplaceable practical skills.

The overall picture indicates that Ukrainian universities find themselves in a survival situation where all resources are directed toward maintaining basic functioning instead of development and modernization. This creates long-term risks for higher education quality and Ukrainian educational system competitiveness at the international level.

The complexity of maritime university adaptation is also intensified by the geopolitical situation, which limits opportunities for international cooperation with certain countries and complicates access to contemporary maritime technologies and equipment. This renders the maritime education modernization process even more complex and expensive.

**The Purpose and Tasks of the Study.** Practical experience demonstrates that the systemic representation of education as an approach to organizing and understanding the educational process includes not only students and instructors but also diverse educational resources, methods and technologies, as well as the social, economic, and political environment in which learning occurs. This approach considers the interaction of all system components and aims to achieve the most effective fulfillment of educational objectives. Two paradigms, two approaches have formed in the education sphere: traditional and competency-based. The competency-based approach is gaining popularity in education as it emphasizes the development of practical skills and abilities directly applicable in the workplace.

The study aims to identify contemporary challenges and developmental trends in universities considering sectoral educational institution specificity in the context of systemic representation of the educational process [19]. A competent contemporary specialist differs from a qualified one in the capacity to realize knowledge, skills, and abilities in professional activity. This approach represents a departure from traditional education methods that prioritize memorization over practical application and learning outcomes.

The contemporary economy is increasingly becoming digital, and consequently more young people are choosing technical specializations. Demand for IT specialists remains high, but as digital knowledge spreads, IT expertise will shift from a specialty to basic literacy skills. Interdisciplinary education becomes more important as technology intersects with various fields. However, technical skills are insufficient for digital economy development. Soft skills, communication abilities, capacity to work in teams, and adaptability to others are extraordinarily important. Unfortunately, traditional educational systems do not devote sufficient attention to these skills.

Special attention in the research is devoted to the problem of declining maritime university student numbers as an example of sectoral specificity. Any professional's success largely depends on faculty mastery and qualification. Education is not only what occurs in the classroom; it also encompasses the broader aspect of interaction between students and lecturers, curricula, and even examinations. The instructor's role is changing from specialist-demonstrator to organizer-educator. Simultaneously, increasing attention is devoted to student self-education and self-learning. Practical activities for students serve as the most adequate means of transforming acquired knowledge into practical skills.

Particularly alarming is the trend toward replacing traditional information sources with digital platforms without forming critical media literacy in students. Google, Wikipedia, and other online resources should serve as tools assisting the educational process rather than replacing libraries, archives, and systematic information searching. The illusion that all necessary information is accessible through search engines is dangerous, as a significant portion of scholarly knowledge, especially historical sources, specialized research, and unique materials, are not digitized and require traditional search methods.

A generation of students is forming who believe that if Google does not find certain information, it does not exist at all. Such simplified understanding of knowledge accessibility leads to research horizon narrowing and loss of primary source working skills. Students lose the ability to work with catalogs, archival materials, printed publications, and other traditional information carriers, which limits their research capabilities.

Digital technologies should complement rather than replace fundamental academic work skills [20]. The ability to analyze primary sources, conduct systematic bibliographic searches, work with archival materials, and critically assess information reliability remain irreplaceable competencies for genuine scholars. Loss of these skills leads to research superficiality and scientific work quality decline.

Educational innovations should aim at synthesizing traditional and contemporary methods rather than complete replacement of the former by the latter. Effective future education must combine digital technology advantages with deep understanding of science's methodological foundations, historical perspective of knowledge development, and skills for working with diverse information source types.

To illustrate the mentioned problems, analysis of student admission capacity to maritime universities was conducted for the period 2020-2024 (Fig. 1). The study examined admission activity and student contingents at four leading maritime institutions: the National University "Odessa Maritime Academy" (NUOMA), Odessa National Maritime University (ONMU), Kherson State Maritime Academy (KSMA), and National Transport University (NTU). Statistical data demonstrate an alarming trend: if in 2020 the number of prospective students constituted approximately 21,000 persons, already in 2021 this indicator decreased to 19,500, in 2022 to 19,200. A slight increase in 2023 to 20,600 persons did not compensate for the overall negative trend, and in 2024 a sharp drop to 18,000 prospective students was observed. This dynamic reflects not only demographic crisis but also declining attractiveness of maritime specializations among youth, necessitating further detailed analysis of student contingents at individual maritime educational facilities for the analogous period.

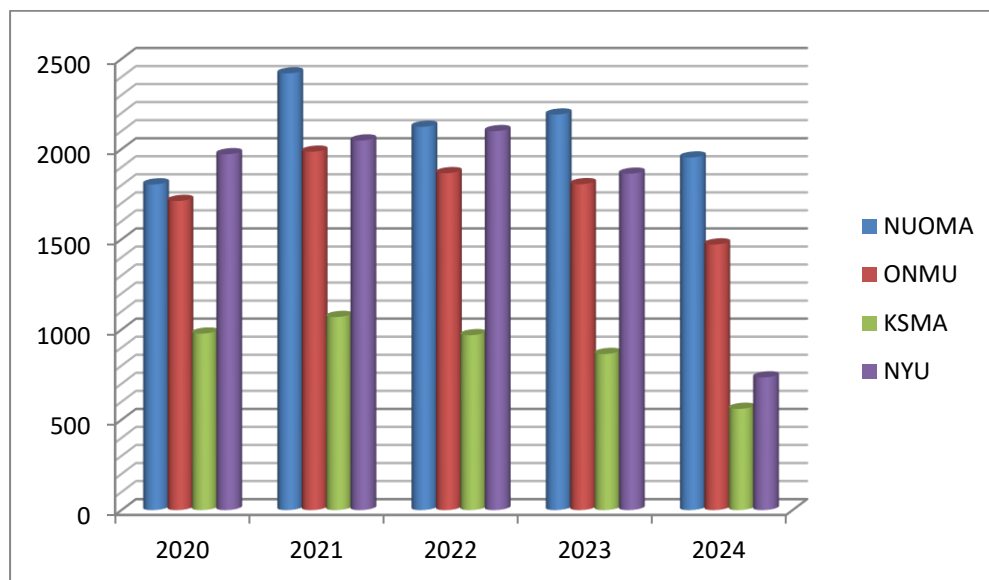

**Fig. 1. Dynamics of prospective student numbers in Ukrainian maritime higher education (2020–2024)**

Contemporary demographic trends in Ukraine demonstrate alarming signs of intellectual and physically developed young population outflow to other countries. This process, alongside a complex of socioeconomic problems, indicates a profound demographic crisis threatening state national security. The ongoing war leads to mass emigration of families with children seeking safety and stability abroad. Particularly critical is the situation when children who completed secondary school in temporary residence countries more frequently choose foreign universities for continuing education rather than returning to Ukraine for study.

Educational process organization in Ukrainian higher education faces numerous challenges. Completion of the 2021/2022 academic year occurred under difficult conditions, and although the educational process was successfully ensured, this required enormous effort. The academic year concluded in accelerated mode, especially for universities that were relocated or damaged, causing

additional burden on students, faculty, and administration. Motivation to teach and learn was significantly affected by the constant state of uncertainty, unstable psychoemotional background, and frequent air raid signals, and in some cases shelling, encountered by educational process participants.

The situation in Ukraine's maritime education system causes particular concern. Analysis of student contingents in four leading maritime higher education for the period 2020-2024 demonstrates critical reduction. Maritime education constitutes a strategically important sector in Ukraine's higher education system, as it forms personnel potential for one of the key national economy sectors. Maritime higher education ensure training of highly qualified specialists across a broad spectrum of specializations: deep-sea captains, ship engineers, radio electronics specialists, port operators, logistics specialists, and maritime transport management professionals. These specialists form the foundation of functioning not only merchant shipping but also fisheries, maritime construction, coast guard, and naval forces.

Ukrainian maritime training centers possess international recognition and accreditation according to International Maritime Organization (IMO) requirements and the International Convention on Standards of Training, Certification and Watchkeeping for Seafarers (STCW). This enables Ukrainian seafarers to work on vessels under various world state flags, rendering maritime education an export-oriented sector and source of foreign currency inflows to the country.

Analysis of Ukrainian maritime university student contingents demonstrates heterogeneous dynamics throughout 2020-2024. The National University "Odessa Maritime Academy" (NUOMA) maintains leading positions by student numbers, although gradual contingent decline is observed from 7,900 persons in 2020 to 6,700 in 2024, constituting a 15.2% reduction.

Odessa National Maritime University (ONMU) demonstrates more stable indicators with minor fluctuations. After declining from 5,500 students in 2020 to 5,000 in 2022, recovery to 5,800 persons in 2023 is observed with subsequent decrease to 5,200 in 2024. Overall contingent reduction constituted 5.5%.

Kherson State Maritime Academy (KSMA) is characterized by the smallest student numbers among studied institutions. Contingent fluctuates within the range of 2,400-3,700 persons with a declining tendency in recent years. A particularly noticeable drop occurred in 2024 to 2,400 students, related to military operations in the regional territory.

National Transport University (NTU) shows the greatest indicator volatility. After declining from 4,300 students in 2020 to 3,700 in 2021, growth to 5,000 persons in 2023 was observed with subsequent reduction to 4,100 in 2024.

Overall trends indicate reduction of aggregate maritime university contingent from 21,100 students in 2020 to 18,400 in 2024, constituting a 12.8% decrease (Fig. 2). The most critical period falls on 2022-2024, correlating with full-scale war commencement and its consequences for Ukraine's higher education system. Structural changes in student distribution among educational establishments remain relatively stable; however, all universities experience negative impact of external factors on contingent formation.

This dynamic reflects not only demographic crisis but also declining attractiveness of maritime specializations among youth, geopolitical risks associated with military operations, and general destabilization of the higher education system under war conditions.

Aggregate analysis of total student numbers across the maritime education sector for the studied period confirms the situation's critical nature. The initial contingent of 21,000 students in 2020 demonstrated stable sectoral potential. However, already in 2021 the first significant reduction to 19,500 persons is observed, constituting a 7.1% decrease (Fig. 3). This decline can be explained both as consequences of the COVID-19 pandemic and initial manifestations of demographic crisis.

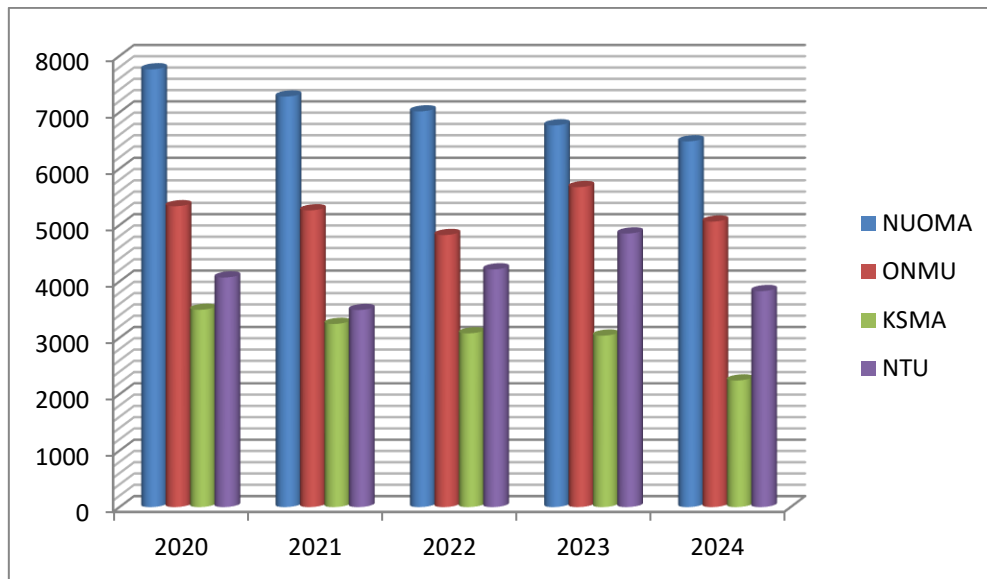

**Fig. 2. Dynamics of the student contingent in Ukrainian maritime higher education (2020–2024)**

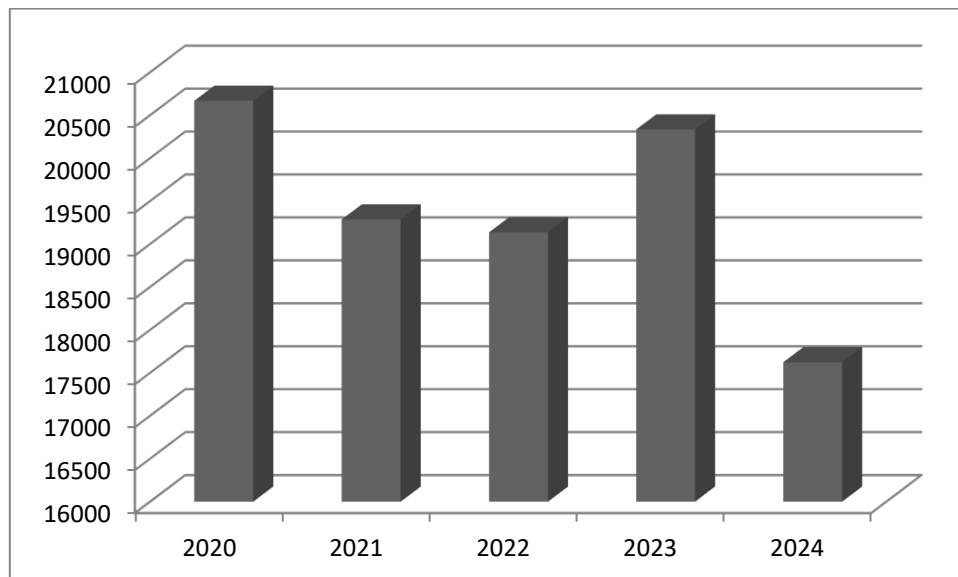

**Fig. 3. Dynamics of the total number of students in Ukrainian maritime education (2020–2024)**

In 2022, student numbers decreased to 19,200, which is not the lowest level for the studied period, unlike 2024 when a sharp drop to 18,000 persons occurred—the lowest indicator. The most critical decline in 2024 is associated with consequences of full-scale war, infrastructure destruction, mobilization, and population migration.

In 2023, some contingent recovery occurred to 20,500 students, likely indicating educational system adaptation to wartime conditions, including distance learning. However, this growth proved temporary and did not compensate for the overall negative trend.

Comprehensive analysis of possible causes for such negative dynamics allows identification of several key factors. Among the most influential should be noted structural changes in Ukraine's population age pyramid caused by prolonged depopulation and mass emigration, leading to critical reduction in prospective student numbers in the 17-22 age category. Second, families' economic difficulties reduce education financing possibilities, especially under martial law conditions when survival becomes the priority.

A significant factor is the geopolitical situation change in the Black Sea region. Crimea's annexation in 2014 and loss of control over part of the Black Sea water area reduced maritime profession attractiveness due to Ukrainian seafarer employment limitations. Ukrainian port blockade during the war additionally emphasized the maritime sector's riskiness as a professional activity sphere.

Psychological factors also play an important role. Youth increasingly choose the IT sphere, medicine, or other fields considered more promising and safer. Maritime professions, traditionally associated with distant voyage romance, are now perceived through the prism of military risks and economic instability.

Maritime educational institution infrastructure problems, including material and technical base damage, partial faculty transfer to military service, and general education funding reduction, create additional obstacles for quality specialist training.

Overall contingent reduction of 14.3% over four years creates a threat to Ukraine's strategic security in the maritime sphere. Such decline rates may lead to qualified personnel deficits in critically important national economy sectors, which is particularly dangerous under conditions of necessary post-war maritime infrastructure reconstruction.

The research was conducted based on a comprehensive methodological foundation combining systemic and comparative analysis for thorough examination of Ukrainian maritime education state in the context of contemporary educational challenges. The systemic approach enabled consideration of maritime education as an integral system functioning under conditions of internal and external factor interaction, including demographic trends, economic conditions, geopolitical situation, and technological innovations.

**Materials and Methods of Research.** Systemic analysis was applied to research the structure and functioning of maritime higher education as components of the overall personnel training system for the national economy. This method enabled identification of interrelationships among different educational process components and their influence on student contingent formation. Comparative analysis was employed to juxtapose individual maritime educational institution development dynamics, identify common trends and specific characteristics of each studied university. This approach ensured the possibility of identifying the most critical problems and successful practices for adapting to changing conditions.

Content analysis of publications was conducted to systematize scholarly perspectives on contemporary higher education problems, including analysis of materials from international educational organizations, domestic and foreign researchers regarding university education transformation under digitalization and global challenge conditions. Statistical data analysis provided quantitative assessment of maritime education trends, including percentage change calculation, trend determination, and forecasting of possible sectoral development scenarios.

The conducted analysis of scholarly literature and practical experience of higher education institution functioning enabled systematization of main challenges confronting contemporary university education in Ukraine. For the purpose of structuring identified problems and outlining possible resolution pathways, a summary table was compiled reflecting key educational system dysfunctions and potential mechanisms for overcoming them (Table 1).

The problems presented in Table 1 demonstrate the systemic nature of crisis phenomena in Ukraine's higher education sphere, which have assumed particular acuity under conditions of full-scale Russian aggression. Particularly alarming is the trend toward overall student contingent reduction, indicating not only demographic challenges but also structural deformations in the personnel training system for the national economy. This phenomenon assumes critical significance in the context of future country reconstruction needs when demand for qualified specialists will significantly increase.

These trends manifest most clearly in the maritime education sphere, where student contingent reduction may have long-term negative consequences for maritime sector development and Ukraine's economy overall. Analysis of student number dynamics in leading maritime higher education for the period 2020-2024 enables specification of these processes' scale and identification of specific features of maritime university adaptation to contemporary challenges.

**Table 1. Main Problems of Contemporary University Education and Their Possible Solutions**

<b>Problem</b>	<b>Description</b>	<b>Possible Solution</b>
Financial crisis	Chronic university underfunding, less than 1% of GDP, limited financing diversification opportunities	Searching for new financing models, public-private partnerships, endowment funds
Wartime education challenges	Student evacuation, distance learning during air raids, infrastructure destruction	Creation of mobile educational centers, development of resilient distance learning systems
Energy problems	Electricity outages affecting the educational process	Installation of autonomous energy sources, development of offline resources
Obsolete material and technical base and digital divide	Absence of modern equipment, laboratories, digital resources and technologies for online learning	Comprehensive modernization: equipment renewal + digital infrastructure development
Personnel crisis	Low salaries, mass scholar emigration, absence of prospects	Salary increases, emigrant return programs, creation of career growth conditions
Demographic crisis	Prospective student number reduction due to low birth rates and emigration	Attracting foreign students, lifelong learning programs, personnel retraining
Limited international cooperation	Absence of funding for participation in international projects, conferences	Attracting international grants, developing online partnerships with foreign universities
Research activity reduction	Insufficient funding for fundamental and applied research	Creating university-business consortia, crowdfunding scientific projects
Student mental health deterioration	War impact, stress, isolation, digital fatigue, traumatic experience	Expansion of psychological support services, mental health support programs, mutual aid groups
Outdated curricula	Misalignment with contemporary labor market demands and global standards	Continuous market needs monitoring, employer engagement in program development
Insufficient attention to soft skills	Absence of soft skills development, critical thinking, communication	Integration of soft skills development into all disciplines, project-based learning
Education commercialization	Profit priority over education quality, lowering of academic standards	Development of education quality standards, independent monitoring, accreditation
Language challenges in education	Necessity of balance between Ukrainian language and English-language resources	Development of quality Ukrainian-language resources, bilingual learning programs
Imperfect quality assessment system	Bureaucratization, orientation toward formal indicators instead of real quality	Implementation of comprehensive assessment system with student and employer participation
Absence of innovative teaching methods	Dominance of traditional lecture-seminar system, low interactivity	Faculty professional development, implementation of active learning methods

Problem	Description	Possible Solution
Special challenges of maritime universities	High costs for specialized equipment, maritime practice limitations due to port blockade	Specialized state support programs, international internships, simulation technologies

The empirical research base consisted of official statistical data from four leading Ukrainian maritime higher education for the period 2020-2024: the National University "Odessa Maritime Academy," Odessa National Maritime University, Kherson State Maritime Academy, and National Transport University. Data included annual student contingent numbers, admission structure by specializations, and regional prospective student distribution.

**Conclusions.** The conducted research confirms that Ukraine's contemporary higher education system is experiencing a profound structural crisis that manifests particularly acutely in sectoral educational institutions, specifically maritime universities. Analysis of maritime higher education institution student contingent dynamics for the period 2020-2024 revealed critical reduction of 14.3%, reflecting not only demographic challenges but also systemic problems of educational system adaptation to contemporary realities.

The research confirmed that the maritime education crisis has multifactorial character and is caused by interaction of demographic, economic, geopolitical, and psychological factors. Structural changes in the population age pyramid caused by prolonged depopulation and mass emigration led to critical reduction in prospective student numbers. Families' economic difficulties under martial law conditions limit education financing possibilities, while the geopolitical situation in the Black Sea region reduces maritime profession attractiveness due to risks and employment limitations.

Particularly alarming is the trend of youth educational priority shifting toward the IT sphere and other fields considered more promising and safer. Maritime professions, traditionally associated with distant voyage romance and stable earnings, are now perceived through the prism of military risks and economic instability.

Analysis results indicate the necessity of fundamental rethinking of approaches to maritime education development in Ukraine. Mechanical educational institution consolidation, considered as a system optimization method, risks leading to loss of unique pedagogical traditions and specialized competencies formed over decades. The success criterion based on quantitative indicators fails to reflect real education quality and may lead to academic excellence destruction.

The research revealed the critical problem of excessive administrative burden on faculty, when energy and time that should be directed toward direct educational activity are expended on bureaucratic procedures. Such a situation not only reduces educational process quality but also demotivates talented instructors, intensifying the sectoral personnel crisis.

A particularly important conclusion is the necessity of a balanced approach to educational innovation implementation. Despite the importance of digitalization and educational process modernization, it is critically important to preserve fundamental principles of scientific cognition and knowledge historical roots. Superficial fascination with newest technologies without understanding science's methodological foundations may lead to formation of a specialist generation with fragmentary knowledge and limited research capabilities.

Research results emphasize the strategic importance of maritime education for national security and Ukraine's economic development. Overall contingent reduction of 14.3% over four years creates a real threat of qualified personnel deficits in critically important national economy sectors, which is particularly dangerous under conditions of necessary post-war maritime infrastructure reconstruction.

To overcome identified problems, development of a comprehensive maritime education development strategy is necessary, which should include: enhancing maritime profession prestige through information campaigns and career prospect demonstration; creating effective cooperation mechanisms with international maritime companies to ensure graduate employment guarantees; modernizing maritime university material and technical bases according to contemporary international standards;

developing innovative educational programs combining traditional maritime knowledge with modern technologies.

Prospects for further research lie in detailed analysis of international experience in overcoming crisis phenomena in maritime education, studying possibilities for adapting successful foreign practices to Ukrainian realities, and developing concrete mechanisms for enhancing maritime specialist training system effectiveness under resource-constrained conditions and geopolitical challenges.

## REFERENCES

1. Yarzhevska, V. (2023). Peculiarities of media activity in the Khmelnytsky region during the war between Russia and Ukraine. *Ukrainian Information Space*, 2(12), 135–148. [in Ukrainian]. [https://doi.org/10.31866/2616-7948.2\(12\).2023.291174](https://doi.org/10.31866/2616-7948.2(12).2023.291174).
2. Zhytariuk, M. (2023). Evaluation and rethinking of the work of journalists in the conditions of the war for independence of Ukraine. *Ukrainian Information Space*, 1(11), 55–71. [in Ukrainian]. [https://doi.org/10.31866/2616-7948.1\(11\).2023.279558](https://doi.org/10.31866/2616-7948.1(11).2023.279558).
3. Puyda, R., & Dvorianyn, P. (2024). Higher education reform in Ukraine (2014–2022) in the reception of domestic social media. *East European Historical Bulletin*, (31), 203–217. <https://doi.org/10.24919/2519-058X.31.306356>.
4. Utami, A. Y., Wahyuni, A., & Azaria, L. (2023). Exploring the Dynamics of University Systems: Navigating Structures, Challenges, and Innovations in Higher Education. *Journal of Education Review Provision*, 3(3), 136–142. <https://doi.org/10.55885/jerp.v3i3.318>.
5. Purba, C. A., Tao, L., & Al-Hosaini, F. F. (2024). Impact of Educated Managers on Enhancing School Performance. *Journal of Organizational Behavior Management*, ISSN, 1540-8604. <http://dx.doi.org/10.2139/ssrn.4856989>.
6. Abubakar, A. A., Al-Mamary, Y. H., Singh, H. P., Singh, A., Alam, F., & Agrawal, V. (2024). Exploring factors influencing sustainable human capital development: Insights from Saudi Arabia. *Heliyon*, 10(16), e35676. <https://doi.org/10.1016/j.heliyon.2024.e35676>.
7. Makuachukwu, S. (2023). A Study on the Effects of Professional Development on Teacher Leadership Skills. *Journal of Asian Multicultural Research for Educational Study*, 4(2), 24–31. <https://doi.org/10.47616/jamres.v4i2.405>.
8. Memon, S., Bhutto, A., & Chowdhry, B. S. (2025). “We Also Matter”: Investigating Organizational Support and Recognition Mechanisms for Non-Academic Staff in Public Universities. *Quantic Journal of Social Sciences and Humanities*, 6(1), 380–392. <https://doi.org/10.55737/qjssh.vi-i.25341>.
9. Kinto-Ramírez, H., Yunes-Rojas, J. A., Nieto-Jalil, J. M., Morales-Nava, R., Sayeg-Sánchez, G., & Lozano-Aponte, J. (2025, July). Integrating Narrative Learning and AI for Collaborative Problem Solving in Engineering Education. In *2025 6th International Conference of the Portuguese Society for Engineering Education (CISPEE)* (pp. 1–7). IEEE. <https://doi.org/10.1109/CISPEE64787.2025.11124044>.
10. Wahyudin, W., Riza, L. S., Erlangga, E., & Al Husaeni, D. N. (2025). Machine learning-based clustering for program learning outcomes in higher education: A systematic review. *Brilliance: Research of Artificial Intelligence*, 5(1), 182–189. <https://doi.org/10.47709/brilliance.v5i1.5953>.
11. Syoviana, E., Giantara, H., Ramadhan, F., Month, T. L., Syai'un, A., Fajrina, H. P., Fitri, H., Arianti, N., Sarifah, A., Ardina, N., Abdullah, A. R., Saputra, R., & Gunawan, G. (2025). Professional competence of teachers in improving the quality of learning. *Indonesian Research Journal in Education (IRJE)*, 9(02), 1043–1054. <https://doi.org/10.22437/irje.v9i02.46712>.
12. Khan, S. A., & Iqbal, Z. (2025). Exploring the effectiveness of teachers working in non-formal basic education schools in the Punjab. *Research Journal for Social Affairs*, 3(4). <https://doi.org/10.71317/RJSA.003.04.0256>.
13. Sichko, T., Zelinska, O., & Afanasieva, D. (2025). Higher education in the age of Artificial Intelligence: Opportunities and challenges. *Herald of Khmelnytskyi National University. Technical Sciences*, 347(1), 314–319. <https://doi.org/10.31891/2307-5732-2025-347-41>.
14. Oleshko, A., & Lebediev, M. (2025). Higher education in the context of the knowledge economy, digital economy, and sustainable development. *European Scientific Journal of Economic and Financial Innovations*, 1(15), 331–339. [in Ukrainian]. <https://doi.org/10.32750/2025-0129>.
15. Bataieva, K. (2025). Higher education in a frontline city during the Russian-Ukrainian war: Cumulative effects of prolonged online learning. *Sociology: Theory, Methods, Marketing. Institute of Sociology NASU*, (2), 116. <https://doi.org/10.15407/sociology2025.02.116>.
16. Holmes, W., & Tuomi, I. (2022). State of the art and practice in AI in education. *European journal of education*, 57(4), 542–570. <https://doi.org/10.1111/ejed.12533>.
17. Wang, T., Lund, B. D., Marengo, A., Pagano, A., Mannuru, N. R., Teel, Z. A., & Pange, J. (2023). Exploring the potential impact of artificial intelligence (AI) on international students in higher education: Generative AI, chatbots, analytics, and international student success. *Applied Sciences*, 13(11), 6716. <https://doi.org/10.3390/app13116716>.
18. Chichekian, T., & Benteux, B. (2022). The potential of learning with (and not from) artificial intelligence in education. *Frontiers in Artificial Intelligence*, 5, 903051. <https://doi.org/10.3389/frai.2022.903051>.
20. Latyk, N., Sakovets, N., & Sanayko, A. (2024). Higher education in Ukraine under war conditions. *Humanities Studies: Pedagogy*, 19(51), 51–58. [in Ukrainian]. <https://doi.org/10.24919/2413-2039.19/51.6>.

20. Nechytailo, O., & Kolotylo, O. (2021). Changes in the modern university: Challenges and development trends. *Bukovinian Medical Herald*, 25(4(100)), 133–137. [in Ukrainian]. <https://doi.org/10.24061/2413-0737.XXV.4.100.2021.22>.

**Ольга Петриченко<sup>1</sup>, Ігор Бурмака<sup>2</sup>, Алла Виноградова<sup>3</sup>, Тимур Столярник<sup>4</sup>**

<sup>1</sup>Доктор філософії, завідувач кафедри управління судном, Національний університет «Одеська морська академія», вул. Дідріхсона, 8, м. Одеса, 65052, Україна. ORCID: <https://orcid.org/0009-0003-1294-2740>.

<sup>2</sup>Доктор технічних наук, професор, директор Інституту навігації, Національний університет «Одеська морська академія», вул. Дідріхсона, 8, м. Одеса, 65052, Україна. ORCID: <https://orcid.org/0009-0005-9069-7378>.

<sup>3</sup>Провідний фахівець Інституту навігації, Національний університет «Одеська морська академія», вул. Дідріхсона, 8, м. Одеса, 65052, Україна. ORCID: <https://orcid.org/0009-0006-3274-716X>.

<sup>4</sup>Доктор філософії, Національний університет «Одеська морська академія», вул. Дідріхсона, 8, м. Одеса, 65052, Україна. ORCID: <https://orcid.org/0000-0002-2922-9728>.

### **Структурна криза сучасної вищої освіти: системний підхід до інституційної стійкості та трансформації**

**Анотація.** Це дослідження має на меті визначити сучасні проблеми та тенденції розвитку університетської освіти, з акцентом на галузевих навчальних закладах через системний підхід до аналізу освітнього процесу. Методологічна основа поєднує системний та порівняльний аналіз для комплексного вивчення морської вищої освіти як невід'ємного компонента загальної системи підготовки кадрів. Було проведено контент-аналіз наукових публікацій разом зі статистичним аналізом офіційних даних чотирьох провідних морських університетів України за 2020-2024 роки, включаючи динаміку набору та структуру прийому за спеціалізаціями. Наукова новизна полягає у всебічному аналізі конкретних викликів, що стоять перед морською освітою, включаючи унікальні проблеми, такі як обмеження морської практики через блокаду портів, необхідність адаптації до міжнародних стандартів в умовах обмежених ресурсів та зміна сприйняття морських професій в умовах ризиків воєнного часу. Практичне значення полягає в розробці конкретних рекомендацій щодо подолання кризових явищ, включаючи створення стійких систем дистанційного навчання, розвиток міжнародних партнерств та впровадження інноваційних підходів до навчання в умовах обмежених можливостей. Висновки дослідження підкреслюють стратегічну важливість морської освіти для національної безпеки та необхідність розробки комплексної стратегії розвитку.

**Ключові слова:** проблеми освіти, освітні програми, цифрова трансформація, психічне здоров'я студентів, оцінювання якості, морські університети, зниження рівня вступу.

*Дата першого надходження статті до видання 15.10.2025*

*Дата прийняття до друку статті 21.11.2025*

UDC 656.183

**Oleksandra Orda<sup>1\*</sup>, Yehor Holubnichii<sup>2</sup>**

<sup>1</sup>Associate professor, Department Transport Technologies, Kharkiv National Automobile and Highway University, St. Yaroslava Mudroho 25, Kharkiv, 61002, Ukraine ORCID: <https://orcid.org/0000-0002-7213-8469>.

<sup>2</sup>Master student, Kharkiv National Automobile and Highway University, 25, Yaroslava Mudroho St., Kharkiv, 61002, Ukraine ORCID: <https://orcid.org/0009-0004-0216-3687>.

\*Corresponding author: [kostalexandra@gmail.com](mailto:kostalexandra@gmail.com).

### **Planning of bicycle infrastructure for urban sustainable mobility: Kharkiv case study**

*The paper presents a comprehensive approach to strategic planning of bicycle infrastructure as a key element of sustainable urban mobility. The research integrates spatial planning analysis, bicycle traffic modelling, and an objective assessment of infrastructural solutions (Kharkiv case study). The approach focuses on developing technological principles for a rational bicycle infrastructure scheme that balances spatial constraints with residents' mobility needs and contributes to an inclusive urban environment. Special attention is given to dynamic bicycle traffic modelling using PTV VISSIM and to the evaluation of effectiveness using the intersection hazard index. Based on traffic flow analysis, a survey of local residents, existing national regulations, and international best practices, the study substantiates the social, environmental, and economic benefits of integrating cycling infrastructure. Results show that combining cycle lanes along the main highway with protected tracks at intersections reduces the traffic safety indicator (from 0.699 to 0.577), decreases average transport delays by over 106 seconds, and provides a significant environmental benefit. The positive economic effect and investment payback period confirm the feasibility of the proposed solutions. The findings are practically relevant for local authorities, design organizations, and civic initiatives involved in sustainable urban mobility planning.*

**Keywords:** bicycle infrastructure, sustainable urban mobility, transport planning, safety, ecological effect

**Introduction.** In the context of post-war reconstruction of Ukrainian cities, the priority of developing sustainable cycling infrastructure is growing, as a modern, safe bicycle network is a key element in creating resilient, inclusive urban spaces. Cycling is recognized as one of the most efficient and environmentally friendly components of sustainable urban mobility. It helps reduce traffic loads on the street-road network, decrease CO<sub>2</sub> emissions, and promote a healthy lifestyle among the population [1]. A developed, integrated, and safe cycling infrastructure in cities contributes to a gradual shift in citizens' daily mobility patterns, as demonstrated by the experience of European cities [2-3]. This role becomes strategically significant within the framework of the European Green Deal [4], the EU's main roadmap for achieving climate neutrality by 2050. As part of the "green transition", the European Union is actively implementing policies to increase the share of active modes of transport. The European Strategy for Sustainable and Smart Mobility [5] emphasizes that doubling cycling volumes across Europe by 2030 is particularly important. The urgent need to rebuild the transport system aligns with the European agenda of minimizing congestion, reducing environmental impacts, and decarbonizing the transport sector [6]. The European Sustainable and Smart Mobility Strategy and its key component, Sustainable Urban Mobility Plans (SUMP), highlight the need to prioritize active modes of travel as the foundation of a healthy, resilient, and energy-efficient city.

**Analysis of the latest research and problem statement.** In the period of post-war reconstruction of cities and the implementation of European transport policies into national legislation, the insufficient

development of cycling transport and infrastructure can be transformed into an advantage through strategic planning aligned with the documents that define the overall vector of sustainable transport development, which Ukraine follows in the process of European integration. When designing a rational cycling infrastructure, it is crucial to adhere to the principles of sustainable development to reduce energy and environmental costs, improve urban quality, and create conditions for safe and convenient movement for all road users. The EU Directive Guidelines for Developing and Implementing a Sustainable Urban Mobility Plan [7] defines a comprehensive approach to urban transport planning that prioritizes pedestrians and cyclists.

At the national level, the sustainable development system for communities has been aligned with the Ukrainian national standardization system through the National Standard ISO 37101:2019, "Sustainable development in communities". The obligation to plan cycling networks is established by the State Building Standards (SBS/DBN). These regulations define technical parameters related to safety and usability. An analysis of deviations between regulatory requirements and the actual condition of infrastructure (e.g., insufficient lane width or non-compliant turning radii) enables the identification of problematic sections. This serves as the basis for prioritizing modernization work, allowing the identification of which inconsistencies pose the most significant risk to user safety. However, an analysis of the current Ukrainian regulatory framework (in particular, DBN) indicates that it primarily governs design standards for individual segments of cycling infrastructure, thereby encouraging the separation of cycling flows from motor traffic. The standards are oriented toward existing demand (e.g., cycling lanes are required when traffic intensity exceeds 50 units/hour) and do not consider cycling transport as an integrated system, nor do they provide for strategic planning of a unified, coherent network, which contradicts the goal of increasing the cycling modal share [8].

International experience in cycling network planning (the Netherlands, Denmark, Germany, the USA) highlights key principles necessary for an effective network: maximum route directness, network connectivity, orientation toward trip purposes and user types, consideration of physical effort, and ensuring a high level of safety. These approaches can be reduced to two major strategies: the principle of spatial separation (Denmark, the Netherlands), which prioritizes safety by physically separating flows, and the principle of integration (Germany), which integrates cycling transport into the urban network through a combination of measures.

All national approaches rely on scientifically grounded principles for developing cycling networks. Based on recent scientific research, several actively studied directions can be identified: the design and resilience of cycling networks, interactions between cycling and public transport, factors influencing bicycle choice, and the specifics of cycling infrastructure development in Ukrainian cities.

Authors [9-10] consider cycling transport at the strategic planning level as an integral part of a multimodal system, integrated into the urban environment through the development of SUMPs. In this case, cycling is prioritized over private cars (the Modal Shift principle). In the research [11], safety is emphasized as a key factor in increasing cycling volumes. This is achieved through physical separation of cycling paths and the implementation of the Vision Zero concept, which underpins European directives. Researchers devote considerable attention to designing methodologies and evaluating the effectiveness of cycling networks. The models proposed in [12-13], developed using graph-theoretic and network analysis methods for route optimization, consider not only shortest distance but also safety, comfort, and route continuity. Authors [14] use GIS technologies and data on urban topography, building density, and attraction points to automate the selection of optimal corridors for constructing cycling paths. Studies [8, 15] focus on developing transport models to predict potential cycling demand based on infrastructure quality and its integration with public transport.

Ukrainian researchers have also intensified studies in this direction in recent years. They analyze the specifics of cycling transport planning in Ukrainian cities and factors influencing bicycle choice [8, 16-17]. However, an unresolved part of the overall problem remains the development of a comprehensive and adapted methodology for large Ukrainian cities - one that simultaneously considers the challenges of post-war reconstruction (speed, economic efficiency), ensures integrity and safety of the network in

accordance with European directives, and provides practical tools for demand modelling and optimal placement of cycling infrastructure within the existing car-oriented urban structure.

This shortcoming is critical for large cities in Ukraine, particularly Kharkiv. Despite the existence of general strategic documents such as SUMP (2024) and the Concept for the Development of Cycling and the Creation of Cycling Infrastructure in Kharkiv (2016), the task of developing practical tools for implementing these strategies at the local, engineering, and planning levels in the context of urban reconstruction remains unresolved. The lack of such methodologies complicates the informed choice of rational planning solutions based on the principles of sustainable development for individual streets in conditions of limited space. Thus, the development and testing of such a methodology, using a specific section of Kharkiv as an example, has significant scientific and practical value.

**The purpose and objectives of the research.** The purpose of the research is to develop an approach to planning cycling infrastructure in cities that is grounded in sustainable development principles. To achieve this purpose, the following tasks must be accomplished: to analyze existing strategic and regulatory documents; to determine development and implementation stages of a rational cycling infrastructure option on sustainable development principles; to determine effectiveness criteria for evaluating alternative options for developing bicycle infrastructure; to conduct a sociological survey of the resident's needs, preferences; to conduct an experimental study; to analyze the results of the research and select a rational option for cycling infrastructure; to determine effectiveness of solutions.

**Research materials and methods.** The object of the research is the process of forming a rational option for urban cycling infrastructure. The subject of the study is the influence of street and road network parameters on the sustainability of bicycle-based population movement. The development of cycling infrastructure requires detailed planning to support a comprehensive analysis of all its components, given the multifaceted nature of the process, which encompasses not only the physical construction of cycle paths and parking facilities but also regulatory and legal frameworks, planning, financing, information support, and community engagement.

In addition to the direct construction of bicycle routes, strategic planning that accounts for the urban environment's spatial, social, and functional characteristics is a critical component. Efficient cycling infrastructure should meet the needs of different user groups (local residents) and ensure safe travel, even in areas with heavy traffic. It also requires accompanying navigation, bicycle storage facilities, convenient transfer hubs, and information support to promote cycling as a fully-fledged mode of transport. Only a combination of physical, organisational, regulatory, social, and technological solutions can create an effective cycling system that complies with the principles of sustainable mobility. Each structural element has its own specifics and implementation requirements, which must be considered when developing specific projects and development programmes.

The type of cycling infrastructure and the technical parameters of each cycle path (width, surface, colour, markings) are determined by the project (plan) individually for each street, taking into account local conditions and the requirements of state standards, and can be implemented in the following forms: cycle lanes; one-way cycle path; two-way cycle path; one-way cycle and pedestrian path; two-way cycle and pedestrian path.

When designing cycling infrastructure, it is crucial to make an informed choice between these types of cycling arrangements, particularly between carriageway cycle lanes and separate cycle paths. Cycle lanes have the advantage of being easy to implement in limited space and at minimal cost. Still, they are inferior to cycle paths in terms of safety, conflict, and comfort. Separate cycle paths provide a higher level of safety and better integration with the urban transport system, but require more space and resources to implement. The final decision should be based on a balance between the spatial, financial, and functional constraints of the implementation site in accordance with approved strategic concepts for the development of sustainable urban mobility.

Urban development concepts, in particular the Cycling Concept [18], provide a strategic framework for analysis. They define key performance indicators such as the planned length of cycle paths, implementation deadlines, and expected results. For example, comparing actual construction rates with

planned rates can reveal systemic problems in project management, such as insufficient funding or poor coordination between services.

State building regulations establish technical parameters for safety and usability. An analysis of discrepancies between regulatory requirements and the actual state of the infrastructure (e.g., insufficient lane widths or inappropriate turning radii) enables the identification of problem areas. This provides a basis for prioritizing modernization work by identifying nonconformities that pose the most significant risk to user safety.

DSTU standards detail the requirements for individual infrastructure elements. They cover aspects such as road surface quality, road sign visibility, and parking space ergonomics. A systematic comparison of actual indicators with regulatory ones enables not only the identification of shortcomings but also the proposal of technically sound solutions. For example, if measurements show that the road surface has insufficient grip, this may be grounds for replacing it with a higher-quality material.

Traffic rules and traffic management instructions form the legal basis for analyzing the behavior of road users. Research on compliance with these standards (e.g., the frequency with which cyclists ride on the carriageway in the absence of cycle paths) enables us to assess the effectiveness of existing infrastructure and identify areas for improvement. Such data is particularly valuable when planning new routes or adjusting existing ones.

The integration of the regulatory framework into the study ensures its scientific validity and practical relevance. It allows us to move from general observations to specific recommendations, each supported by official requirements. This is particularly important when justifying the need for change to local authorities or potential investors. For example, references to specific points in DBN or DSTU significantly increase the weight of arguments for reconstructing a particular section. One of the key factors in the success of bicycle infrastructure planning is compliance with national standards and requirements, particularly DSTU 8906:2019, which establishes design standards for cycle paths and other infrastructure elements. According to this standard, the design of cycling infrastructure should provide safe and convenient conditions for cyclists, including dedicated cycling lanes, bicycle parking, and maintenance. In addition, the infrastructure should be integrated into the city's overall transport network, ensuring convenient access to key locations and connections to other modes of transport. At the international level, a key focus is the application of urban planning principles to bicycle infrastructure, particularly in medium- and large-sized cities. The success of bicycle transport development there is based on a systematic design approach that includes safety, comfort, connectivity, and social and cultural change.

The results of public discussions and the opinions of all stakeholder groups in the city should guide the development of cycling infrastructure. Taking into account the views of cyclists, pedestrians, drivers, business representatives, local authorities, and relevant public organizations is essential to designing effective, high-quality infrastructure that is well-received. Ignoring the views of even one of these groups can lead to conflict, inefficient resource use, and low facility utilization.

Studying the opinions of different participant groups allows us to determine the population's needs for cycling infrastructure at the district, street, intersection, and city levels, and to identify key interrelationships among these aspects and develop practical solutions. For example, surveys can reveal not only desirable locations for bicycle parking near metro stations or shopping centers, but also less obvious needs for safe crossings at complex transport junctions and for integrating bicycle routes with pedestrian areas. Understanding these interrelationships is critical to a systematic approach to bicycle infrastructure development, rather than just addressing individual issues.

Figure 1 presents a diagram of the relationships among participants (stakeholders) in the decision-making process for creating bicycle infrastructure based on sustainable mobility principles, from public initiatives through the implementation of the finished facility.

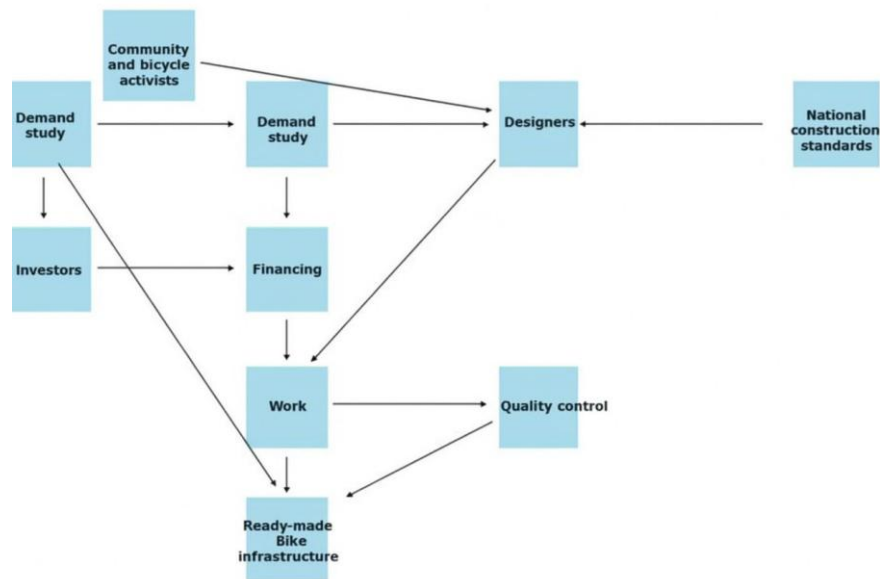

**Fig. 1. Scheme of interaction between participants in the cycling infrastructure planning process**

The diagram covers the participants and all the main stages of developing and implementing cycling infrastructure based on the principles of sustainable development: demand analysis, design, financing, construction, quality control, and commissioning, and shows the interaction between key participants (the public, local authorities, investors, designers, builders, and quality controllers), which are shown in Figure 2. The structure allows you to follow the sequence of stages in detail and analyse the potential influences among different participants, from public initiatives and cycling activists to established cycling infrastructure.

The first step is to study demand based on feedback from city residents and active bicycle users. Based on these data, local authorities engage designers who, in turn, adhere to state construction standards.

At the same time, funding is sought from investors and local authorities. Once the design phase is complete and funding has been secured, implementation of the project begins. Quality control ensures the project complies with standards and requirements, thereby guaranteeing the durability and safety of the infrastructure. At the end of this process, a rational version of the cycling infrastructure is formed, the result of coordinated cooperation among the public, government agencies, investors, and technical specialists. This sequence of stages enables a comprehensive study of the project, accounting for both technical and social factors.

Among the methods for developing a rational bicycle infrastructure option in cities, the following can be highlighted: physical modeling, mathematical modeling, simulation modeling, and statistical modeling. Based on an analysis of the advantages and disadvantages of these methods, it was determined that comprehensive modeling that integrates physical analysis and statistical data enables assessment of critical areas. Compliance with standards, consideration of public opinion, and adaptation of international experience will ensure the high-quality development of the bicycle network.

The choice of a rational option should be based not only on technical feasibility but also on the maximization of social, transport, and environmental benefits. A safe environment is a prerequisite for the development of cycling. In urban areas with high car traffic density and congested street and road networks, safety levels determine residents' willingness to switch to cycling. Where cyclists feel vulnerable or isolated, the use of this mode of transport declines, regardless of other advantages such as route accessibility, travel speed, or cost savings. If the cycling conditions are safe, even a less convenient or longer route becomes attractive to users.

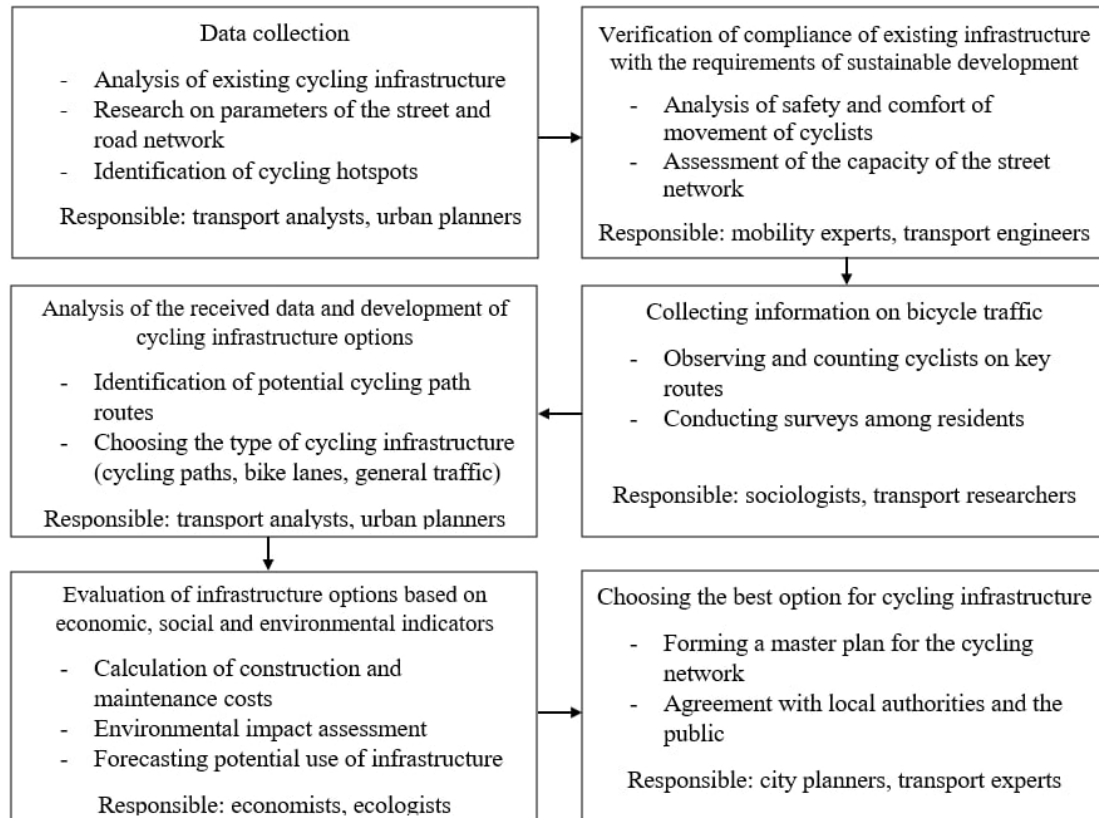

**Fig. 2. Development and implementation stages of a rational cycling infrastructure option on sustainable development principles**

According to 2024 statistics from the Ukrainian Patrol Police, the proportion of road traffic accidents (RTAs) involving cyclists was nearly 6%. Planning the development of cycling infrastructure from the perspective of user safety has a long-term impact in the form of:

- a reduction in CO<sub>2</sub> emissions and other pollutants due to a decrease in the proportion of cars in urban traffic as some residents switch to bicycle transport. However, these changes will be effective only if the infrastructure ensures the safety of bicycle use;

- rational infrastructure decisions can be more cost-effective in the long term, even if the initial implementation costs are higher. This can be achieved by increasing the appeal of bicycle transport as a cheap and efficient mode.

- safe cycling infrastructure, especially at intersections, allows the city to avoid significant economic losses from the consequences of traffic accidents.

- the availability of a safe environment for travel stimulates sustainable tourism, urban initiatives, and the attractiveness and development of the city.

The rationale for the safety criterion also reflects the contemporary philosophy of human-centered urban design. This approach has become the basis for many transport policies worldwide and is enshrined in Ukraine's national regulatory documents. It enables the creation of infrastructure that not only fulfils a technical function but also shapes a new transport culture in which bicycles are perceived as a fully-fledged and safe means of transport.

Therefore, as a criterion of effectiveness, we propose considering the traffic safety indicator, which accounts for accident risks and characterizes the level of danger at intersections

$$K_a = \frac{G \cdot K_p \cdot 10^7 \cdot k_r}{(M + N) \cdot 25} \rightarrow \min, \quad (1)$$

where  $G$  is the theoretically probable number of accidents at an intersection in one year;  
 $K_P$  is the coefficient of annual traffic unevenness (we assume  $Kr = 0.12$ );  $M$  is the traffic intensity on the main road, vehicles per day;  
 $N$  is the traffic intensity on the secondary road, vehicles per day.

This indicator is the basis for creating a safe, sustainable, convenient, and attractive urban space where cyclists feel like equal participants in traffic. All further technical and economic justifications and project decisions will be made with this criterion in mind.

The organization of safe and efficient bicycle traffic in the urban street and road network is impossible without proper intersection design, areas with high accident rates, and dense interactions among all road users. In this context, special attention should be paid to the analysis of the interphase period—the interval between the end of one traffic light signal and the start of another—which plays an essential role in ensuring safety when changing direction, particularly when vehicles turn and cyclists cross paths.

A variety of methods are used to determine the risk of accidents at intersections. We suggest using the conflict point method [18], based on the analysis of the points of intersection between the trajectories of conflicting vehicles, primarily to assess safety in urban areas

$$q_i = \frac{K_i \cdot M_i \cdot N_i \cdot 25 \cdot 10^{-7}}{k_H \cdot K_p}, \quad (2)$$

where  $i$  is the number of conflict points;

$M_i$ ,  $N_i$  are the intensities of traffic flows interacting at this point, vehicles/hour;

$K_i$  is the coefficient of relative accident rate of the conflict point, accidents/ $10^7$  vehicles.

The overall danger level of an intersection is an additive indicator, determined as the sum of the danger levels of all conflict points at the intersection.

The task of comprehensively assessing traffic safety is addressed in several stages for each alternative intersection design: in the absence of bicycle infrastructure, with the introduction of a cycle lane, and with the construction of a full-fledged cycle path. In the first stage, accident rates are determined for each potentially conflict point at the intersection, based on the nature of interactions among road users (pedestrians, cyclists, and vehicle drivers) and traffic intensity. At the second stage, using the obtained coefficients, a generalized traffic safety indicator ( $K_a$ ) is calculated for each option under consideration. The  $K_a$  value is used to assess the danger at the intersection. If  $K_a \leq 3$ , the intersection is safe; if  $3 < K_a \leq 8$ , the intersection is almost safe; if  $8 < K_a \leq 12$ , the intersection is dangerous; if  $K_a > 12$ , the intersection is perilous. Next, to justify the most rational engineering solution, an alternative comparison is conducted using the generalized traffic safety indicator. When developing a rational bicycle infrastructure option for a city, one key task is to assess the effectiveness of the proposed solutions. Accurate quantitative forecasting of the reduction in private car trips following the introduction of bicycle infrastructure is difficult because it requires accounting for all the factors that influence changes in the population's transport behavior. In this regard, it is best to focus not on the absolute reduction in car traffic, but on the potential environmental impact by analyzing changes in pollutant emission levels, and on the possible social effect by reducing vehicle delays at intersections. To model these indicators for alternative bicycle infrastructure options, we propose using PTV VISSIM traffic modelling software, which enables the reproduction of traffic patterns of all road users at a microscopic scale and the simulation of the impacts of traffic light phases, congestion, queues, waiting times, and pollution intensity [1].

We assess the social effect of implementing a rational bicycle infrastructure option using the indicator of annual transport time spent on the section

$$\Delta T_3^{pic} = \frac{365 \cdot N_{sum} \cdot \Delta \bar{t}_{\Delta H}}{3600 \cdot k_H}, \quad (3)$$

where  $N_{sum}$  is a total traffic intensity of all vehicles at the intersection, cars/hour;

$\Delta \bar{t}_{\Delta H}$  is the change in the average delay of vehicles at the intersection after the implementation of the proposed measures, s;

$k_H$  is the coefficient of transition from hourly traffic intensity to daily traffic intensity (it is recommended to take  $k_H=0,1$ ).

The annual socioeconomic effect of reducing vehicle delay time on the section under consideration is estimated using the cost of 1 hour of driver/passenger time (assumed to be 40% of the current year's hourly wage rate).

To conduct a quick comparative assessment of the ecological effect per hour of vehicle movement per 1 km of road, based on modelling harmful emissions volumes, it is advisable to use the methodology [19]

$$\Delta E_i = \left[ \sum_{i=1}^n C_i \cdot (g_{i\ exist} - g_{i\ rational}) \cdot k_i \cdot N_i \right] \cdot 10^{-6}, \quad (4)$$

where  $C_i$  is the damage from the emission of one tonne of the  $i$ -th pollutant, UAH/tonne;

$g_{i\ exist}$ ,  $g_{i\ rational}$  is specific emissions of the  $i$ -th pollutant by the main car models in comparable road traffic conditions, g/km;

$k_i$  are a correction coefficients for the transition from basic car models to those studied during the calculation of harmful emissions and fuel consumption;

$N_i$  is the number of cars of the specified model passing through a section of road within an hour.

As is well known, developing cycling infrastructure requires significant capital investment. The average payback period for capital investments in cycling infrastructure depends on the scale of the project, local conditions, the volume of use of cycle lanes, and the methodology used to assess the effect. However, the experience of EU countries shows that, in most cases, the average payback period for cycling infrastructure is between 3 and 10 years.

The payback period for cycling infrastructure on the section of the street-road network under consideration is determined by the ratio of total investment costs to the annual economic effect, including socio-economic and ecological effects

$$T_{PB} = \frac{K}{\sum E} \quad (5)$$

where  $K$  is the capital investment for the establishment of 1 km of cycling infrastructure.

The implementation of the proposed approach is illustrated by the example of the street-road network of Kharkiv (a section of Silikatna Street). The city authorities, guided by international experience and national standards, incorporate European approaches into their bicycle transport development concept, particularly through public information and support for sustainable mobility. The area's characteristics are conducive to the development of pedestrian and micromobility traffic. Pedestrian traffic is popular among Kharkiv residents. At the same time, micro-mobility is primarily undertaken by the population on bicycles for domestic and recreational purposes. According to open data, walking accounts for approximately one-third of the modal split in Kharkiv. Analysis of cycling intensity data shows that most cyclists use it as a full-fledged individual mode of transport. The priority direction for the development of cycling in Kharkiv is to connect the most densely populated areas of the city and the largest centers of attraction. Given the remoteness of residential areas from the city center, it is necessary to ensure that routes are as short and direct as possible, with minimal disruption to bicycle traffic.

Silikatna St. is located in the Osnovyanskyi district and reflects the district's typical mixed urban structure. The Osnovyanskyi district is located in the southern part of the city and combines historical development, industrial areas, and modern residential neighborhoods. The district is centered on the historic area of Osnova. It is distinguished by distinctive natural and landscape features, owing to its location at the confluence of the Lopan and Kharkiv rivers. This creates a well-developed network of recreational spaces. Elevated risks for road users - typical for streets in this district are driven by intense motor vehicle traffic, insufficient systems for transport prioritization, suboptimal traffic light operation, and the absence of informational signage for micromobility users, including cyclists. These risks increase further at night due to inadequate lighting on both the roadway and the sidewalks. Typical streets in this district exhibit a diverse development pattern, combining multi-storey residential buildings with low-rise private housing. Such a layout increases demand for convenient, safe, and efficient transport solutions, including cycling routes as alternatives to car travel (Fig. 3). The varying density of development generates demand for cycling routes as an alternative to motorised transport, as well as the potential to develop local bicycle paths that are comfortable for residents of the private housing sector. This requires adapting infrastructure solutions to the specific characteristics of each zone.



**Fig. 3. Current condition of the road surface on Silikatna St. (Kharkiv)**

Silikatna St. in Kharkiv has basic public transport connections to other parts of the city. Bus services connect the metro station to the recreational area and provide convenient connections between different parts of the city; however, bus intervals exceed 30 minutes. A trolleybus route additionally covers this part of the city, providing an alternative to bus services. The tram line is far from the area. Thus, this street lacks adequate transport connections, as it is served primarily by bus and trolleybus routes. The development of cycling infrastructure on this street could significantly improve transport accessibility for residents of neighboring areas, reduce congestion, and enhance the urban environment.

An alternative route for cyclists is often the sidewalk, which is not designed for bicycle traffic. This situation results in frequent conflicts between cyclists and pedestrians, particularly in areas with high pedestrian traffic. This once again highlights the lack of a well-thought-out and balanced transport policy at the district level.

In addition to the lack of cycle paths and lanes, the district lacks supporting infrastructure to promote bicycle use and convenience (e.g., bicycle parking areas, navigation and information signs). This significantly limits the use of bicycles as a daily means of transport for a wide range of residents and exacerbates social inequality across segments of the population, including children, young people, the working population, the elderly, people with disabilities, and people on low incomes. In addition, the complete lack of conditions for bicycle transport adversely affects the overall mobility of the population, contributes to motorization, exacerbates environmental problems, and contradicts the principles of urban mobility development grounded in sustainable development, which modern European cities strive to achieve.

To research the population's needs for cycling infrastructure on Silikatna St., a survey was conducted among residents and visitors to the area. Forty-one respondents of different ages, statuses, and modes of

transportation were interviewed. The results allowed us to assess the current situation and identify residents' problems and expectations. Most respondents (42%) consider the current situation dangerous for cyclists and express support for the creation of safe, separate cycle paths, bicycle parking facilities, and appropriate markings. A significant proportion of respondents (63%) are also willing to use bicycles more often if high-quality infrastructure is available. These results demonstrate the importance of designing bicycle infrastructure as part of comprehensive street and neighbourhood development, thereby promoting sustainable mobility for the population.

The intersection of Silikatna St., Kamianetskyi v'ezd, and Rudynska St. in Kharkiv was selected for research due to its strategic location and characteristic features that reflect typical problems of bicycle traffic organization in urban areas. This intersection connects a residential area with industrial and recreational areas, resulting in dynamic traffic from various groups of road users, including pedestrians and cyclists. In addition, the availability of spatial reserves in street cross-sections creates opportunities for implementing bicycle infrastructure elements. That is why this intersection is a good example for analyzing the impact of the street network's geometric parameters on the feasibility of integrating sustainable solutions to organize bicycle traffic.

Based on field survey data, the intensity and composition of traffic flow (vehicles, bicycles, and pedestrians) at this intersection were obtained to support a comprehensive safety assessment of two alternative options for bicycle infrastructure development: constructing cycle paths and constructing cycle lanes.

To comprehensively assess the safety of each intersection design option, a step-by-step calculation was performed using the proposed methodology. At the first stage, accident rates were determined for each potentially conflict point in the intersection based on the nature of interactions among traffic participants (pedestrians, cyclists, and vehicle drivers) and traffic intensity. Next, based on the results, a generalized traffic safety indicator was determined for each of the considered options. Based on the selected efficiency criterion, it was determined that, under the existing option (without bicycle infrastructure), this intersection is classified as very dangerous ( $K_{a\ exist}=15,4$ ). According to the option of equipping this section of the street with a cycle path, the intersection is classified as very dangerous ( $K_{a\ path}=12,7$ ). In contrast, with the installation of a cycle lane, the level of danger increases to ( $K_{a\ lane}=13,1$ ). However, the overall level of danger at the intersection measured by conflict points decreases from 0.6997 to 0.595 when cycle lanes are set up and to 0.577 when cycle paths are set up. This demonstrates that implementing cycle paths at intersections will be more effective.

The results confirm the hypothesis that integrating cycle lanes not only improves safety but also does not create significant obstacles to the overall operation of traffic light control. Taking into account the current regulatory documents on the design of traffic light systems, a rational option for developing bicycle infrastructure on such typical streets is to combine cycle lanes along the main route with cycle lanes within intersections. This approach is justified because the street's width does not permit the construction of full-fledged cycle paths along the entire length of the route without significant interference with existing buildings or a reduction in motor-vehicle traffic lanes, which is contrary to the regulations. Cycle lanes within the carriageway are an acceptable and recommended solution for streets with limited space. At the same time, at intersections where the intensity of conflict between road users increases, it is advisable to allocate separate cycle lanes to improve cyclists' safety and to implement distinct traffic zoning.

Therefore, the most rational option for cycling infrastructure on Silikatna St. is a combined option: constructing a cycle line and installing cycle paths at intersections, which will reduce traffic congestion without compromising road-user safety and minimize environmental impact. The proposed solution, grounded in sustainable mobility principles, underscores the need for an approach to developing a sustainable urban bicycle network.

As part of the research, simulation modelling was conducted using PTV VISSIM. Two transport models were developed for the typical intersection in the Kharkiv case study: one without a dedicated bicycle space (Fig. 4) and one with a dedicated bicycle infrastructure (Fig. 5).

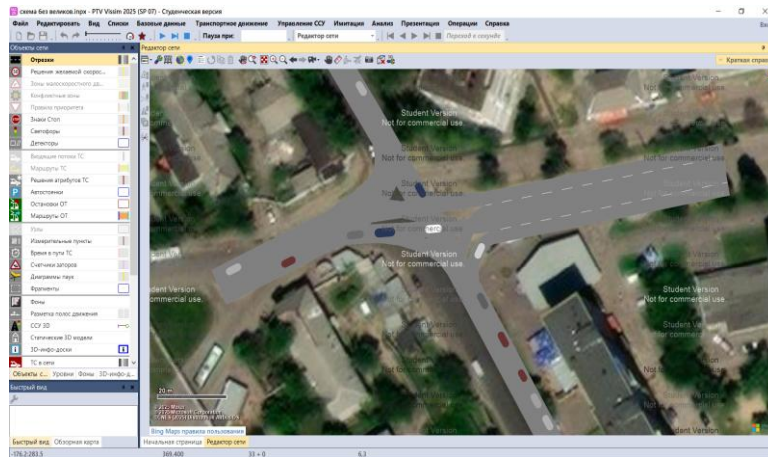

Fig. 4. Transport model of the intersection without a separate space for cyclists in the PTV VISSIM software

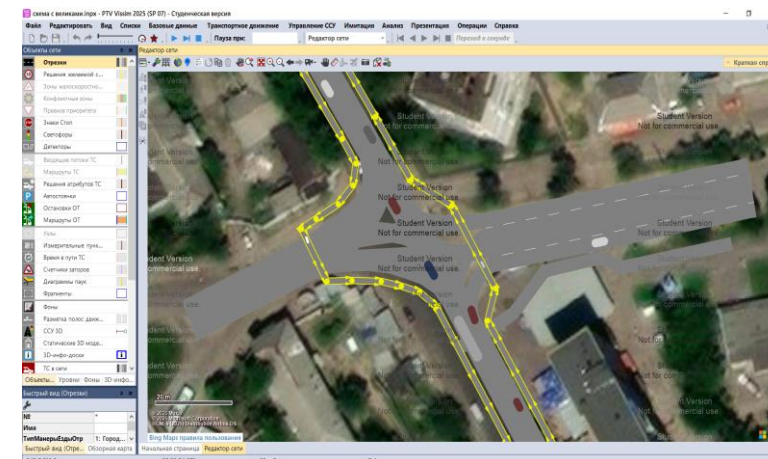

Fig. 5. Transport model of the intersection with a separate space for cyclists in the PTV VISSIM software

The modelling was based on established quantitative and qualitative characteristics of vehicle traffic, derived from hourly intensity and composition data on Silikatna St. The simulation results yielded values for 17 indicators across 17 segments, including vehicle delays, pollutant emissions, and fuel consumption per 1 km travelled. The statistical characteristics of the simulated parameters are presented in Table 1.

Table 1. Results of the estimation of statistical characteristics of simulated parameters

Name of indicator	Value of the indicator			
	Mathematical expectation		Mean squared deviation	
	Existing	Rational	Existing	Rational
Vehicle delay time, s/km	149,55	43,67	318,85	12,06
Total emissions of pollutants per hour, g/km	17,65	8,20	49,22	4,56

As a result of transport process modeling, it was established that introducing bicycle infrastructure on Silikatna St. would reduce average transport delays by more than 106 seconds and reduce harmful emissions by 50%. The results of annual environmental damage calculations indicate that passenger cars have the most significant adverse ecological impact among all vehicle types, with annual damage from their operation amounting to 4.5 thousand UAH/km, owing to their considerable share (537 units) of total traffic. The total yearly ecological effect of implementing a rational bicycle infrastructure option on Silikatna St. for a 1 km section considered in the modeling is 2,900 UAH/km.

The annual socio-economic effect of reducing vehicle delay time is 4.019 thousand UAH, estimated based on the cost of 1 hour of driver/passenger time. The total economic impact of implementing a rational bicycle infrastructure option is 4024.9 thousand UAH per 1 km, with a 5-year payback period, which corresponds to the average payback period for investments in bicycle infrastructure development in European Union countries and demonstrates the effectiveness and feasibility of the proposed solution.

**Conclusions.** In this paper, an approach to planning bicycle infrastructure in cities based on sustainable development principles was proposed. The study focused on a detailed examination of the planning process for bicycle infrastructure as an integral component of sustainable urban mobility. Special attention is paid to the justification of bicycle traffic modeling methods, which enables not only the identification of critical areas but also the objective assessment of the effectiveness of the proposed solutions. The integration of statistical analysis, consideration of community needs, theoretical approaches, and physical modeling practices has established a scientifically grounded basis for planning bicycle infrastructure that accounts for current regulations and standards.

The analysis of stakeholder interaction across all stages of planning and implementation shows that the effective operation of bicycle infrastructure is impossible without well-established cooperation among local authorities, project organizations, investors, construction companies, community activists, and residents.

The proposed approach is examined using a typical section of Kharkiv's street-road network as an example (on Silikatna St.). The assessment of the current state of the network, particularly in the city's residential and industrial areas, indicates fragmentation and a critical shortage of bicycle infrastructure. Primarily, this increases risks at intersections for all road users, particularly cyclists and micromobility users. Therefore, there is an urgent need to develop approaches for planning justified, safe, and functional infrastructure solutions.

Safety is a key factor that encourages the use of bicycles as an everyday mode of transportation, which defines the choice of the efficiency criterion. The road safety indicator assesses the risk of traffic accidents in planning bicycle infrastructure, employing a systemic approach that focuses on objective performance indicators and residents' needs to create a sustainable, comfortable, and safe urban environment.

Based on the efficiency criterion, it was determined that, when developing alternative options for bicycle infrastructure at the intersection, the overall level of danger decreases from 0.6997 to 0.577 when a bicycle lane is implemented. However, given the current regulatory documents and spatial planning for a typical section of the network, the most rational option for bicycle infrastructure is a combination of bicycle lanes along the main street corridor and bicycle paths within intersections. Bicycle lanes, as part of the roadway, are an acceptable and recommended solution for streets, particularly in situations with limited space. At the same time, at intersections where the intensity of conflict points between road users increases, it is advisable to allocate separate bicycle paths to enhance cyclist safety and to implement distinct traffic zoning.

The proposed planning approach, based on analyses of the transport situation, spatial planning, and the assessment of the effectiveness of the proposed solutions, enabled justification not only of the technical feasibility but also of the social, environmental, and economic benefits of integrating a bicycle component into the urban transport system. The positive results of the financial impact assessment confirm the effectiveness of the solutions proposed in the research.

The results of this study could inform a new urban transport policy focused on inclusiveness, environmental sustainability, and improved residents' quality of life.

## REFERENCES

1. Kholodova, O., Buhaiova, M. (2025). *Modeling and Evaluation of the Effectiveness of Modern Methods of Traffic Management in Urban Street and Road Networks: monohrafiia /red. prof. I. S. Nahliuka*. Kharkiv. [in Ukrainian].
2. Qiu, L.-Y., He, L.-Y. (2018) Bike Sharing and the Economy, the Environment, and Health-Related Externalities. *Sustainability* 2018, 10, 1145. <https://doi.org/10.3390/su10041145>.
3. Zhao, C., Carstensen, T.A., Nielsen, T.A.S., Olafsson, A.S. (2018) Bicycle-friendly infrastructure planning in Beijing and Copenhagen - between adapting design solutions and learning local planning cultures. *Journal of Transport Geography*. 2018, 68, 149–159. <https://doi.org/10.1016/j.jtrangeo.2018.03.003>.
4. European Commission. (2019). European Green Deal.
5. European Commission. (2020). Sustainable and Smart Mobility Strategy – putting European transport on track for the future.
6. Potaman, N., Orda, O., & Orda, O. (2024). Analysis of Sustainable Urban Mobility Planning Aspects in the Context of European Integration Reforms in Ukraine. *Central Ukrainian Scientific Bulletin. Technical Sciences*, 10(41(2)), 188-195. [https://doi.org/10.32515/2664-262X.2024.10\(41\).2.188-195](https://doi.org/10.32515/2664-262X.2024.10(41).2.188-195). [in Ukrainian].
7. European Commission. (2019). Guidelines for developing and implementing a Sustainable Urban Mobility Plan (2nd ed.).
8. Ukrainian State Standard ISO 37101:2019. Sustainable development in communities. Management system. General principles and requirements with guidance for use. (2019). International Organization for Standardization. [in Ukrainian].
9. Ministry of Regional Development, Construction, Housing and Communal Services of Ukraine. (2018). DBN V.2.3-5:2018. Streets and roads of settlements (With Amendment No. 1). Official publication. [in Ukrainian].
10. Ministry of Regional Development, Construction, Housing and Communal Services of Ukraine. (2015). DBN V.2.3-4:2015. Highways. Part I. Design. Part II. Construction. Official publication [in Ukrainian].
11. Ministry of Economic Development and Trade of Ukraine. (2019). DSTU 8906:2019. Planning and design of bicycle infrastructure. General requirements. [in Ukrainian].
12. Chernyshova, O. S. (2019) Development of cycling network in cities with low level of cycling. *Doctor's thesis*. Kharkiv', 207 [in Ukrainian].
13. Litman, T., 2021. Evaluating Public Transit Benefits and Costs: A Best Practices Guidebook, *Victoria Transport Policy Institute*. Canada. <https://coilink.org/20.500.12592/fe5jt2>.
14. Torrisi, V., Garau, C., Ignaccolo, M., & Inturri, G. (2020, July). “Sustainable urban mobility plans”: key concepts and a critical revision on SUMP guidelines. In *International conference on computational science and its applications* (pp. 613-628). Cham: Springer International Publishing. [https://doi.org/10.1007/978-3-030-58820-5\\_45](https://doi.org/10.1007/978-3-030-58820-5_45).
15. Pucher, J., & Buehler, R. (2017). Cycling towards a more sustainable transport future. *Transport Reviews*, 37(6), 689-724. <https://doi.org/10.1080/01441647.2017.1340234>.
16. Barati, H., Yazici, A., & Almotahari, A. (2024). Graph Neural Networks Model to Generate Transportation Test Networks. *Transportation Research Record*, 2678(10), 435-448. <https://doi.org/10.1177/03611981241233569>.
17. Miah, M. M., Mattingly, S. P., & Hyun, K. K. (2023). Evaluation of bicycle network connectivity using graph theory and level of traffic stress. *Journal of transportation engineering, Part A: Systems*, 149(9), 04023080. <https://doi.org/10.1061/JTEPBS.TEENG-7776>.
18. Özkan, S. P., Şenol, F., & Özçam, Z. (2020). Bicycle Route Infrastructure Planning Using GIS in an Urban Area: The Case of İzmir. *Planlama*, 30(2), 313-327. <https://doi.org/10.14744/planlama.2020.41275>.
19. Oskarski, J., Birr, K., & Żarski, K. (2021). Bicycle Traffic Model for Sustainable Urban Mobility Planning. *Energies*, 14(18), 5970. <https://doi.org/10.3390/en14185970>.
20. Fomenko H.R. (2024) Bicycle Transport And Its Development In Urban Centers. *Vcheni zapysky TNU imeni V.I. Vernadskoho. Serii: Tekhnichni nauky*, 35(74(6)), 288-292 [in Ukrainian].
21. Prokopchuk, I., & Gladkykh, V. (2022). Cycling in the context of state transport policy: Modern challenges. *Naukovi perspektyvy*, 5(23), 127–142. [https://doi.org/10.52058/2708-7530-2022-5\(23\)-127-142](https://doi.org/10.52058/2708-7530-2022-5(23)-127-142). [in Ukrainian].
22. Concept of development of cycling and bicycle infrastructure in Kharkiv.
23. Barhouni, O., Zaki, M. H., & Tahar, S. (2024). A formal approach to road safety assessment using traffic conflict techniques. *IEEE Open Journal of Vehicular Technology*, 5, 606-619. <https://doi.org/10.1109/OJVT.2024.3387414>.
24. Lynnyk, I., Lezhneva, O., Dorozhko, Ye., Vakulenko, K., Sokolova, & N., Afanasieva, I. (2020). *Ecological aspects of the road transport complex: monohrafiia*. Kharkiv.

**Олександра Орда<sup>1</sup>, Єгор Голубнічій<sup>2</sup>**

<sup>1</sup>Кандидат технічних наук, доцент, доцент кафедри «Транспортні технології», Харківський національний автомобільно-дорожній університет, вул. Ярослава Мудрого, 25, м. Харків, 61002, Україна. ORCID: <https://orcid.org/0000-0002-7213-8469>.

<sup>2</sup>Магістр, Харківський національний автомобільно-дорожній університет, вул. Ярослава Мудрого, 25, м. Харків, 61002, Україна. ORCID: <https://orcid.org/0009-0004-0216-3687>.

## **Планування велосипедної інфраструктури для сталої міської мобільності: тематичне дослідження Харкова**

**Анотація.** У контексті повоєнної реконструкції українських міст пріоритетність розвитку сталої велосипедної інфраструктури зростає, оскільки створення сучасної та безпечної веломережі є ключовим елементом формування стійких і інклюзивних міських просторів. У статті представлено комплексний підхід до стратегічного планування велосипедної інфраструктури як важливої складової сталої міської мобільності. Дослідження охоплює аналіз просторових умов, моделювання велосипедного руху та оцінювання ефективності інженерних рішень в місті Харкові (на прикладі вул. Павла Тичини). Запропонований підхід передбачає обґрунтування раціонального варіанту велоінфраструктури з урахуванням наявних обмежень вуличного простору та потреб мешканців у безпечному та комфортному пересуванні, що дозволить зменшити залежність населення від приватного автотранспорту. Особливу увагу приділено застосуванню динамічного моделювання у середовищі PTV VISSIM та використанню індикатора рівня небезпеки перехресть для кількісної оцінки ефективності. Результати аналізу транспортних потоків, соціологічного опитування та адаптації зарубіжних практик підтверджують значний соціальний, екологічний і економічний ефект від впровадження запропонованих рішень. Зокрема, поєднання велосмуг уздовж основного маршруту з облаштуванням велодоріжок у межах перехресть дозволило зменшити показник небезпеки перехрестя, скоротити затримки транспорту та отримати екологічний ефект. Отримані результати можуть бути використані органами місцевого самоврядування, проєктними організаціями та громадськими ініціативами під час планування сталої міської мобільності.

**Ключові слова:** велосипедна інфраструктура, сталий міський транспорт, транспортне планування, безпека, екологічний ефект

*Дата першого надходження статті до видання 21.10.2025*

*Дата прийняття до друку статті 24.11.2025*

UDC 629.4

**Andrii Zalata**<sup>1\*</sup>

<sup>1</sup>Postgraduate student, Maintenance and Repair of Rolling Stock Department, Ukrainian State University of Railway Transport, 7, Feuerbach Square, Kharkiv, 61050, Ukraine. ORCID: <https://orcid.org/0009-0003-0557-795X>.

\*Corresponding author: [zalata.ac@gmail.com](mailto:zalata.ac@gmail.com).

## Methodology for Training a Neuro-Fuzzy Control System for a Diesel-Generator Unit Under Variable Operating Conditions

*This paper presents a methodology for constructing and training a neuro-fuzzy control system for a diesel-generator unit operating under variable railway conditions. Modern traction power units encounter significant fluctuations in operational factors such as train mass, track profile, and section length, which necessitate adaptive regulation of power output. Traditional control systems are limited in their ability to respond to complex multifactor dynamics, motivating the use of hybrid intelligent systems. The proposed approach integrates Fuzzy C-Means (FCM) clustering to determine the initial structure of the fuzzy rule base and to form Gaussian membership functions based on cluster centers. A hybrid learning strategy is implemented, combining backpropagation and stochastic gradient descent to adjust both the fuzzy and neural components of the model. This enables the system to refine membership parameters, optimize rule interactions, and adapt to nonlinearities in the operational data. The developed neuro-fuzzy model is validated using test samples not included in the training dataset. The results demonstrate high approximation accuracy and strong generalization capability, with prediction errors remaining within acceptable limits. The model effectively reproduces optimal control actions across diverse operating scenarios. The proposed methodology is suitable for integration into traction energy control systems and provides a foundation for future enhancements through expanded datasets, improved optimization algorithms, and full-scale simulation or field testing.*

**Keywords:** diesel-generator unit, intelligent control, neuro-fuzzy systems, machine learning, autonomous rolling stock.

**Introduction.** The increasing complexity of modern railway transport systems places new demands on the efficiency, reliability, and adaptability of traction power units. Diesel-generator installations, which remain a key component of locomotive power systems on non-electrified or partially electrified lines, are required to operate under highly variable conditions that can change drastically over short distances. These variations arise primarily from fluctuations in train mass, differences in track profile, and the length of operational sections, all of which directly influence the traction load and the dynamic behavior of the power unit. Under such circumstances, maintaining stable generator operation, ensuring fuel-efficient performance, and preventing overloads becomes a multifaceted control problem.

Traditional control approaches, often based on fixed-parameter regulators or simplified analytical models, demonstrate limited effectiveness when exposed to the nonlinear and rapidly changing dynamics of real railway operation. They lack the ability to interpret complex interactions between multiple operational factors and cannot provide timely adaptation of control actions. As a result, suboptimal power distribution, increased fuel consumption, and accelerated wear of engine components are commonly observed, especially under demanding operational scenarios.

In contrast, intelligent control systems – particularly those integrating fuzzy logic and neural-network learning – offer significant advantages in handling the nonlinearities and uncertainties inherent in diesel-generator operation. Fuzzy logic enables the incorporation of expert knowledge and heuristic rules, while neural networks provide adaptability through data-driven learning. Combining these approaches within a neuro-fuzzy framework makes it possible to construct controllers capable of real-time adaptation, improved generalization, and robust performance under diverse conditions.

However, developing a high-performance neuro-fuzzy control system is a nontrivial task. It requires the proper definition of the fuzzy knowledge base, the construction of membership functions that accurately represent the operational domain, and effective training of the neural component. Furthermore, due to the heterogeneity of the input parameters – train mass, track gradient and curvature, and section length – additional challenges arise in harmonizing scales, preventing overfitting, and ensuring adequate interpretability.

In this context, the application of Fuzzy C-Means (FCM) clustering provides a systematic approach for deriving the initial fuzzy rule structure directly from operational data. When combined with hybrid optimization techniques – such as backpropagation for consequent parameters and stochastic gradient descent for membership-function tuning. This makes it possible to develop a controller that is both adaptive and data-driven.

Modern diesel-generator units used in railway transport operate under conditions of high variability in operational factors, such as changes in track profile, train mass, and section length. These conditions necessitate dynamic adaptation of control actions to ensure stable operation of the power unit, reduce fuel consumption, and enhance overall efficiency.

Traditional control systems are unable to respond promptly to complex variations in multifactor loads, which limits their adaptability and effectiveness. To address this issue, it is reasonable to employ neuro-fuzzy control systems that combine expert rules with machine-learning capabilities. However, constructing an optimal model of such systems requires determining the structure of the fuzzy knowledge base, designing membership functions, and training the neural component while accounting for operating conditions.

Therefore, the study of methods for constructing and training a neuro-fuzzy control system for a diesel-generator unit based on FCM clustering and combined optimization algorithms is of significant relevance.

**Analysis of recent research and problem statement.** Recent scientific developments demonstrate a growing interest in neuro-fuzzy systems and hybrid intelligent controllers for enhancing the adaptability and efficiency of energy and transport systems. ANFIS-based models have been effectively applied to railway power infrastructures, including prediction of reactive power at traction stations and load control under variable operating conditions [1]. In diesel-engine applications, optimisation-enhanced fuzzy PID controllers combined with UKF-based estimation improve speed stability and disturbance rejection [2]. Advanced neuro-fuzzy network architectures, such as fuzzy recurrent stochastic configuration networks, provide high-accuracy modelling with online adaptation for nonlinear industrial processes [3, 4].

A significant body of research focuses on integrating ANFIS controllers into power-system frequency regulation. Their effectiveness has been demonstrated in both classical LFC tasks and renewable-integrated microgrids, particularly when combined with stabilising devices such as STATCOMs [5 – 9]. In hybrid energy systems, ANFIS-based controllers are used for PV maximum power point tracking [10], power-quality enhancement in PV–battery–diesel supply systems [11], and energy-management strategies in AC and islanded microgrids [12, 13]. In wind-energy systems, hybrid ANFIS-PI controllers considerably improve the dynamic performance of DFIG-based turbines [14].

Another direction of research addresses the construction of fuzzy rule bases and membership functions using clustering-based methods. Techniques employing C-means or fuzzy C-means (FCM) clustering help reveal natural structures in experimental data and reduce dependence on expert-defined rules. Such approaches have demonstrated effectiveness in aerospace systems, robotics, and nonlinear industrial control [15, 16, 17].

In the railway domain, intelligent traction-control and decision-support systems increasingly incorporate fuzzy logic and machine-learning techniques to interpret locomotive operating modes and support driver decisions [18, 19]. Furthermore, studies on energy-recovery zones in DC traction emphasise the significant influence of train mass and track profile on power flow, highlighting the need for adaptive, data-driven control strategies [20]. Despite these advancements, most existing works address global traction-system behaviour rather than the localised control of diesel-generator units under rapidly changing operating conditions.

Several important challenges remain unresolved. Current neuro-fuzzy solutions rarely consider the combined influence of train mass, track profile, and section length when forming control actions for diesel-generator units. Many ANFIS-based systems still rely on static membership functions or heuristic tuning methods that limit adaptability. Furthermore, only a few studies incorporate FCM-based derivation of the fuzzy rule structure together with hybrid backpropagation–SGD training of both antecedent and consequent parameters, although such integration is critical for modelling complex nonlinearities in railway operations [8, 9, 15].

Thus, an important scientific gap persists: the need to develop a unified methodology for constructing and training a neuro-fuzzy control system for diesel-generator units that integrates FCM-based structure identification, normalisation of heterogeneous input parameters, and combined optimisation of neuro-fuzzy parameters. Addressing this gap is essential for improving adaptability, fuel efficiency, and dynamic stability of traction power systems operating under variable real-world railway conditions.

**The purpose and tasks of the study.** The purpose of this study is to develop a methodology for constructing and training a neuro-fuzzy control system for a diesel-generator unit that accounts for train mass, track profile, and section length.

The primary task is to determine the structure of the fuzzy system using FCM clustering, to design membership functions based on the cluster centers, and to implement a hybrid-training algorithm for the neural component that combines backpropagation with stochastic gradient descent.

Within the scope of the study, a universal rule base adapted to variable operating conditions is to be developed and its effectiveness evaluated at the simulation stage.

**Materials and methods of research.** The development of the neuro-fuzzy control system for the diesel-generator unit began with the construction of a representative training dataset, in which each element was characterized by a triplet of input parameters: train mass  $M$ , track profile  $P$ , and section length  $L$ . For every combination, the corresponding value of the optimal power-change coefficient  $K_{opt}$  was recorded.

The input variables were normalized to the interval  $[0, 1]$  in accordance with the relation

$$x_{norm} = \frac{x - x_{min}}{x_{max} - x_{min}}, \quad (1)$$

which ensured uniform scaling of the parameters and contributed to the stable performance of the clustering algorithm.

At the first stage, the structure of the fuzzy system was determined using FCM clustering. This algorithm minimizes the functional

$$J = \sum_{i=1}^N \sum_{j=1}^C \mu_{ij}^m \|X_i - V_j\|^2, \quad (2)$$

where  $N$  is the number of training samples;

$C$  is the number of clusters;

$V_j$  is the center of the  $j$ -th cluster;

$\mu_{ij}$  is the degree of membership of the  $i$ -th sample to the  $j$ -th cluster;

$m$  is the fuzzification coefficient.

The membership degrees were updated according to the formula

$$\mu_{ij}^m = \left( \sum_{k=1}^c \left( \frac{\|X_i - V_k\|}{\|X_i - V_j\|} \right)^{\frac{2}{m-1}} \right)^{-1}, \quad (3)$$

whereas the cluster centers were computed using

$$V_j = \frac{\sum_{i=1}^N \mu_{ij}^m X_i}{\sum_{i=1}^N \mu_{ij}^m}. \quad (4)$$

The clustering results determined both the number of rules in the fuzzy system and the shapes of the membership functions of the input variables. Within the  $(M, P, L)$  space, a set of clusters was obtained that forms regions of stable dynamics for the diesel-generator unit.

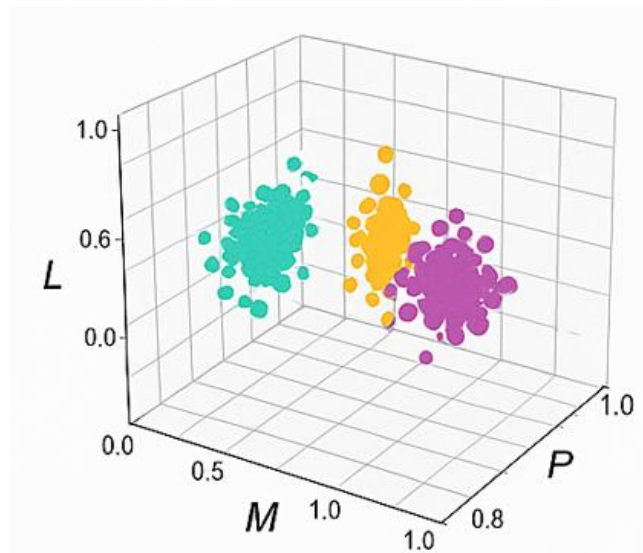

Fig. 1. Spatial distribution of clusters in the  $(M, P, L)$  coordinates

Based on the center  $V_j = (M_j, P_j, L_j)$  of each cluster, membership functions for the fuzzy variables were constructed. Gaussian membership functions of the form were used for the input parameters

$$\mu(x, c, \sigma) = \left[ -\frac{(x-c)^2}{2\sigma^2} \right], \quad (5)$$

where  $c$  is the center of the function, determined by the coordinate of the corresponding cluster;  $\sigma$  is the width, approximated by the root mean square deviation of the set of points with the highest membership degrees.

For each rule of the ANFIS system, a fuzzy antecedent of the form

$$R_j : \text{if } M \in A_j, P \in B_j, L \in C_j, \text{ then } K_{opt} = f_j(M, P, L) \quad (6)$$

was constructed.

At the initial stage, the functions  $f_j$  were assumed to be linear

$$f_j(M, P, L) = a_j M + b_j P + c_j L + d_j, \quad (7)$$

where the coefficients  $a_j$ ,  $b_j$ , and  $c_j$  were subject to subsequent training.

The constructed membership functions provided a smooth representation of the data distribution, ensuring a gradual and stable response of the system to changes in operating conditions.

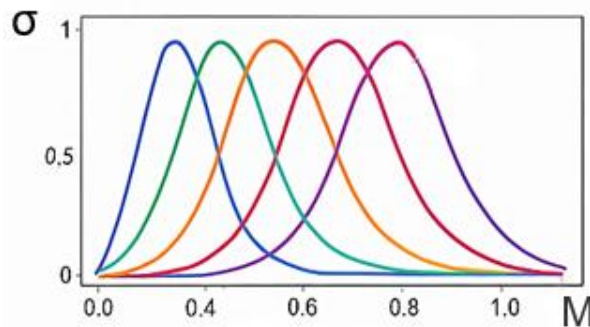

**Fig. 2. Gaussian membership functions for the variable “train mass”**

The figure 2 illustrates the set of membership functions for the input variable *train mass* used in the neuro-fuzzy control system of the diesel-generator unit. Each curve corresponds to a fuzzy term describing a specific interval of mass values (e.g., *very low*, *low*, *medium*, *elevated*, *high*, *very high*).

The values along the horizontal axis are presented in the interval from 0 to 1, which corresponds to the minimum and maximum possible mass values in the input dataset. Such normalization is necessary to ensure the correct operation of both neural and fuzzy learning procedures.

The membership degree  $\sigma$  represents how strongly the current mass value corresponds to a particular fuzzy term. A value of  $\sigma=1$  indicates full membership, whereas  $\sigma=0$  denotes no membership.

The curves overlap so that, for any specific mass value, two or more membership functions are activated simultaneously. This provides smooth transitions between operating modes, eliminates abrupt changes in control actions, and enhances the adaptive power-adjustment capabilities of the diesel-generator unit.

These functions have Gaussian or near-Gaussian shapes, allowing the system to respond gently to changes in mass and improving the learning performance of the ANFIS-type structure.

Membership functions determine how the system perceives train mass not as a strict numerical value, but as a linguistic variable. This enables adaptive adjustment of generator power depending on the train weight, supports the formation of rules such as “if the mass is high, increase traction,” and allows mass information to be integrated with other parameters such as track profile and railway-section length.

The construction of membership functions for the input parameters, including train mass, is a fundamental stage in the development of the fuzzy control system, as it is at this level that numerical values are transformed into linguistic terms subsequently used in the inference mechanism. The membership functions shown in the figure represent the distribution of possible states of the *train mass* variable within the normalized range and determine the degree to which each value belongs to a corresponding fuzzy set. This ensures smooth system response to load variations and enables the consideration of intermediate, imprecisely defined operating conditions.

However, an individual membership function represents only a single parameter and does not capture the combined influence of multiple operational factors on the resulting control action. To construct a

complete rule base, it is necessary to extend the analysis space and integrate several input variables within a unified model. For this reason, the next step involved forming a multidimensional representation in which the optimal control coefficient depends simultaneously on the track profile and the train mass.

The three-dimensional plot illustrates the outcome of integrating the membership functions into the inference structure and demonstrates how variations in two key operational parameters affect the optimal control value. In this way, the system transitions from a one-dimensional fuzzy description of a single variable to a generalized decision surface, which serves as the foundation for an adaptive and robust neuro-fuzzy control system for the diesel-generator unit.

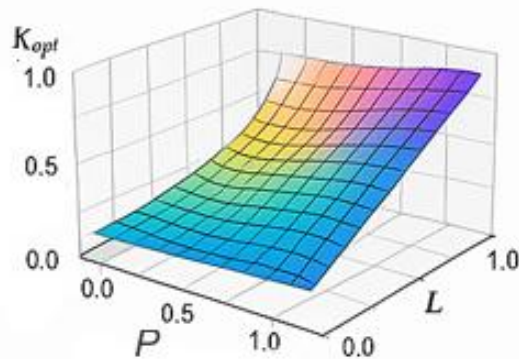

**Fig. 3. The dependence of the optimal control coefficient on track profile and railway section length**

The figure 3 presents a three-dimensional graphical representation of the dependence of the optimal control coefficient  $K_{opt}$  on two key operational parameters – track profile and railway section length. The surface shown in the plot is the result of interpolating the discrete rule base of the neuro-fuzzy system, which makes it possible to transform individual input values into a continuous functional relationship.

The  $P$  axis represents the transition from downhill to uphill conditions. During downhill operation, the diesel-generator unit requires a reduction in power output, which is reflected in lower values of  $K_{opt}$ . Conversely, during uphill operation, the demand for higher traction effort increases, leading to higher values of the control coefficient. The  $L$  axis corresponds to the railway section length, whose influence is integrative: as the length of the segment increases, the controller must compensate for cumulative effects associated with motion resistance and thermal variations in the system.

The surface demonstrates a smooth increase in the control coefficient, from lower values on descents to higher values on ascents and its further growth with increasing section length. This behavior reflects the physical logic of the traction process: the greater the inertial and external forces acting on the rolling stock, the more intensive the energy supply required from the diesel-generator unit.

The resulting surface is a key element in the formation of membership functions and the logical structure of the neuro-fuzzy knowledge base. It provides the ability to implement adaptive control in intermediate operating modes where the conditions are not strictly discrete. Thus, the figure illustrates the generalized relationship governing the variation of the optimal control action depending on the combination of track profile and route length, forming the foundation for designing an intelligent control system for traction power units.

After constructing the fuzzy component, the training of the neural part was carried out using the backpropagation method. The objective of the training process was to minimize the global error

$$E = \frac{1}{2} \sum_{i=1}^N (K_{opt,i} - \hat{K}_{opt,i})^2, \quad (8)$$

where  $\hat{K}_{opt,i}$  is the system response for the  $i$ -th sample.

The partial derivatives of the error function with respect to the parameters of the membership functions were computed according to

$$\frac{\partial E}{\partial c_j} = \sum_{i=1}^N (\hat{K}_{opt,i} - K_{opt,i}) \frac{\partial \hat{K}_{opt,i}}{\partial c_j}; \quad (9)$$

$$\frac{\partial E}{\partial \sigma_j} = \sum_{i=1}^N (\hat{K}_{opt,i} - K_{opt,i}) \frac{\partial \hat{K}_{opt,i}}{\partial \sigma_j}. \quad (10)$$

The coefficients of the linear functions  $a_j$ ,  $b_j$ ,  $c_j$  were updated using the stochastic gradient descent rule

$$\theta^{(t+1)} = \theta^{(t)} - \eta \frac{\partial E}{\partial \theta}, \quad (11)$$

where  $\eta$  is the learning rate.

The combination of FCM-based structural initialization with neural-network training enabled the development of a hybrid model capable of both generalizing the data and improving control accuracy.

The figure presents the structural model of a neural network designed for the automated determination of fuzzy membership function parameters used in the neuro-fuzzy control system of a diesel-generator unit. The depicted architecture represents a multilayer perceptron with differentiable parameters, which ensures adaptive adjustment of the shape and position of membership functions for each input factor, namely: train mass  $M$ , track profile  $P$ , and railway section length  $L$ . This enables the modelling of complex nonlinear relationships between operating conditions and the optimal control actions of the diesel-generator unit.

The first layer of the neural network consists of three inputs, each corresponding to a physical variable. At this stage, the data are provided in a normalized form, which eliminates scale differences between parameters and ensures stable learning. Each input is connected to all neurons of the hidden layer, forming a fully connected structure and enabling the network to process combinations of input factors comprehensively. In this way, the model incorporates the mutual influence of operating parameters, which is critically important for simulating the behavior of traction power systems.

The hidden layer functions as a spatial transformer of the input data, forming a multidimensional representation in which clustering and subsequent identification of fuzzy sets are performed with higher accuracy. The neurons of this layer use nonlinear activation functions, which allow the model to approximate the nonlinear characteristics of diesel-generator operation. Special attention is given to the part of the architecture enclosed in a dashed frame, which represents the subsystem responsible for adjusting membership-function parameters during training. This indicates a modular structure of the network in which the parameters of membership functions constitute a trainable subsystem separate from the main mechanism of generating control actions.

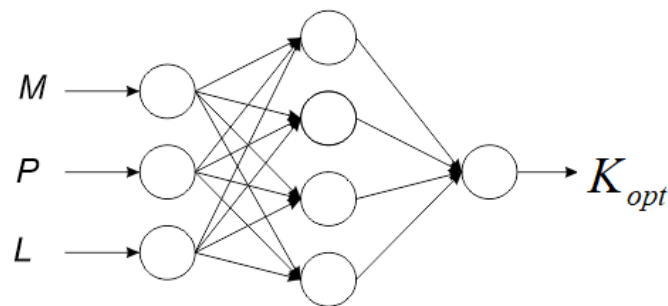

Fig. 4. Simplified neural network architecture

The architecture provides the system with the capability to automatically determine the parameters of fuzzy sets without relying on expert assessments. This aspect is particularly important in the context of controlling diesel-generator units of autonomous rolling stock, where decision-making must account for a wide range of operational states, including variations in train mass, track profile characteristics and segment duration. The neural component enables the formation of a generalized model describing the influence of these parameters and supports learning based on real or synthetic data obtained during simulation or actual operation.

Thus, the presented scheme reflects the adaptation mechanism of the neuro-fuzzy system, in which each parameter of a membership function is the result of an iterative optimisation process. This ensures significantly higher accuracy in forming the rule base and allows the system to efficiently determine optimal control actions for the diesel-generator unit under changing external conditions. Owing to such an architecture, full integration of artificial intelligence methods is achieved in the development of adaptive controllers for transport energy systems.

The training process of the neuro-fuzzy control system involves a staged procedure aimed at ensuring the accurate adaptation of its parameters to a wide spectrum of operating conditions of the diesel-generator unit. At the initial stage, a representative dataset is formed, incorporating input variables such as the train mass, track profile characteristics, and section length, together with corresponding optimal control actions derived from simulation models or empirical measurements. Prior to training, all input variables undergo normalization, which minimizes scale-related distortions and improves the convergence of the learning algorithms.

The system employs a hybrid learning mechanism that combines gradient-based optimization with elements of error backpropagation. Within this framework, the neural component is responsible for adjusting the parameters of membership functions (centers, widths, and slopes) while the fuzzy component ensures the logical consistency of the rule base. During each training iteration, the model evaluates the discrepancy between predicted and target control actions, computes a gradient vector, and updates differentiable parameters to minimize the loss function. This iterative refinement allows the system to capture nonlinear dependencies and interactions among the operational factors.

A significant aspect of the training process is the preservation of interpretability. Although the neural network modifies numerical parameters, the linguistic structure of the fuzzy rules remains intact, ensuring that the resulting control actions can still be interpreted within the framework of expert knowledge. The optimization process continues until the model reaches a stable configuration in which further improvements become marginal. As a result, the trained system is capable of generating adaptive control signals for the diesel-generator unit, providing improved energy efficiency, stable dynamic behavior, and robustness with respect to variations in load and track conditions.

During the training process, the parameters of the membership functions were adapted, which ensured improved fuzzification for intermediate train mass values and complex track profiles. Particular emphasis was placed on adjusting the widths of the Gaussian functions, as variations in  $\sigma_j$  directly influenced the smoothness of the system's response and the breadth of the fuzzy regions. To prevent

overfitting, regularisation coefficients were applied, limiting abrupt parameter shifts and stabilising the learning trajectory.

As a result of the training procedure, a continuous approximation surface was formed, providing a coherent representation of the nonlinear dependence between the input variables and the optimal control coefficient of the diesel-generator unit.

$$\hat{K}_{opt} = F(M, P, L). \quad (12)$$

The practical implementation (fig. 5) of the developed intelligent neuro-fuzzy control system for the diesel-generator unit required the creation of a hardware complex capable of ensuring stable operation of the algorithms under real operating conditions of autonomous rolling stock. The figure shows an experimental prototype of the hardware module, which integrates tools for data acquisition, signal processing, and the generation of control actions. The structural design of the system is implemented in the form of a protected metal enclosure with anti-vibration mounting, which ensures reliable operation of the equipment in harsh transportation environments, including temperature variations, shock loads, and electromagnetic interference.



**Fig. 5. Practical Implementation of the Intelligent Control System for a Diesel-Generator Unit**

The internal structure of the hardware complex is built according to a modular principle. Each module performs a specific function - from preliminary signal filtering to the implementation of adaptive neuro-fuzzy control algorithms. The photograph on the right shows the layout of the internal bus compartment, which contains a series of standardized functional boards. These include analog-to-digital conversion modules, communication units, logic processing controllers, and a high-speed computational module responsible for executing machine-learning algorithms and fuzzy-logic operations.

The key element of the hardware complex is the computational module, which hosts the software environment supporting neuro-fuzzy logic, optimization methods, and machine learning algorithms. Unlike traditional controllers with fixed parameters, the proposed approach enables dynamic reconfiguration of fuzzy-set parameters without the need for manual intervention. As a result, the system can adapt to variations in train mass, track-profile changes, load conditions, and other operational factors that influence the performance of the diesel-generator unit.

During implementation, special attention was given to ensuring the system's reliability and fault tolerance. Each functional module is equipped with redundant power channels and hardware diagnostic mechanisms that provide autonomous fault detection and enable a safe-mode transition in the event of critical deviations.

The resulting neuro-fuzzy model demonstrated the ability to reproduce the optimal operating modes of the diesel-generator unit under various combinations of operational parameters. The validation of the

model was performed by supplying control sets of input values  $M$ ,  $P$ , and  $L$  that were not included in the training dataset. The system provided an accurate estimation of the output variable with minimal deviations, which confirms its generalisation capability.

To assess the effectiveness of the model, the prediction error was analysed

$$\varepsilon = K_{opt} - \hat{K}_{opt}, \quad (13)$$

and its average value did not exceed the established threshold of permissible deviations.

The conducted research resulted in the development of an integrated neuro-fuzzy control model for a diesel-generator unit intended for autonomous rolling stock, demonstrating the system's capability to adapt to a wide spectrum of operational conditions. The proposed architecture combines detailed physical modeling of the power plant with intelligent data-driven mechanisms, enabling dynamic adjustment of control actions in response to variations in train mass, track profile, and route length. Through the implementation of machine-learning-based adaptation of membership-function parameters and the formation of a continuous rule surface, the system achieved a high degree of flexibility and robustness, essential for traction applications characterized by significant nonlinearities and rapidly changing load regimes.

Validation using test inputs not included in the training dataset confirmed the generalization ability of the developed model. The predicted optimal control coefficients exhibited deviations that remained within prescribed tolerance limits, indicating the reliability of the neuro-fuzzy structure in reproducing realistic operating modes of the diesel-generator unit. Analysis of prediction accuracy also revealed that the most challenging scenarios correspond to steep or rapidly changing track profiles, where the system must compensate for abrupt transitions between traction and regenerative modes. Nevertheless, even under such conditions, the controller maintained stable performance due to the optimized configuration of Gaussian membership functions and the use of regularization mechanisms during training.

Overall, the created model forms a foundation for further enhancement of intelligent traction-power control systems. Prospective research directions include deepening the physical detail of subsystems, integrating more advanced neural-network architectures, and extending the optimization framework to multi-criteria formulations that simultaneously account for fuel economy, emission reduction, and dynamic stability. The obtained results demonstrate that hybrid neuro-fuzzy approaches offer substantial potential for improving the efficiency and adaptability of autonomous rolling-stock energy systems.

**Conclusions.** This article presents a methodology for constructing and training a neuro-fuzzy control system for a diesel-generator unit that provides adaptive power regulation depending on train mass, track profile, and section length. The proposed approach combines the FCM clustering method for forming the initial structure of the fuzzy system with a hybrid-training algorithm for the neural component based on backpropagation and stochastic gradient descent. This integration made it possible to determine the optimal number of rules, construct membership functions that reflect the patterns present in the input data, and ensure parameter adjustment during the training process.

The results of the study have shown that the use of fuzzy clustering enables proper structuring of the input space, while the combined training approach improves the accuracy of approximating the relationship between operational parameters and the optimal control action. The resulting model demonstrates the ability to generalize training data and reproduce the optimal operating modes of the power unit across a wide range of operating conditions, confirming its suitability for use in control systems of traction power installations.

Promising directions for further research include improving the algorithms for optimizing fuzzy set parameters, expanding the set of input factors through real-time operational data, integrating the model

into full-scale MATLAB/Simulink simulation systems, and conducting field experiments to validate the performance of the neuro-fuzzy system under real railway operating conditions.

## REFERENCES

- Al-Hadithi, B. M., & Gómez, J. (2025). Fuzzy control and modeling techniques based on multidimensional membership functions defined by fuzzy clustering algorithms. *Applied Sciences*, 15(8), 4479. <https://doi.org/10.3390/app15084479>.
- Chen, T., & Chen, J. C.-Y. (2020). Decentralized fuzzy C-means robust algorithm for continuous systems. *Aircraft Engineering and Aerospace Technology*, 92(2), 222–228.
- Cheng, Y., Zhang, J., Al Shurafa, M., Liu, D., Zhao, Y., Ding, C., & Niu, J. (2025). An improved multiple adaptive neuro fuzzy inference system based on genetic algorithm for energy management system of island microgrid. *Scientific Reports*, 15, 17988. <https://doi.org/10.1038/s41598-025-98665-x>.
- Elborlsy, M. S., Hamad, S. A., El-Sousy, F. F. M., Mostafa, R. M., Keshta, H. E., & Ghalib, M. A. (2025). Neuro-fuzzy controller based adaptive control for enhancing the frequency response of two-area power system. *Heliyon*, 11(4), e42547. <https://doi.org/10.1016/j.heliyon.2025.e42547>.
- Ferdaus, M. M., Anavatti, S. G., Garratt, M. A., & Pratama, M. (2019). Development of C-means clustering based adaptive fuzzy controller for a flapping wing micro air vehicle. *Journal of Artificial Intelligence and Soft Computing Research*, 9(2), 99–109. <https://doi.org/10.2478/jaiscr-2018-0027>.
- Fekry, H. M., ElDesouky, A. A., Kassem, A. M., & Abdelaziz, A. Y. (2020). Power management strategy based on adaptive neuro fuzzy inference system for AC microgrid. *IEEE Access*, 8, 192087–192100. <https://doi.org/10.1109/ACCESS.2020.3032705>.
- Fu, J., Li, J., Li, Y., Dai, X., Sun, J., & Xiao, J. (2025). Research on optimization of diesel engine speed control based on UKF-filtered data and PSO fuzzy PID control. *Processes*, 13(3), 777. <https://doi.org/10.3390/pr13030777>.
- Gorobchenko, O., Holub, H., & Zaika, D. (2024). Theoretical basics of the self-learning system of intelligent locomotive decision support systems. *Archives of Transport*, 71(3), 169–186. <https://doi.org/10.61089/aot2024.gaevsp41>.
- Gorobchenko, O., Zaika, D., Maliuk, S., Arkhypov, O., & Nevedrov, O. (2025). Research of theoretical basis of implementation of intelligent control systems for locomotive traction transmission. *Transport Systems and Technologies*, (45), 145–160. <https://doi.org/10.32703/2617-9040-2025-45-11>.
- Hussein, H., Aloui, A., & AlShammari, B. (2018). ANFIS-based PI controller for maximum power point tracking in PV systems. *International Journal of Advanced and Applied Sciences*, 5(2), 90–96.
- Kumar, K., Das, M., & Karn, A. K. (2024). ANFIS robust control application and analysis for load frequency control with nonlinearity. *Journal of Electrical Systems and Information Technology*, 11, 65. <https://doi.org/10.1186/s43067-024-00175-9>.
- Mantalias, E.-M., Sagias, V. D., Zacharia, P., & Stergiou, C. I. (2025). Neuro-fuzzy model evaluation for enhanced prediction of mechanical properties in AM specimens. *Applied Sciences*, 15(1), 7. <https://doi.org/10.3390/app15010007>.
- Nasim, F., Khatoun, S., Ibraheem, Urooj, S., Shahid, M., Ali, A., & Nasser, N. (2025). Hybrid ANFIS-PI-based optimization for improved power conversion in DFIG wind turbine. *Sustainability*, 17(6), 2454. <https://doi.org/10.3390/su17062454>.
- Oladipo, S., Sun, Y., & Adegoke, S. A. (2025). Application of soft computing techniques to load frequency control system of electric power systems: A brief survey. *Cogent Engineering*, 12(1), 2572297. <https://doi.org/10.1080/23311916.2025.2572297>.
- Panoiu, M., Panoiu, C., & Mezinescu, S. (2023). Modelling and prediction of reactive power at railway stations using adaptive neuro fuzzy inference systems. *Applied Sciences*, 13(1), 212. <https://doi.org/10.3390/app13010212>.
- Rahmani, M., Arabi Nowdeh, S., & colleagues. (2018). Frequency control of islanded microgrids based on fuzzy controller equipped with STATCOM. *Journal of Renewable Energy and Environment*.
- Selvaraju, R. K., & Somaskandan, G. (2017). ACS algorithm tuned ANFIS-based controller for LFC in deregulated environment. *Journal of Applied Research and Technology*, 15(2), 152–166. <https://doi.org/10.1016/j.jart.2017.01.010>.
- Sharma, K., Menaka, C., Saraswat, N., & Kulhar, K. S. (2024). Neuro-fuzzy controllers for power quality improvement of grid connected PV-battery-diesel based hybrid supply system. *E3S Web of Conferences*, 540, 10002. <https://doi.org/10.1051/e3sconf/202454010002>.
- Shynkarenko, V. I., Sablin, O. I., & Ivanov, O. P. (2016). Constructive modelling for zone of recovery energy distribution of DC traction. *Science and Transport Progress*, 5(65), 125–135. <https://doi.org/10.15802/stp2016/84036>.
- Wang, D., & Dang, G. (2024). Fuzzy recurrent stochastic configuration networks for industrial data analytics. *IEEE Transactions on Fuzzy Systems*. Advance online publication. <https://doi.org/10.1109/TFUZZ.2024.3511695>.

**Андрій Залата<sup>1</sup>**

<sup>1</sup>Аспірант, кафедра технічного обслуговування та ремонту рухомого складу, Український державний університет залізничного транспорту, площа Фейєрбаха, 7, Харків, 61050, Україна. ORCID: <https://orcid.org/0009-0003-0557-795X>.

### **Методика навчання нейро-нечіткої системи керування дизель-генераторною установкою в умовах змінних експлуатаційних умов**

**Анотація.** У статті представлено комплексну методику розроблення інтелектуальної нейро-нечіткої системи керування дизель-генераторною установкою автономного рухомого складу. Дослідження спрямоване на підвищення енергоефективності, динамічної стабільності та адаптивності роботи силового агрегату в умовах значної варіативності експлуатаційних параметрів, зокрема маси поїзда, профілю колії та довжини ділянки руху. Запропоновано підхід, що поєднує кластеризацію даних за методом Fuzzy C-Means для формування базової структури нечіткої системи та використання комбінованого алгоритму машинного навчання, який містить зворотне поширення помилки і стохастичний градієнтний спуск. Це забезпечує автоматизоване налаштування параметрів функцій належності та підвищує точність моделювання нелінійних залежностей. У роботі наведено процес формування розширеної дискретної бази правил та побудови інтерпольованої поверхні керувальних дій, яка узагальнює поведінку системи в усьому робочому діапазоні параметрів. Представлено структурну схему нейро-нечіткого контролера, результати навчання та оцінювання моделі на контрольних даних. Показано, що система здатна коректно відтворювати оптимальні режими роботи дизель-генераторної установки з мінімальними відхиленнями та зберігає високі узагальнюючі властивості. Результати дослідження підтверджують ефективність поєднання методів нечіткої логіки і машинного навчання для реалізації адаптивних регуляторів у транспортних енергетичних системах та створюють підґрунтя для подальших розробок у сфері інтелектуального керування автономним рухомим складом.

**Ключові слова:** дизель-генераторна установка, інтелектуальне керування, нейро-нечіткі системи, машинне навчання, автономний рухомий склад.

Дата першого надходження статті до видання 24.10.2025

Дата прийняття до друку статті 25.11.2025

UDC 004.925.4

**Karnatov Serhi<sup>1</sup>\***

<sup>1</sup>Postgraduate student, Automation and Computer-Integrated Transport Technologies Department, National Transport University, M. Omelyanovicha-Pavlenko St., 1, Kyiv, 01010, Ukraine. ORCID: <https://orcid.org/0009-0006-6254-6166>.

\*Corresponding author: [serafim@ukr.net](mailto:serafim@ukr.net).

## **Analysis of PSNR, SSIM, LPIPS metrics in the context of human perception of visual similarity**

*This paper presents a comprehensive comparative analysis of three well-known image quality assessment (IQA) metrics: PSNR, SSIM, and LPIPS. It explores their basic principles, mathematical foundations, advantages, and limitations, particularly as they relate to human visual perception. The evolution of IQA metrics from simple pixel-by-pixel comparisons (PSNR) to structural approaches (SSIM) and, more recently, to learned perceptual metrics (LPIPS) is discussed. A critical analysis of the effectiveness of each metric in assessing various visual distortions, including noise, blur, and compression artifacts, is presented. Inherent issues in human visual perception, such as the role of semantics, texture, color, and visual artifacts, are explored as fundamental causes of discrepancies between objective metric estimates and subjective human judgments. The paper highlights the "unproven effectiveness" of deep features in LPIPS, and discusses its vulnerabilities, such as adversarial attacks and limitations in global semantic understanding. Finally, it outlines directions for future research aimed at developing more robust, interpretable, and perceptually consistent IQA metrics that can better account for the complexity of the human visual system and the evolving demands of modern image processing and generative artificial intelligence technologies.*

**Keywords:** *Image quality assessment, PSNR, SSIM, LPIPS, human perception, visual distortions, generative models, objective metrics, subjective assessment.*

**Introduction.** Image quality and similarity assessment (Image Quality Assessment, IQA) is a fundamental task in modern image processing and computer vision technologies. Objective quantification of visual quality or the degree of similarity between images is critical for a wide range of applications, from data compression and image restoration to the development of artificial intelligence generative models (AIGC), medical imaging, and video surveillance systems. The goal of research in this area is to develop quantitative measures that reliably reflect visual quality and match human perception.

Historically, IQA metrics have undergone significant evolution. Early approaches, such as mean square error (MSE) and peak signal-to-noise ratio (PSNR), were based on simple pixel-by-pixel comparisons. However, it quickly became apparent that such metrics have significant limitations. As noted in [1], "classical pixel-by-pixel metrics, such as Euclidean distance  $l_2$ , are inadequate for evaluating structured outputs such as images because they assume inter-pixel independence." This has led to a fundamental problem: the disconnect between the objective numerical measurements that these metrics provide and the subjective human perception of visual quality and similarity. The human visual system (HVS) processes visual information in a much more complex way, taking into account structural

relationships, semantic context, and other perceptual aspects that are ignored by simple pixel-by-pixel metrics.

This gap has stimulated the development of more sophisticated metrics. The emergence of the structural similarity index (SSIM) was an important step forward, as it takes into account the degradation of structural information, which better correlates with human perception [2]. Later, with the development of deep learning, metrics such as LPIPS (Learned Perceptual Image Patch Similarity), which are trained directly on large datasets of human similarity judgments, attempting to model HVS even more accurately [3, 4]. This evolution reflects a gradual awareness of the complexity of human visual perception and the desire to create tools that more adequately reflect subjective experience.

Accurate IQA metrics are particularly relevant in the context of the rapid development of artificial intelligence generative models (AIGCs) that are capable of creating photorealistic images. Traditional metrics often fail to adequately assess the quality of such images, which may contain subtle but visually significant artifacts or semantic inconsistencies. Metrics that focus on per-pixel or simple structural differences may not capture these nuances. This creates an urgent need for metrics that better align with human perception of fine detail and semantic coherence, which are critical for evaluating AI-generated content [5, 6].

**Analysis of recent research and problem statement.** Research in the field of image quality assessment is an extremely active area in computer vision and signal processing, and numerous works demonstrate both progress and unsolved challenges.

Early work focused on metrics based on signal error, such as PSNR, derived from MSE. They were dominant due to their simplicity of calculation and clear mathematical interpretation. However, as Wang et al. point out in their pioneering work on SSIM [2], "traditional image quality metrics such as MSE and PSNR do not correlate well with human perception of image quality." Research also indicates that "PSNR does not always correlate with perceived visual quality because human perception of images can be affected by factors not reflected in pixel differences." According to Zhang's work and al. [7], PSNR "even gives the same value for all very different degradations ". This is clear evidence of the inadequacy of PSNR for perceptual assessment.

The answer to these limitations was the introduction of structural metrics. Wang and al. [2] proposed SSIM based on the idea that HVS is highly adapted to extract structural information. SSIM showed a significantly better correlation with human judgments compared to PSNR, which was confirmed in many subsequent studies. However, SSIM also has its limitations. In the work "Image quality assessment: From error visibility this structural similarity" [2, 8] shows that "a small spatial shift of an image can mean that it has a very low SSIM score, although the subjective image quality is the same as the reference". SSIM can also be insensitive to hue changes [9, 10]. Research on medical image quality assessment [11] indicates that SSIM "cannot identify a hole (local information loss)". The development of multi-scale SSIM (MS-SSIM) [12] was an attempt to overcome the limitations of single-scale analysis by recognizing the multi-scale nature of LSI.

With the advent of the deep learning era, a new class of perceptual metrics has emerged. LPIPS, proposed by Zhang and al. [4], is a prime example of this direction. This metric uses features extracted from pre-trained CNNs and is trained on large datasets of human perceptual judgments (e.g., the BAPPS dataset containing hundreds of thousands of comparisons [4]). Original work by Zhang and al. showed that deep features significantly outperform classical metrics in correlation with human perception. This is also confirmed in [13, 14], where it is noted that "CNNs trained on ImageNet learn a hierarchy of features from simple (contours, textures) to complex (parts of objects, objects), which is somewhat analogous to hierarchical processing in HVS". Despite this, LPIPS is not an ideal metric. As noted in [15], LPIPS is vulnerable to adversarial attacks, where small, visually imperceptible changes to a human result in a significant change in the LPIPS estimate. In addition, its patch-oriented analysis may not take into account global semantic coherence [16]. Problems with estimating massive local information loss (e.g., a "hole" in an MRI) have also been noted for LPIPS [11].

The relevance of the problem also increases in the context of assessing the quality of images generated by artificial intelligence. Traditional metrics are often unable to adequately assess the quality

of such images, which may contain subtle but visually significant artifacts or semantic inconsistencies [16]. This creates an urgent need for metrics that better match human perception of fine details and semantic coherence.

Thus, despite significant progress, the development of IQA metrics that fully reflect the complexity of human visual perception remains an open problem. Each of the considered metrics – PSNR, SSIM, LPIPS – has its own strengths and weaknesses, and none of them can be a universal "gold standard" for all types of distortions and applications. There is a need for a deep comparative analysis of these metrics to clearly outline the scenarios of their effective and ineffective use.

**Research goals and objectives.** The main goal of the research is to conduct a comparative analysis of the PSNR, SSIM, and LPIPS metrics in order to identify their effectiveness in reflecting human visual perception of image similarity and quality, as well as to determine their advantages, disadvantages, and specifics of application in the context of various types of visual distortions.

**Materials and methods of research.** Classical metrics for assessing image quality PSNR (Peak Signal-to-Noise Ratio) is one of the oldest and simplest metrics used to evaluate image quality, especially in the context of lossy compression.

Principle of operation and formula: PSNR measures the ratio between the maximum possible signal (image) power and the power of distorting noise, which affects the accuracy of its representation. PSNR is based on the mean square error (MSE), which is calculated as the average square of the differences in pixel intensities between the original ( $I$ ) and distorted ( $K$ ) images of size  $M \times N$

$$MSE = \frac{1}{M \times N} \cdot \sum_{i=0}^{M-1} \sum_{j=0}^{N-1} [I(i, j) - K(i, j)]^2. \quad (1)$$

After calculating the MSE, the PSNR is calculated using the formula:

$$PSNR = 10 \cdot \log_{10} \left( \frac{MAX_I^2}{MSE} \right), \quad (2)$$

where  $MAX_I$  is the maximum possible pixel value of the image (for example, 255 for an 8-bit image); PSNR is measured in decibels (dB), and higher values generally indicate better quality of the reconstructed image. Typical PSNR values for lossy image and video compression range from 30 to 50 dB for 8-bit data.

**Advantages:** The main advantages of PSNR are its mathematical simplicity, ease of calculation, and clear physical meaning, especially for estimating additive white Gaussian noise. Due to these characteristics, PSNR is widely used as a baseline performance indicator for lossy compression algorithms and other image processing methods.

**Disadvantages:** Despite its widespread use, PSNR has a number of significant drawbacks that limit its applicability for adequate assessment of perceptual quality:

- Low correlation with human perception: PSNR often correlates poorly with how humans perceive image quality. The metric treats all per-pixel errors equally, regardless of their visual impact, structural context, or location in the image.
- Insensitivity to structural distortions: PSNR does not take into account structural information in the image. Therefore, it is insensitive to distortions such as blurring, blocking, edge displacement, or other artifacts that destroy the structure but may have a small mean square error.
- Misleading results: Two images with the same PSNR value can have drastically different visual quality to the human eye [7].
- Ignoring masking effects of LSR: PSNR does not take into account such important aspects of human vision as masking effects, when distortions in some areas of the image (for example, textured or high-contrast) are less noticeable than in others.

The mathematical simplicity and ease of calculation of PSNR, which have contributed to its widespread use, are at the same time its fundamental disadvantage for perceptual assessment.

SSIM (Structural Similarity Index Measure). The structural similarity index (SSIM) has been proposed as an alternative to PSNR that better matches human perception of image quality because it estimates the degradation of structural information [2].

Working principle and formula: The basic principle of SSIM is that the human visual system is highly adapted to extract structural information from a scene. Therefore, a metric that measures the preservation of structure should correlate better with subjective quality assessment. SSIM is a perception-based model that considers image degradation as a perceived change in structural information, unlike MSE or PSNR. SSIM is computed locally for image windows and compares three key features: luminance, contrast, and structure.

The general SSIM formula for two windows  $x$  and  $y$  has the form [2]:

$$SSIM(x, y) = \left[ l(x, y)^\alpha \cdot c(x, y)^\beta \cdot s(x, y)^\gamma \right], \quad (3)$$

where  $l(x, y)$ ,  $c(x, y)$  and  $s(x, y)$  are the brightness, contrast and structure comparison components, respectively;

$\alpha, \beta, \gamma > 0$  are parameters that determine the relative importance of each component (usually set to 1).

The SSIM value ranges from -1 to 1 (or 0 to 1 in some implementations), where 1 means perfect similarity. The overall score for the entire image is usually obtained as the mean value of the local SSIMs (MSSIM).

Advantages:

- Better correlation with HVS: SSIM correlates significantly better with human perception of image quality compared to PSNR because it takes into account structural changes that are important for HVS [2].
- Sensitivity to important aspects: The metric is sensitive to changes in brightness, contrast, and structural details.
- Local Similarity Map: SSIM allows you to generate a local similarity map (SSIM map), which shows how quality varies across an image, providing more information than a single global value.
- Consideration of masking effects: SSIM implicitly takes into account the masking effects of brightness and contrast through the way its components are calculated.

Disadvantages:

- Imperfect LSI modeling: SSIM still does not fully model all aspects of human visual perception. It may not perform well with certain types of distortions, such as strong blurring, significant color shifts, or small spatial shifts [2].
- Sensitivity to geometric transformations: SSIM is sensitive to rotations and scaling, although there are modifications such as CW-SSIM that attempt to address this issue.
- Single-scale limitation: Classical SSIM analyzes images at a single scale, which is a limitation because the LMS perceives information at different levels of detail. This drawback is partially addressed in multi-scale SSIM (MS-SSIM) [12].
- Problems with medical images: SSIM may underestimate distortion near sharp edges or have instability in low-dispersion regions, which is especially relevant for medical images [11].
- Insufficient consideration of semantics: SSIM, while taking structure into account, is still a relatively low-level metric and does not analyze the semantic content of the image.

SSIM is an important step towards creating more perceptually relevant metrics. However, its components (brightness, contrast, structure) are still relatively low-level statistical characteristics of pixel intensities in a local area, not capturing deep semantic aspects or the more complex cognitive processes of human perception.

Modern learning-based metrics: LPIPS. With the advent of deep learning, a new class of image quality and similarity metrics has emerged that are trained directly on human perceptual judgment data. One of the most famous such metrics is LPIPS (Learned Perceptual Image Patch Similarity).

LPIPS (Learned Perceptual Image Patch Similarity). How it works: LPIPS computes the perceptual similarity between two images by measuring the distance between their representations in a deep feature space extracted using convolutional neural networks (CNNs). These CNNs (e.g., AlexNet, VGG, SqueezeNet) are typically pre-trained on large datasets for high-level tasks such as image classification (e.g., ImageNet), or they can be specifically trained or fine-tuned on datasets containing human ratings of perceptual similarity of images, such as BAPPS (Berkeley-Adobe Perceptual Patch Similarity) dataset [4].

The LPIPS calculation process is as follows:

- Two images (reference and distorted) are passed through the selected pre-trained CNN.
- Activation maps (features) are extracted from several layers of the network. Different layers correspond to different levels of abstraction of visual information, from low-level textures to more complex structural elements.
- These activation maps for each image are processed (e.g., normalized across channels).
- The distance (usually the weighted Euclidean distance  $l_2$ ) between the corresponding activation maps for the two images is calculated.
- These distances are averaged across spatial dimensions and across layers (with specific weights for each layer, which can also be learned) to produce a single LPIPS value. A low LPIPS value indicates high perceptual similarity between images.

Advantages:

- High correlation with human perception: LPIPS shows significantly better correlation with human judgments of image similarity compared to traditional metrics such as PSNR and SSIM [4].
- Ability to capture complex visual distinctions: Through the use of deep features, LPIPS can distinguish subtle textural and structural nuances.
- The "unreasonable efficiency" of deep features: Studies have shown that even features from networks trained on high-level tasks turn out to be surprisingly effective at estimating low-level perceptual similarity.

Limitation:

- Vulnerability to adversarial attacks: One of the most significant shortcomings of LPIPS is its vulnerability to adversarial attacks. Small changes, visually imperceptible to a human, can lead to a significant change in the LPIPS estimate, which does not correspond to human perception [15].
- Patch-oriented analysis and global semantics: LPIPS computes similarity based on the comparison of individual image patches. While this allows for the analysis of local details and textures, this approach may not fully account for global semantic coherence or long-term spatial dependencies across the entire image [16].
- Dependence on the architecture and training of the underlying CNN: The quality of the features used by LPIPS depends on the specific CNN architecture and the data on which it was trained.
- Computational complexity: Compared to PSNR and SSIM, LPIPS can be a more resource-intensive metric.
- Interpretability: Like many deep learning models, LPIPS can be less interpretable ("black box") compared to metrics like SSIM.
- Specific types of distortion: LPIPS may have difficulty estimating images with very low texture or homogeneous regions. Problems with variations between stereo pairs have also been noted.

Despite these limitations, LPIPS has become an important tool in image quality assessment, especially for generative models and image restoration tasks where perceptual quality is a priority [17].

**The problem of human perception of image similarity.** Understanding how humans perceive visual similarity is key to developing and evaluating the effectiveness of objective image quality metrics. The human visual system (HVS) is an extremely complex mechanism whose work goes far beyond the simple registration of light intensities.

Human visual perception is a multi-step process that begins with the detection of photons of light by the retina and ends with the formation of a conscious image and its interpretation in the brain. It is important to emphasize that what we see is not a simple translation of the retinal stimulus; the brain

actively processes, filters, and supplements the information received. This active interpretation is one of the main reasons for the discrepancies between objective metrics and subjective assessment.

Early theories of perception, such as Hermann von Helmholtz's theory of unconscious inference, argued that the brain makes assumptions and inferences based on incomplete sensory data and prior experience. For example, we unconsciously assume that light falls from above, faces are usually perceived upright, and nearer objects can obscure more distant ones. These built-in assumptions help us quickly interpret a visual scene, but they can also lead to visual illusions.

Gestalt theory has provided a number of important principles for organizing visual elements into coherent images or "gestalts" [18]. These principles include:

- Proximity: Objects located nearby are perceived as a group.
- Similarity: Elements that are similar in shape, color, size, or other characteristics are grouped together.
- Closure: The HVS tends to "complete" the missing parts of a figure in order to perceive it as complete.
- Symmetry: Symmetrical objects are more easily perceived as a single whole.
- Common destiny: Elements moving in the same direction are perceived as connected.
- Continuity (or good continuation): The HVS prefers the perception of smooth, continuous lines and contours.
- Good Gestalt (law of pregnancy): The simplest, most regular, and most stable shapes are perceived.
- Past Experience: Prior knowledge and experience influence how we interpret visual stimuli.

These principles show that the LNS actively structures visual input, rather than passively registering it. David Marr proposed to consider vision as a feature processing process that involves extracting basic components of a scene, such as edges, corners, regions, and textures, forming the so-called "primary sketch" [19]. This processing is hierarchical: from low-level features (color, brightness, orientation of local contours), the system proceeds to the analysis of medium-level characteristics (texture, grouping of elements, spatial arrangement of the scene) and, finally, to high-level interpretation (recognition of objects, understanding their relationships and the semantic content of the scene).

The LMS is also a highly adaptive system. Its sensitivity to different spatial frequencies (detail), contour orientations, contrast levels, and motion dynamics is not constant, but varies depending on the viewing conditions and the characteristics of the stimulus itself. Masking effects play an important role, when the presence of some visual elements (for example, complex texture or high contrast) can reduce the visibility of other elements or distortions in the same image area. In addition, visual attention (saliency) directs processing resources to the most significant or informative parts of the scene, which means that not all parts of the image are perceived with the same detail and importance.

The complexity and multifactorial nature of LPS is the root cause of the inadequacy of simple metrics. Objective metrics often focus on one or a few aspects (e.g., pixel-wise difference for PSNR, local structure for SSIM), while humans integrate a vast amount of information at different levels. PSNR ignores virtually all of the listed aspects of LPS. SSIM partially accounts for structure and some masking effects, but not semantics or global organization. LPIPS, trained on human data, tries to implicitly capture this complex processing, but is still limited by its architecture and training data.

Despite continuous progress in the development of objective image quality metrics, discrepancies between their estimates and human subjective perception remain a significant problem. These discrepancies arise due to the fundamental complexity of HVS and its ability to take into account context, semantics, and previous experience, which are difficult to formalize in the form of mathematical models.

Examples of counterintuitive metric results:

- PSNR can show the same values for images with completely different types of distortion (e.g., blur, noise, compression artifacts), which are visually perceived in completely different ways [7].
- SSIM, although it correlates better with HVS, also has its weaknesses. For example, it may give a low score to images with small spatial shifts that appear almost identical to humans. Conversely, SSIM

may show high similarity for images with significant color changes, if their structure is preserved. SSIM may also have problems with the assessment of strongly blurred images or images with massive local information loss [11].

- LPIPS, despite its perceptual validity, is also not without its drawbacks. Its patch-oriented analysis can lead to situations where patches are locally similar, but globally the image is incoherent or semantically incorrect [16]. The most well-known problem with LPIPS is its vulnerability to adversarial attacks [15].

These discrepancies often arise because metrics “focus on the wrong thing.” Human perception is flexible and can emphasize different aspects depending on the context, task, and importance of the information.

Comparing the performance of PSNR, SSIM, and LPIPS metrics is key to understanding their strengths and weaknesses in different practical scenarios. Their behavior varies significantly depending on the type of visual distortion present in the image.

These discrepancies often arise because metrics have a fixed “focus.” Human perception, in contrast, is flexible and adapts to the context and task.

To quantitatively assess the correspondence of objective metrics to human perception, correlation coefficients with subjective estimates, such as MOS and DMOS, obtained as a result of psychophysical experiments are used [20].

A general trend observed in numerous studies on various databases (e.g. LIVE, TID2013, CSIQ, KADID-10k):

- LPIPS typically exhibits the highest correlation (measured, for example, by Spearman's rank correlation coefficient (SRCC) or Pearson's linear correlation coefficient (PLCC)) with MOS/DMOS, outperforming SSIM and PSNR [4].

- SSIM usually shows better correlation with human judgment than PSNR [2].

- PSNR often has the lowest correlation with human quality ratings.

**Metric quality assessment on compression samples.** To compare the evaluation of different metrics, we will take an image of 512x512 pixels and compress it using the fractal method (FIC). The sample for the study is the portrait of Isaac Newton, posted on Wikipedia. The image was compressed using the fractal method with the rank block size: 256, 128, 64, 32, 16, 8, 4. Accordingly, the quality of the compressed image improved with decreasing block size. Figure 1 shows a collage of compressed images and the original. The results of calculating the PSNR, SSIM, LPIPS metrics are given in Table 1.

*Table 1. Image compression quality metrics using the FIC method*

Rank block size (pix)	PSNR (dB)	SSIM	LPIPS
256	16.9385	0.4605	0.9095
128	20.0715	0.4985	0.7824
64	23.2162	0.5300	0.6997
32	26.5780	0.5849	0.6234
16	28.5952	0.6581	0.4810
8	30.5655	0.7714	0.2693
4	35.2494	0.9326	0.0642

Given the significant difference in the concept of metrics, they should be normalized for comparison. The range of PSNR values can be quite large, but we normalize the indicator to a value of 40 as the maximum, often, with such a quality of the resulting image, a person cannot distinguish the processed image from the original. The resulting indicator will take values from 0 to 1 (the higher, the better). SSIM takes values from 0 to 1, the higher, the better. We leave it unchanged. LPIPS takes values from 0 - 1, but the lower the better. Therefore, for comparison, the inverse value to 1 should be used. Comparative values are presented in the form of diagram 1.

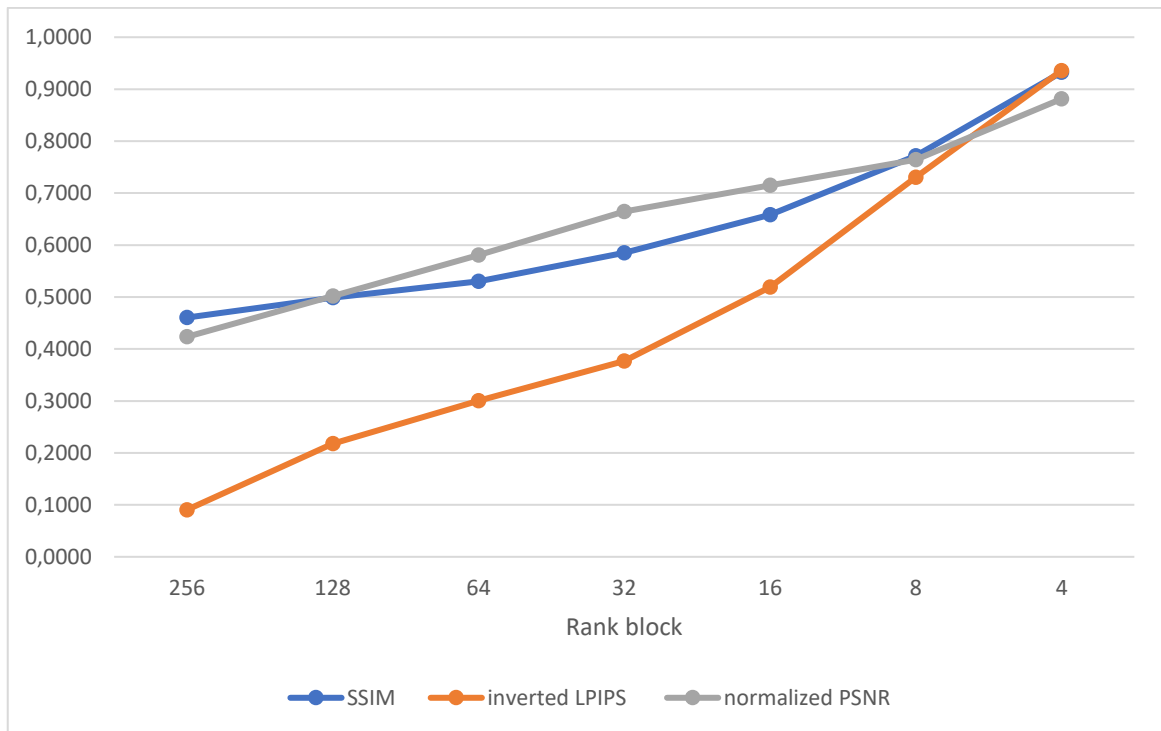

Diagram 1. Comparison of SSIM, inverted LPIPS, normalized PSNR

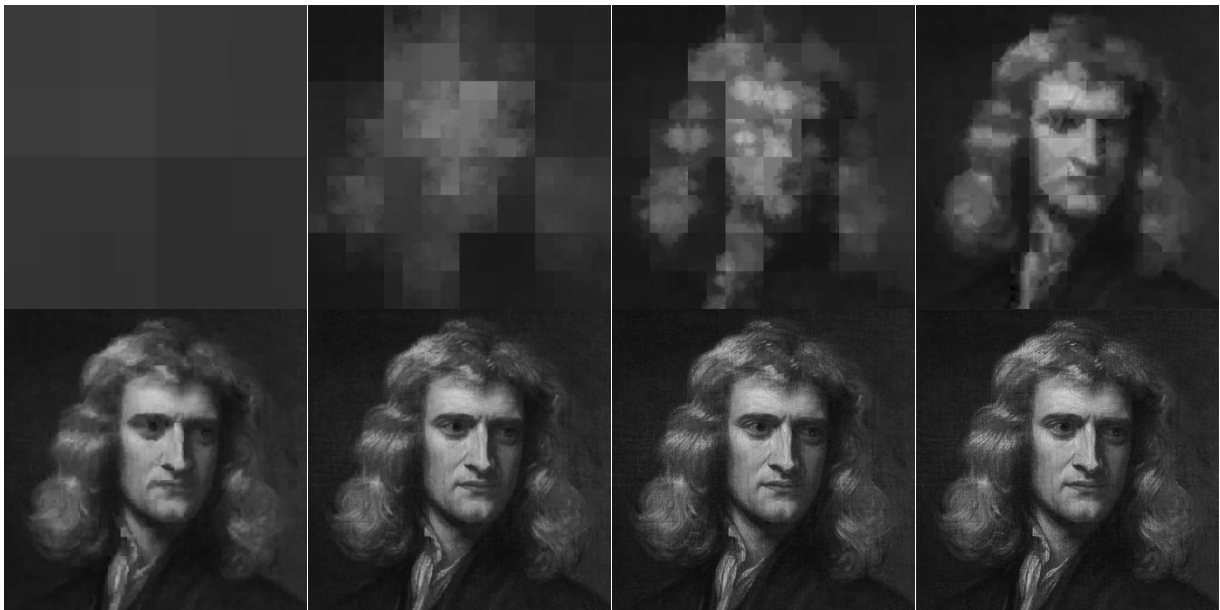

Fig. 1. Images compressed by FIC with rank blocks: 256, 128, 64, 32, 16, 8, 4 and original

As can be seen from Diagram 1 for PSNR metrics, even SSIM gray square is very similar to "Newton". The gray background, which occupies most of the original image, creates conditions for a high estimate of the similarity of PSNR and SSIM. PSNR steadily increases with decreasing block size (from 16.9 dB to 35.2 dB). The graph (gray line "normalized PSNR") shows an almost linear increase. This uniform increase does not reflect the real "jump" in quality that we see between blocks 32 and 16. PSNR equally "evaluates" the transition from illegible squares to a barely recognizable face. SSIM also increases with decreasing block size (from 0.46 to 0.93). Its curve (blue line) is slightly steeper than that of PSNR, which better reflects the improvement in quality in the last stages. Although SSIM is better

than PSNR, it still does not fully correlate with human perception, especially at low-quality stages. The "inverted LPIPS" curve grows slowly in the initial stages (when the image is indistinct) and goes up very sharply in the range from 32 to 4. This corresponds perfectly to visual analysis: the metric captures a slight improvement when the image remains "blocky" and gives a high score precisely at those steps where the image becomes recognizable and clear. LPIPS is noticeably better at assessing quality, which is confirmed by visual comparison of drawings.

**Conclusions:** Analysis of PSNR, SSIM, and LPIPS metrics revealed significant differences in their operating principles, advantages, disadvantages, and most importantly, in their ability to reflect human perceptions of image similarity and quality.

- PSNR, as the simplest of the considered metrics, is based on the per-pixel root mean square error. Its advantages are ease of calculation and clear interpretation for certain types of additive noise. However, a fundamental disadvantage of PSNR is its low correlation with human visual perception. It ignores structural information, semantic content, and complex LSR mechanisms such as masking effects. This leads to situations where images with the same PSNR can have radically different visual quality, as well as the inability to adequately assess the impact of many common distortions such as blurring or compression artifacts.

- SSIM is a significant step forward because it was developed taking into account that the LMS is highly adapted to extract structural information. By comparing the brightness, contrast, and structure of local image regions, SSIM shows a much better correlation with human judgment than PSNR. It is more sensitive to structural distortions that are visually significant. However, SSIM still has limitations: it can be insensitive to significant color changes if the structure is preserved, it does not cope well with strong blurring or small spatial shifts, and it does not sufficiently take into account global semantic information.

- LPIPS represents a modern approach based on deep learning. Using features extracted from pre-trained convolutional neural networks and training directly on large datasets of human perceptual judgments, LPIPS achieves the highest correlation with human perception among the considered metrics. It is able to capture more complex visual differences, including textural and structural nuances. Unlike the mathematical models PSNR and SSIM, LPIPS is "trained" to understand which changes in the image are important to a person. It ignores minor shifts or noise that the human eye does not pay attention to, but which greatly degrade the PSNR/SSIM indicators. LPIPS is able to better assess the preservation of objects and textures. In this example, it correctly determines that a significant object (face) appears at the "Block 16" stage, and "rewards" this with a significant improvement in the assessment. This metric is particularly useful for evaluating the performance of generative neural networks (GANs) and other deep learning algorithms, where the goal is to produce a realistic, rather than pixel-precise, image. However, LPIPS is not a panacea. Its main drawbacks include vulnerability to adversarial attacks, potential problems with estimating global semantic consistency through patch-oriented analysis, dependence on the architecture and training of the underlying CNN, and higher computational complexity.

The problem of human perception of similarity and its reflection in metrics lies in the fundamental complexity of HVS. Human perception is an active, interpretive process that takes into account a huge number of factors: from low-level features (color, brightness) through medium-level (texture, Gestalt principles) to high-level (semantics, context, previous experience). None of the existing objective metrics is able to fully capture this complexity.

Thus, the experimental results clearly demonstrate that for the evaluation of compression quality oriented to the end user (human), LPIPS is a much more informative and reliable metric than the classical PSNR and SSIM. LPIPS is the most perceptually relevant metric of the three considered for a wide range of distortions, followed by SSIM, and PSNR demonstrates the worst correspondence to human perception. However, even LPIPS can give counterintuitive results in certain scenarios, especially when assessing global semantic coherence or in the presence of atypical artifacts not represented in the training sample.

Future research directions will likely focus on developing even more sophisticated metrics that:

- Better integrate global semantic understanding (perhaps using transformative architectures).

- Are more robust to adversarial attacks and unknown types of distortions.
- They ensure better interpretability of their assessments.
- Take into account the specifics of the task and content (e.g. for medical imaging, AIGC).

In conclusion, while objective metrics are indispensable tools in image processing, it is important to remember their limitations and to complement their analysis with subjective human evaluation whenever possible, especially in critical applications. Understanding the principles of LMS operation and continuously improving metrics will bring us closer to creating tools that truly reflect the human vision of quality.

## REFERENCES

1. Johnson, J., Alahi, A., & Fei-Fei, L. (2016, September). Perceptual losses for real-time style transfer and super-resolution. In *European conference on computer vision* (pp. 694-711). Cham: Springer International Publishing. [https://doi.org/10.1007/978-3-319-46475-6\\_43](https://doi.org/10.1007/978-3-319-46475-6_43).
2. Wang, Z., Bovik, A. C., Sheikh, H. R., & Simoncelli, E. P. (2004). Image quality assessment: from error visibility to structural similarity. *IEEE transactions on image processing*, 13(4), 600-612. <https://doi.org/10.1109/TIP.2003.819861>.
3. Breger, A., Biguri, A., Landman, M. S., Selby, I., Amberg, N., Brunner, E., ... & Schönlieb, C. B. (2025). A study of why we need to reassess full reference image quality assessment with medical images. *Journal of Imaging Informatics in Medicine*, 1-26. <https://doi.org/10.1007/s10278-025-01462-1>
4. Zhang, R., Isola, P., Efros, A. A., Shechtman, E., & Wang, O. (2018). The unreasonable effectiveness of deep features as a perceptual metric. In *Proceedings of the IEEE conference on computer vision and pattern recognition* (pp. 586-595). <https://arxiv.org/abs/1801.03924>.
5. Arabboev, M., Begmatov, S., Rikhsivoev, M., Nosirov, K., & Saydiakbarov, S. (2024). A comprehensive review of image super-resolution metrics: classical and AI-based approaches. *Acta IMEKO*, 13(1), 1-8. <https://doi.org/10.21014/actaimeko.v13i1.1679>.
6. Gertsy, O. (2024). Research on graphic data formats for compact representation and comparison of images. *Transport systems and technologies*, (43), 173-187. <https://doi.org/10.32703/2617-9059-2024-43-14>.
7. Zhang, L., Zhang, L., Mou, X., & Zhang, D. (2011). FSIM: A feature similarity index for image quality assessment. *IEEE transactions on Image Processing*, 20(8), 2378-2386. <https://doi.org/10.1109/TIP.2011.2109730>.
8. Shrestha, B. (2005). Evaluation of JPEG2000 for lossless medical image compression. *Mississippi State University Libraries*. [https://www.gri.msstate.edu/publications/docs/2005/03/4328BijayShrestha\\_2005.pdf](https://www.gri.msstate.edu/publications/docs/2005/03/4328BijayShrestha_2005.pdf).
9. Russ, J. C. (2006). *The image processing handbook*. CRC press.
10. Gonzalez, R.C., & Woods, R.E. (2017). *Digital Image Processing*. Pearson, New York, 4 editions.
11. Singh, G.K., Agarwal, A., & Reddy, N.V. (2023). Comparison of PSNR, SSIM, and LPIPS in medical imaging. In *2023 IEEE 12th International Conference on Computing Communication and Networking Technologies (ICCCNT)* (pp. 1-6). [https://www.researchgate.net/figure/LPIPS-SSIM-and-PSNR-Metrics-Comparison-This-table-evaluates-the-quality-of-generated\\_tbl2\\_382080667](https://www.researchgate.net/figure/LPIPS-SSIM-and-PSNR-Metrics-Comparison-This-table-evaluates-the-quality-of-generated_tbl2_382080667).
12. Wang, Z., Simoncelli, E. P., & Bovik, A. C. (2003, November). Multiscale structural similarity for image quality assessment. In *The thirty-seventh asilomar conference on signals, systems & computers, 2003* (Vol. 2, pp. 1398-1402). IEEE. <https://doi.org/10.1109/ACSSC.2003.1292216>.
13. Kuzovkin, I., Vicente, R., Petton, M., Lachaux, J. P., Baciú, M., Kahane, P., ... & Aru, J. (2018). Activations of deep convolutional neural networks are aligned with gamma band activity of human visual cortex. *Communications biology*, 1(1), 107. <https://doi.org/10.1038/s42003-018-0110-y>.
14. Zhang, K., Liang, J., Van Gool, L., & Timofte, R. (2021). Designing a practical degradation model for deep blind image super-resolution. In *Proceedings of the IEEE/CVF international conference on computer vision* (pp. 4791-4800). <https://doi.org/10.48550/arXiv.2103.14006>.
15. Zhai, G., & Min, X. (2020). Perceptual image quality assessment: a survey. *Science China Information Sciences*, 63(11), 211301. <https://doi.org/10.1007/s11432-019-2757-1>.
16. Gu, S., Bao, J., Chen, D., & Wen, F. (2020, August). Giqa: Generated image quality assessment. In *European conference on computer vision* (pp. 369-385). Cham: Springer International Publishing. [https://doi.org/10.1007/978-3-030-58621-8\\_22](https://doi.org/10.1007/978-3-030-58621-8_22).
17. Shoshan, A., Gandselman, Yo., Bagon, S., & Dekel, T. (2024). R-LPIPS: An Adversarially Robust Perceptual Similarity Metric. *Scientific Reports*. <https://doi.org/10.48550/arXiv.2307.15157>.
18. Koffka, K. (1935). *Principles of Gestalt Psychology*. Harcourt, Brace & Co.
19. Marr, D. (1982). *Vision: A computational investigation into the human representation and processing of visual information*. WH Freeman and Company.
20. International Telecommunication Union. (2019). *Methodology for the subjective assessment of the quality of television pictures* (Recommendation BT.500-14). [https://www.itu.int/rec/R-REC-BT.500-14-201910-S/en\\_russ](https://www.itu.int/rec/R-REC-BT.500-14-201910-S/en_russ)

**Карнатов Сергій<sup>1</sup>**

<sup>1</sup>Аспірант, Кафедра Автоматизація та комп'ютерно-інтегровані технології транспорту, Національний транспортний університет, вул. Михайла Омеляновича-Павленка, 2, 01010, м. Київ, Україна. ORCID: <https://orcid.org/0009-0006-6254-6166>.

### **Аналіз метрик PSNR, SSIM, LPIPS у контексті людського сприйняття візуальної подібності.**

**Анотація.** Ця стаття пропонує комплексний порівняльний аналіз трьох відомих метрик оцінки якості зображення (IQA): PSNR, SSIM та LPIPS. У ній досліджуються їхні основні принципи, математичні основи, переваги та обмеження, зокрема, що стосуються їхньої кореляції зі зоровим сприйняттям людини. Обговорюється еволюція метрик IQA від простих піксельних порівнянь (PSNR) до структурних підходів (SSIM) та, нещодавно, до метрик вивченого сприйняття (LPIPS). Представлено критичний аналіз ефективності кожної метрики в оцінці різних візуальних спотворень, включаючи шум, розмиття та артефакти стиснення. Притаманні людському зоровому сприйняттю проблеми, такі як роль семантики, текстури, кольору та візуальних артефактів, досліджуються як фундаментальні причини розбіжностей між об'єктивними метричними оцінками та суб'єктивними людськими судженнями. У статті висвітлюється «необґрунтована ефективність» глибоких ознак у LPIPS, а також розглядаються його вразливості, такі як атаки з боку суперників та обмеження в глобальному семантичному розумінні. Зрештою, у ньому окреслено напрямки майбутніх досліджень, спрямованих на розробку більш надійних, інтерпретованих та перцептивно узгоджених метрик IQA, які можуть краще враховувати складність зорової системи людини та мінливі вимоги сучасних технологій обробки зображень та генеративного штучного інтелекту.

**Ключові слова:** Оцінка якості зображень, PSNR, SSIM, LPIPS, людське сприйняття, візуальні спотворення, генеративні моделі, об'єктивні метрики, суб'єктивна оцінка.

Дата першого надходження статті до видання 14.09.2025

Дата прийняття до друку статті 25.11.2025

UDC 004.8

**Oleksii Nesterenko**<sup>\*1</sup>

<sup>1</sup>Postgraduate student, Automation and Computer-Integrated Transport Technologies Department, National Transport University, M. Omelyanovicha-Pavlenko St., 1, Kyiv, 01010, Ukraine. ORCID: <https://orcid.org/0009-0008-7249-3189>.

\*Corresponding author: [nesterenko\\_ob@gsuite.duit.edu.ua](mailto:nesterenko_ob@gsuite.duit.edu.ua).

## Methodological Aspects and Models for Assessing the Effectiveness of Artificial Intelligence in Project Management

*Rapid integration of artificial intelligence (AI) into project management offers significant potential to improve productivity through data automation, performance monitoring and schedule optimization. However, challenges such as “effective inefficiency” and the variability of AI model output complicate the assessment of its effectiveness. This article analyses the methodological aspects of evaluating AI effectiveness in project management, classifies existing methods (benchmarks, explainable AI, mutual information, psychometrics), identifies key challenges (biases, lack of standards, ethical constraints), and proposes novel metrics- indicator of new competency activation (INCA), novelty coefficient in AI-Driven Project Management (NCAPM) and dynamic assessment of transition to new efficiency enabled by AI (DATNE) to measure innovation. The potential of these approaches for transport infrastructure projects is indicated, where AI allows for the creation of fundamentally new opportunities in planning, service forecasting, and resource optimisation. Future directions include hybrid metrics and integration with decision support systems. The study underscores the need for interdisciplinary approaches to adapt AI evaluation to resource constrained project management environments.*

**Keywords:** *model, machine learning, benchmark, performance assessment, methodology, cognitive models, systems analysis, project management, artificial intelligence, decision support system.*

**Introduction.** Recent studies suggest that, artificial intelligence (AI) demonstrates significant potential to enhance the productivity and added value of project managers by automating data collection and analysis, monitoring performance, and optimizing time planning and scheduling. In the context of project management, this opens opportunities for optimizing project roadmaps, budgeting, performance control, and improving adaptability to changing external conditions [1].

At the same time, the rapid development and implementation of AI is accompanied by a range of risks that may have a reverse effect on the effectiveness of management activities. One such risk is the phenomenon of so-called “effective inefficiency,” which manifests in excessive creation or delegation of irrelevant, non-urgent, or unnecessary tasks. This, in turn, can lead to the project manager’s attention being scattered, team overload, and a general decline in the quality of management functions [2].

Another notable risk is the variability of results generated by different AI models. Differences in architecture, training algorithms, and training data sources result in substantial differences in predictions or decisions, even for the same management scenarios. An example is the difference between standard large language models and those using the Mixture-of-Experts (MoE) architecture, which allows for scaling without a proportional increase in computational costs. In this architecture, the model has many specialized “experts” (neural networks or parts of them), but only a few are activated per request.

Thus, evaluating the effectiveness of AI solutions cannot be reduced merely to technical specifications or the number of operations per unit of time—a metric describing hardware computational performance (CPU/GPU). Although this metric is important for technical optimization, it does not reflect the real utility or relevance of a model in solving practical project management tasks.

**Analysis of the Latest Research and Problem Statement.** The existing body of scientific literature demonstrates a growing interest in methodologies for evaluating the effectiveness of artificial intelligence in management and organizational decision-making. Many studies focus on performance-oriented indicators, such as accuracy, processing speed, or cost efficiency, while others emphasize explainability, transparency, and trust in AI-driven systems [3-5].

Therefore, there is a need for comprehensive approaches to evaluating AI effectiveness in project management that combine technical, organizational, and economic criteria. This article aims to analyze current methods of AI efficiency assessment in project management, identify key challenges, and propose perspectives for overcoming them. Special attention is given to large language models. The article first reviews assessment methods, then discusses challenges, and finally suggests promising alternatives adapted to project management under resource constraints.

**Analysis of the Latest Research and Problem Statement.** The evaluation of artificial intelligence effectiveness has become a distinct and rapidly developing research field at the intersection of computer science, management, and systems analysis. Existing studies offer a wide range of conceptual and methodological approaches; however, they remain fragmented, heterogeneous, and often poorly aligned with the specific requirements of project management practice. In particular, the lack of unified criteria for assessing not only performance improvements, but also managerial impact and capability transformation, complicates both comparative analysis and practical adoption. Against this background, a systematic analysis and classification of existing AI performance evaluation methods is required in order to identify their applicability, limitations, and relevance to project management under conditions of uncertainty and limited human resources.

To clarify this methodological landscape, the present section is structured as a systematic analytical review of existing AI evaluation approaches. The analysis begins with a general classification of performance-based and capability-oriented methods, followed by a detailed examination of benchmarks, explainable artificial intelligence techniques, mutual information analysis, and psychometric approaches. This structure reflects the functional logic of project management practice, moving from technically measurable indicators toward methods that attempt to capture higher-level cognitive and managerial effects. The purpose of such structuring is to identify conceptual limitations and unresolved methodological gaps in existing research, which subsequently motivate the development of original evaluation models presented in the later sections of this article.

**Classification of AI performance evaluation methods.** With the increasing application of Artificial Intelligence (AI) across various domains particularly in project management, production, and business analytics, there is a growing need to establish reliable and reproducible methods for evaluating its effectiveness. However, this evaluation process remains a complex and multidimensional challenge. This complexity arises not only from the wide variety of AI solution types—ranging from automated agents to generative models - but also from the lack of universal metrics that would be relevant across all use cases.

In today's project management context, the effectiveness of AI cannot be reduced to questions of technical integration alone. Of critical importance is AI's impact on key managerial functions: whether it truly accelerates processes, enhances decision-making quality, reduces cognitive load on project managers, and delivers measurable economic benefits in both the short and long term. Answering these questions is vital for informed decision-making about AI integration into business processes. Yet without proper performance evaluation methods, these remain mere assumptions or subjective impressions. Therefore, the following sections of this paper provide an in-depth analysis of these questions and justify the need to adapt existing metrics to the specific challenges of project management under conditions of limited human resources.

One of the first steps toward effective evaluation is the formulation of clear, data-oriented objectives. The assessment methodology should be based on Key Performance Indicators (KPIs) that reflect the strategic priorities of the organization. Even so, identifying the actual impact of AI often entails a “chicken-and-egg” paradox: high-quality data is needed to deploy AI, but AI’s influence manifests precisely through improvements in data quality and availability.

The type of AI system also increases evaluation complexity. For instance, the effectiveness of predictive maintenance solutions can typically be assessed using straightforward metrics such as failure rate reduction. In contrast, generative AI systems used for employee training or organizational knowledge retention produce outcomes that are harder to quantify and require more sophisticated approaches to data collection and interpretation.

Contemporary approaches to AI evaluation fall into several categories: from performance-oriented methods that focus on achieving specific task outcomes, to capability-oriented methods that attempt to assess the underlying cognitive and functional abilities of AI systems. These are complemented by comprehensive business-oriented frameworks that measure return on investment (ROI) in AI, scalability of solutions, user-friendliness, the creation of fundamentally new capabilities, and the overall impact on workforce productivity [3].

Unlike some researchers [4] who express profound concerns about the potential negative consequences and existential risks associated with AI use, the authors of this paper do not fully share such apprehensions. Instead, they identify the key risk as ineffective AI implementation. This view is supported by the Massachusetts Institute of Technology (MIT) 2025 report on the state of AI in business, which states: “Despite investments of \$30–40 billion in generative AI, 95% of organizations report no significant returns on these investments” [5]. The absence of adequate quantitative assessment methods for AI integration leads many organizations to invest in these technologies without receiving the feedback necessary to refine their strategies. This in turn hampers rational evaluation and comparative analysis of projects, complicating their effective management and improvement. At the same time in recent years, the adoption of artificial intelligence across various business functions has accelerated significantly. According to McKinsey Global Surveys, the percentage of organizations using AI in at least one function surged from 55% in early 2023 to 78% by the end of 2024. This rapid growth is particularly evident in IT, marketing, and service operations. The IT function alone experienced a nine-point increase in reported AI adoption within six months - from 27% to 36% - highlighting the growing reliance on AI-driven tools for automation, risk prediction, and resource optimization.

Figure (1) illustrates the dynamics of AI adoption across different industries between 2020 and 2024, emphasizing the expanding role of AI in project management and strategic operations.

The key objective of this section is to systematize existing groups of AI performance evaluation methods, classify them, and analyze their relevance to project management tasks in resource-constrained environments.

**Traditional and Capability-Based Approaches to Evaluating AI Efficiency.** Traditional and capability-based approaches to evaluating the effectiveness of artificial intelligence (AI) in project management encompass methods that originated during the early phases of AI development or were adapted from adjacent disciplines. These approaches aim to assess technical performance, economic viability, and organizational impact.

Performance-based evaluation frameworks focus on measuring how well AI systems execute predefined tasks, such as scheduling, resource allocation, or risk prediction. In contrast, capability-based assessments examine the broader cognitive competencies of AI models, including reasoning, adaptability, and learning capacity. Both approaches have been applied to support project management functions through automation and decision support.

However, these methodologies exhibit notable limitations. Performance metrics are often static and insufficiently responsive to the rapidly evolving, uncertain, and resource-constrained environments characteristic of modern project management. Moreover, traditional indicators—such as task completion time or computational throughput - may not reflect the actual managerial value or practical utility of an AI solution in a project setting. Historically, these methods emerged during the development of

foundational AI theories, when the emphasis was placed on benchmarking hardware capabilities (e.g., CPU/GPU performance) or evaluating the return on investment (ROI) of AI-driven systems. At that time, less attention was paid to the complex reasoning abilities and generalization potential of modern AI architectures.

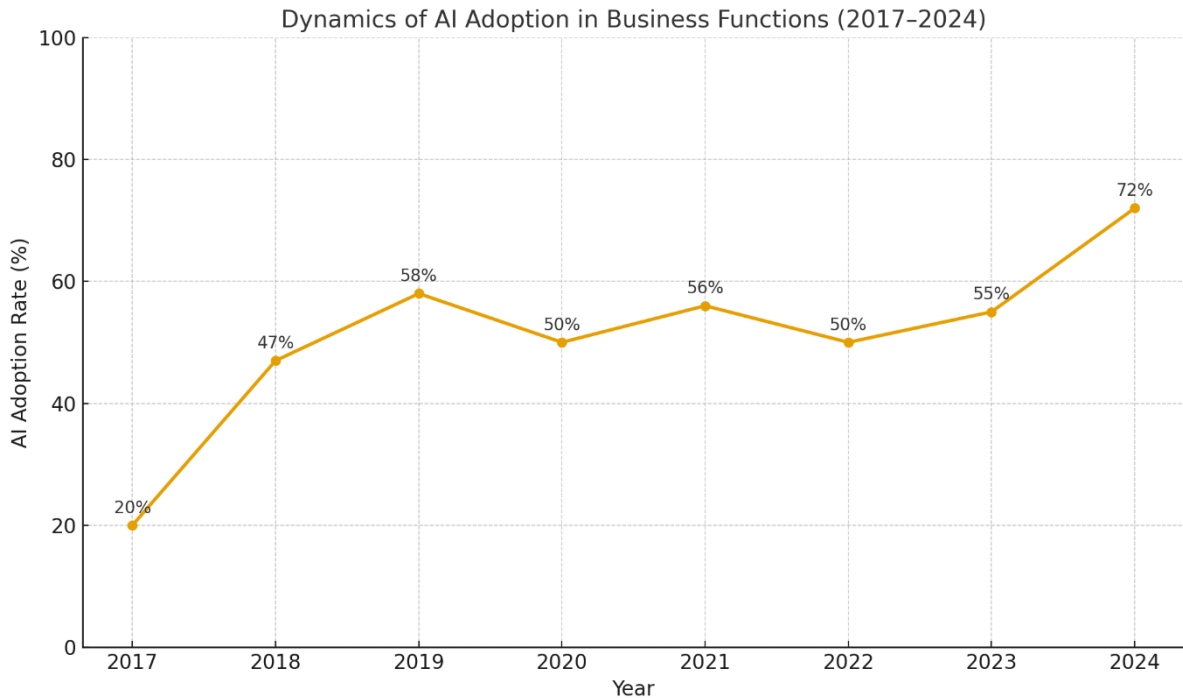

*Fig. 1. Share of organizations using AI in at least one business function, 2018–2024. Source: McKinsey & Company (2025).*

Consequently, while these legacy evaluation methods are still prevalent in industry and academia, they often fall short in addressing the demands of contemporary project management, especially under dynamic conditions and tight resource constraints. The following sections review the key methods within this category, examine their application to project environments, and outline the critical limitations that motivate the exploration of more adaptive, context-aware evaluation strategies presented later in this paper.

**Benchmarks.** In the context of artificial intelligence (AI) performance evaluation, benchmarks refer to standardized sets of tests, tasks, or metrics used to measure system characteristics such as accuracy, execution speed, data processing capacity, and reliability under controlled conditions. Benchmarks serve as a core tool in traditional evaluation methods, enabling consistent comparison of different AI models, assessment of their capabilities, and identification of limitations. However, it is important to note that benchmarks do not always reflect the complexity of real-world project management environments. Within project management (PM), benchmarks are commonly used to evaluate AI effectiveness in task specific areas such as automated scheduling, risk forecasting, or resource optimization.

One prominent benchmark is SuperGLUE (Super General Language Understanding Evaluation), developed as a more challenging successor to GLUE (General Language Understanding Evaluation). SuperGLUE was introduced to address the limitations of GLUE, where AI models had already surpassed the performance of non-expert humans. It consists of a suite of complex tasks aimed at testing language understanding capabilities, with a particular focus on low-resource learning scenarios. While GLUE reached or exceeded human-level performance, SuperGLUE focuses on tasks that remain difficult for algorithms but are solvable by educated humans.

The benchmark encompasses various formats - including classification, question-answering, causal reasoning, and disambiguation - and employs a unified evaluation system based on average scores across tasks

$$S_{core} = \frac{1}{N} \cdot \sum_{i=1}^N M_i, \quad (1)$$

where  $N$  is the number of tasks;

$M_i$  is the normalized model result for task  $i$ , measured by the appropriate metric.

SuperGLUE includes eight tasks. BoolQ is a yes/no question-answering task where models must find an answer in a short text excerpt, typically taken from Wikipedia, based on a search engine user query. Commitment Bank (CB) evaluates the model's ability to determine the degree to which the author believes in the truth of a subordinate clause; this task is essentially a variant of textual implication with three classes - entailment, contradiction, and neutrality. Choice of Plausible Alternatives (COPA) is built on causal relationships: the system is given a premise sentence and two possible alternatives for cause or effect, and it must choose the more logical one. MultiRC is a reading comprehension task where each question can have multiple correct answers; the model must not only identify them but also combine facts from different sentences in the text. ReCoRD presents news articles in a Cloze-style task where one entity is masked, and the correct variant must be selected from several possible candidates; the complexity lies in the fact that the entity can be expressed in the text in several different forms. Particular attention in SuperGLUE is paid to lexical and semantic polysemy. The Word-in-Context (WiC) task involves determining whether a word has the same meaning in two different contexts; it tests the model's ability to distinguish lexical polysemy. Even more challenging is the Winograd Schema Challenge (WSC) task, which requires the model to correctly interpret a pronoun in a sentence, relying not only on syntactic structure but also on common sense. Additional sets AX-b and AX-g are used for diagnosing the quality of implication task performance.

In addition to the main tasks, SuperGLUE includes a diagnostic dataset that allows analysis of model strengths and weaknesses. It includes examples aimed at testing logical operators, coreferences, temporal relationships, semantic roles, and polysemy. As a result, the benchmark not only determines the average performance level but also helps understand in which specific aspects of language understanding the model has limitations [6].

Despite its popularity in the scientific community, SuperGLUE as a benchmark does not provide insight into how effective an AI model can be for business. The reason lies in the nature of this method: it measures model performance in narrowly defined academic tasks that reduce to classification, text-based answer search, or implication determination. Such tasks do not reflect the complexities of real business processes.

Firstly, SuperGLUE tasks are artificial and limited in context. For example, choosing the correct pronoun in the Winograd Schema or determining word meaning in WiC has no direct analogy in business scenarios such as supply chain management, sales forecasting, or user data work. Thus, a high score on the benchmark does not mean the model can generate value in practical conditions.

Secondly, SuperGLUE does not account for economic metrics - implementation costs, integration speed, user training expenses, or return on investment. In business, key indicators include ROI, TCO, or reductions in operational costs, rather than the percentage of correct answers on a test sample. A model may perform excellently on benchmark tasks but be too expensive to operate or overly complex to integrate.

Thirdly, SuperGLUE lacks the dynamism characteristic of the market. Business environments change constantly, with data that is noisy, incomplete, or contradictory. In contrast, benchmark tasks are static and relatively "clean" creating a gap between academic evaluation and how a model behaves in real corporate applications.

Fourthly, SuperGLUE does not test a model's ability to work with domain-specific information. For example, companies in pharmaceuticals, agriculture, or finance have their own unique data, unlike

Wikipedia articles or news texts. High results on general tasks do not guarantee that a model can process complex legal documents, scientific patents, or technical specifications.

In conclusion, SuperGLUE evaluates the linguistic abilities of models but does not answer the question of how much economic value they can create. Businesses expect AI to deliver concrete benefits - faster decision-making, cost reduction, resource optimization, and profit growth—rather than abstract accuracy. Therefore, for corporate applications, specialized metrics and benchmarks that directly reflect business efficiency, rather than just linguistic skills, are needed.

The performance of modern large language models (LLMs) is commonly assessed across multiple dimensions, including reasoning, agentic tasks, and coding abilities. Figure 2 illustrates comparative results for 15 leading models across 12 benchmark suites, such as MMLU-Pro, AIME 24, SciCode, SWE-Bench, TAU-Bench, and others. Each model is evaluated by aggregating results in the following categories:

- agentic: Tasks that require planning, goal execution, and multi-step reasoning across benchmarks like TAU-Bench and BFCL V3;
- reasoning: Logic, mathematical problem-solving, and comprehension, as measured by MMLU-Pro, AIME 24, and LCB;
- coding: Software engineering challenges, including benchmark tasks like SWE-Bench and Terminal-Bench.

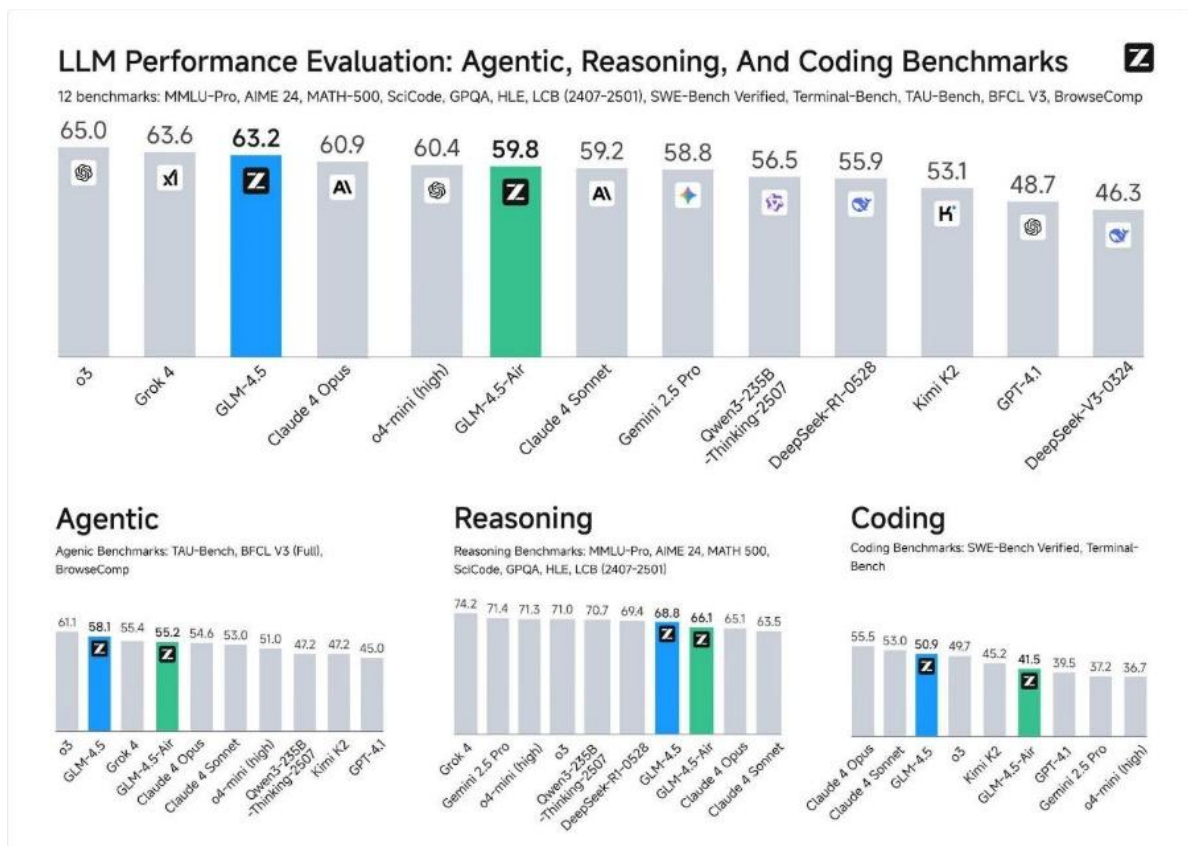

Fig.2. LLM Performance Evaluation: Agentic, Reasoning, And Coding Benchmarks Source: <https://z.ai/blog/glm-4.5>

In this evaluation, GLM-4.5 and its lightweight variant GLM-4.5-Air demonstrated competitive performance across all three categories. While GPT-4-o scored highest overall (65.0), GLM-4.5 achieved notable results in reasoning (68.8) and agentic benchmarks (58.1), outperforming some commercial models like Claude Opus and Gemini 2.5 Pro.

**Explainable Artificial Intelligence (XAI).** Explainable Artificial Intelligence (XAI) represents a set of methods and techniques aimed at ensuring the transparency of AI system decisions, particularly through the interpretation of the internal processes of models that often function as “black boxes”. In the context of project management (PM), XAI gains special significance, enabling project managers—who are not necessarily experts in machine learning—to understand the logic behind AI predictions, such as risk assessments or resource optimization. This method enhances trust in automated systems, identifies biases, and ensures compliance with ethical standards, which is critical in dynamic PM environments with limited resources [7].

Among the key XAI techniques are LIME (Local Interpretable Model-agnostic Explanations) and SHAP (SHapley Additive exPlanations), which explain how individual features influence a model’s predictions. While XAI provides qualitative evaluation through transparency and comprehensibility of decisions, its ability to quantitatively assess the effectiveness of implementing AI models is limited. XAI focuses on interpreting AI decisions, allowing project managers to evaluate the appropriateness of predictions.

The LIME method creates local approximations of complex models to explain individual predictions, minimizing a loss function

$$\operatorname{argmin}_{g \in G} L(f, g, \pi \cdot x) + \Omega(g), \quad (2)$$

where  $g$  is the local interpretable model;

$G$  is the set of simple, human-understandable models (e.g., linear regression, decision trees);

$L$  is the loss function measuring how much the predictions of the local model  $g$  differ from those of the complex model  $f$  in the local neighbourhood of point  $x$ , weighted by  $\pi \cdot x$  (the weight of the local region);  $\Omega(g)$  is a penalty for model complexity. In project management,  $\Omega(g)$  limits the number of features (e.g., budget, deadlines) used for explanation, ensuring project managers can easily grasp key factors [8].

In PM, LIME can explain why an AI predicts project delays by highlighting the impact of individual factors, such as resource shortages or unclear requirements. For example, a model  $g$  explaining the behaviour of  $f$  in the local neighbourhood of  $x$  might show that a project delay prediction depends 60% on a limited budget.

However, the LIME method has significant drawbacks, including:

- Locality of Explanations: The formula focuses on local approximation (via  $\pi \cdot x$ ), limiting generalization. In project management, where project conditions change (e.g., new requirements), an explanation for one  $x$  may not apply to another. For instance, an explanation for one project (with a budget of 100,000) may be irrelevant for another (with a budget of 1 million);

- Instability: Explanations depend on the choice of  $\pi \cdot x$  (e.g., kernel width  $\sigma$  and the generated dataset  $Z$ ). Changes in these parameters can lead to different  $g$  values, reducing reliability in project management, where consistency is needed. This can confuse managers if explanations for similar projects vary.

- Computational Complexity: Calculating  $L(f, g, \pi \cdot x)$  requires generating many points  $Z$  and evaluating  $f(z)$  for each, which can be resource-intensive for large models  $f$  (e.g., transformers). In project management, where quick decisions are needed, this can be a limitation [9].

- Subjectivity of Penalty  $\Omega(g)$ : The choice of  $\Omega(g)$  (e.g., limiting the number of features) is subjective and affects interpretability. In project management, managers may need explanations with varying levels of detail, but the formula does not adapt automatically.

- Lack of Quantitative Effectiveness Assessment: The formula does not measure how much implementing AI improves project metrics (e.g., reduced project completion time). It only explains predictions but does not evaluate their impact, for example, through metrics like ROI or KPIs [10].

Similarly, the SHAP method applies game theory to assess the contribution of each feature

$$\varphi_i = \sum_{S \subseteq N/\{i\}} \frac{|S|! \cdot (|N| - |S| - 1)!}{|N|!} \cdot [f_x(S \cup \{i\}) - f_x(S)], \quad (3)$$

where  $\varphi_i$  is the contribution of feature  $i$ ;

$S$  is a subset of features;

$N$  is the set of all features;

$f_x$  is the model prediction [11].

In project management, this allows, for example, determining how parameters such as team experience or budget influence project delays.

The process of using XAI to evaluate AI in PM involves selecting a technique (e.g., SHAP for global interpretation), generating explanations based on the model's output data, and interpreting them in the context of project decisions. Tools like SHAP or LIME libraries in Python are integrated with PM platforms, such as Jira, for real-time visualization of explanations.

However, XAI has significant limitations for quantitatively assessing the effectiveness of implementing AI models in project management. Firstly, XAI does not provide direct metrics to measure the impact of AI on key project indicators, such as reduced completion time, budget savings, or productivity improvements. For example, while SHAP can quantitatively assess feature contributions, it does not measure how much implementing AI improves overall project efficiency compared to traditional methods. Additional metrics, which XAI does not generate automatically, are needed, such as the percentage reduction in delays

$$\Delta T = \frac{T_{nonAI} - T_{withAI}}{T_{nonAI}} \cdot 100\%, \quad (4)$$

or resource savings

$$\Delta R = R_{nonAI} - R_{withAI}. \quad (5)$$

Secondly, XAI methods like SHAP require significant computational resources, which can be problematic in PM environments with limited budgets or hardware, especially for real-time applications, such as IoT project monitoring.

Thirdly, the lack of standardized metrics for evaluating the quality of explanations complicates comparing AI effectiveness across different projects or models. For example, there is no universal criterion to quantitatively assess how useful SHAP or LIME explanations are for project managers, limiting their applicability for comparative analysis.

Thus, XAI is a valuable tool for qualitative evaluation of AI in project management, providing transparency and comprehensibility of decisions. However, its limitations in quantitative effectiveness assessment, high computational complexity, explanation instability, and lack of standardization indicate the need to combine XAI with traditional PM metrics, such as ROI or KPIs, for a comprehensive evaluation of AI impact. Further research should focus on developing standardized approaches to integrating XAI with PM platforms and creating quantitative metrics that evaluate not only explanations but also the overall effectiveness of AI in project management.

**Mutual Information (MI) and Model Inspection** are methods for evaluating the internal workings of AI systems, aimed at analysing the information that a model actually captures and uses for its predictions. In the context of project management (PM), these methods allow for a deep understanding of how AI processes data, for example, how internal model representations reflect dependencies between project features (budget, deadlines, risks), contributing to the identification of inefficiencies and optimization of decisions. MI measures the dependency between input data and the model's internal states, while model inspection involves analysing layers, activations, and weights, providing a detailed overview of AI functioning [12]. The essence of MI lies in the quantitative assessment of

interdependence between variables, for example, between input features (X) and the model's internal representations (Y). The MI formula is based on information theory

$$I(X, Y) = \sum_{x, y} p(x, y) \cdot \log \frac{p(x, y)}{p(x) \cdot p(y)}, \quad (6)$$

where  $p(x, y)$  is the joint probability distribution;  $p(x)$  and  $p(y)$  are the marginal distributions [13].

In project management, MI can analyse how much an AI model captures dependencies between project features, for example, how budget data influences layer activations for risk forecasting. Model inspection complements MI through the direct analysis of internal components: neural network layers, neuron activations, and connection weights. For instance, visualization techniques like t-SNE (for dimensionality reduction) allow one to see how a model clusters project data, while weight analysis (e.g., via gradient methods) identifies key features. In project management, this can be used to verify whether a model effectively processes data from tools like Jira, for example, how layer activations reflect the impact of team size on delay estimates.

Despite their advantages, MI and model inspection methods have significant limitations for evaluating AI effectiveness in PM.

Firstly, high computational complexity: calculating MI for large models with N features has exponential complexity due to the need to estimate joint distributions, making it unsuitable for real-time evaluation in resource- constrained project environments.

Secondly, the need for high technical expertise: interpreting MI results or activation visualizations requires machine learning expertise, which may be unavailable to project managers, leading to misapplications.

Thirdly, instability with dynamic data: MI depends on data quality, and thus MI values may vary, complicating comparative analysis of models.

Fourthly, limited scalability: for deep models with millions of parameters, inspecting layers (e.g., weight analysis) becomes practically impossible without specialized hardware, reducing its usefulness in projects with limited budgets. Finally, the lack of standardization: there are no unified metrics for assessing the quality of MI or inspection, making them subjective and less suitable for quantitative comparison of AI model effectiveness across different scenarios.

Thus, MI and model inspection provide a deep understanding of AI's internal workings, which is valuable for optimizing models in project management. However, their limitations in computational complexity, need for expertise, and instability in dynamic environments indicate the necessity of combining them with other methods, such as benchmarks or XAI, for a comprehensive effectiveness evaluation.

**Psychometrics**, traditionally used to assess human cognitive abilities such as intelligence, memory, or abstract thinking, is adapted for evaluating AI systems through analogy with human tests. In the context of project management, psychometrics allows the assessment of AI's "cognitive abilities" for example, its capacity for analysing causal relationships, solving complex planning tasks, or generating creative solutions for resource optimization. This method goes beyond standard performance metrics, focusing on evaluating the general intellectual capabilities of AI, which is particularly valuable in dynamic environments requiring adaptability to changing conditions. However, psychometrics faces challenges in formalization and the risk of anthropomorphism, which limits its practical application. The essence of psychometrics in AI evaluation lies in applying tests similar to those used for humans, such as IQ tests, analogies, causal reasoning, or linguistic creativity assessments. In project management, this may include evaluating an AI's ability to analyse dependencies between project factors (e.g., how budget changes affect deadlines) or generate innovative resource allocation strategies. For example, an analogy test can check whether an AI can map the relationship "budget/risk" to other pairs like "resources/productivity," reflecting its abstract thinking capacity. A causal reasoning test can assess how

an AI determines that a resource shortage causes project delays. Formally, psychometric evaluation can be represented through an assessment function:

$$S = f(T, R), \quad (7)$$

where  $S$  is the psychometric score;

$T$  is a set of tests (e.g., on analogies or memory);

$R$  is the AI's responses, compared to benchmark or human results [14].

**Methods for Measuring Fundamentally New Capabilities Created by AI.** A number of metrics and frameworks have been specifically designed to assess fundamentally new capabilities enabled by artificial intelligence (AI), where the baseline performance was initially zero. Unlike traditional percentage-based productivity improvements - which require a non-zero baseline for comparison - these metrics focus on the emergence of new skills, processes, or functions that were previously unavailable. They are often classified as indirect or business-oriented metrics and typically combine quantitative indicators with qualitative assessments, such as maturity levels.

The following analysis draws from both academic and business literature, with a focus on project management and managerial productivity enhancement.

**Maturity-Based AI Metrics** evaluate an organization's progress in implementing AI by measuring the transition from no capability to new capabilities across a predefined scale (e.g., from level 1 to level 5). These metrics capture the transformative impact of AI, such as enabling software development by non-technical project managers, or the creation of novel project processes like risk prediction or resource optimization. They are crucial for assessing the influence of AI on project-related activities, especially in environments with constrained resources.

Example: The McKinsey AI Maturity Model assesses AI adoption using key performance indicators such as the number of AI-driven use cases deployed and the percentage of revenue generated from AI initiatives. If a project manager previously had no ability to code, this model measures the shift from 0 to a number of real business cases involving AI (e.g., from 0 to 15 projects per year involving automated coding capabilities), with a focus on the pace at which new functionality is created [15].

**Innovation and Novelty Creation Metrics.** Innovation capacity is a key performance indicator for modern organizations seeking long-term competitiveness in dynamic markets. A critical aspect of evaluating AI implementation in project management involves measuring innovation outcomes directly attributable to AI technologies. These metrics aim to quantify an organization's ability to generate entirely new products, services, or processes - that is, radical innovations.

Several types of metrics are used to measure innovation performance, including:

Quantitative metrics:

- number of patent applications (patent activity);
- number of new products or services launched;
- number of scientific publications, technical reports, or prototypes;
- share of R&D budget allocated to experimental AI initiatives.

Qualitative metrics:

- radicalness of innovation (i.e., departure from existing technologies);
- ability of AI to autonomously generate novel ideas;
- expert-based assessment of novelty using the Delphi method.

One of the core quantitative metrics is the Innovation Effectiveness Index

$$I_{innovation} = \frac{N_{patents} + N_{new\_products} + N_{scientific\_outputs}}{T}, \quad (8)$$

where  $N_{patents}$  is the number of patents filed during the evaluation period;

$N_{new\_products}$  is the number of novel product/service launches;

$N_{scientific\_outputs}$  is the count of relevant technical or academic outputs.

Generative AI models (e.g., LLMs, GANs, diffusion models) act as innovation catalysts by:

- supporting idea generation in creative sessions;
- performing automated patent analysis to identify technological gaps;
- simulating and testing innovative concepts in virtual environments;
- generating AI-driven product design prototypes.

In project management, this enables non-intuitive solution generation, especially by less experienced managers. For example, large language models (such as ChatGPT, Claude, or Gemini) can autonomously produce multiple project planning scenarios based on minimal input, thus facilitating novel approaches to resource, time, or budget planning. Example: The number of patents filed as a direct result of AI capabilities (e.g., increasing from 0 to 10 per year) represents the creation of new research potential. In project management, this may include AI-driven generation of planning methodologies for novice project leads. According to a recent study [16], AI-related patent filings are growing at an annual rate exceeding 30%, confirming AI's critical role as an innovation engine.

Such innovation metrics should be treated not only as reporting indicators, but also as strategic signals of digital transformation effectiveness. Their dynamic monitoring via internal dashboards enhances an organization's adaptability within a VUCA environment.

**Metrics for Human Capital Development Driven by AI.** AI deployment in project management should be evaluated not only through technical and financial indicators, but also through its impact on human capital transformation. Human capital metrics reflect qualitative and quantitative shifts in staff skills, knowledge, and productivity - particularly when baseline digital or AI competence was previously lacking. A common approach involves administering digital literacy questionnaires or assessments to track growth in knowledge and confidence when interacting with AI systems.

For instance, a Digital AI Literacy Index ( $L$ ) can be calculated as

$$L = \frac{N_{qualified}}{N_{total}} \cdot 100\%, \quad (9)$$

where  $N_{qualified}$  is the number of employees demonstrating at least basic AI system understanding;  $N_{total}$  is the total number of participants assessed.

Another valuable metric is the share of staff who completed AI-related training or certification within a defined period (e.g., annually). This serves as an indicator of the effectiveness of internal personnel development programs or external educational initiatives.

In project-oriented environments, such metrics help evaluate the extent to which AI can compensate for shortages in skilled labour by automating routine tasks and offering decision-making support.

Table 1 provides a comparative overview of key AI evaluation approaches across various domains of project management impact.

**Table 1. Overview of AI Evaluation Methods and Their Applications in Project Management**

Method Category	Example Metric	Application Area	Evaluation Focu
Technical Effectiveness	Accuracy, Latency, F1-Score	Predictive tools	System performance
Business Efficiency	ROI, NPV, Time savings	Strategic and operational decisions	Financial impact
Innovation Impact	Patents, Novelty index	R&D, product pipeline enhancement	New value creation
Human Capital Development	AI training rate, Skill index	Workforce AI adoption	Capability building
Organizational Maturity	AI maturity models	Implementation roadmaps	Transformation stage

**The Purpose and Objectives of the Research.** The purpose of this research is twofold and reflects a transition from analytical assessment to methodological development in the evaluation of artificial intelligence effectiveness in project management.

The first objective of the study is to conduct a structured analytical review of existing methods for evaluating the effectiveness of artificial intelligence in project management. This includes the classification and critical examination of performance-based, interpretability-oriented, and maturity-based evaluation approaches, as well as the identification of their conceptual and methodological limitations when applied to dynamic and resource-constrained project environments.

The second objective of the study is to develop original methodological approaches for assessing artificial intelligence effectiveness in “zero-to-one” scenarios, where AI enables fundamentally new managerial capabilities that were previously unavailable. These approaches are aimed at capturing AI-induced transformations in decision-making, task feasibility, and project execution, which cannot be adequately evaluated using traditional productivity or maturity metrics.

**Novel Approaches to Measuring the Effectiveness of AI Application in Project Management.** Based on a critical analysis of existing approaches to measuring the effectiveness of artificial intelligence (AI) implementation in management practices, particularly in project management, three original evaluation methods are proposed. These methods have not been adequately described in contemporary scientific literature. Most existing studies focus on classical metrics such as Key Performance Indicators (KPIs), Return on Investment (ROI), or technology adoption maturity models. In contrast, the proposed approaches emphasize under-explored aspects, including: the dynamics of transitions from a baseline to an innovative level (“zero-to-one transitions”), the interaction between artificial intelligence and project management methodologies (notably aligned with the Project Management Institute standards), and the use of explainable AI models alongside ethical decision-making components. Each method includes a description, formula/algorithm, application, and potential for empirical validation. These methods can benefit organizations aiming to integrate intelligent tools into management processes - not only to enhance productivity but also to develop new training approaches for personnel, automate decision-making, and ensure transparency in human-algorithm interactions under conditions of uncertainty. It is worth noting that these methods do not duplicate each other but form a comprehensive evaluation system.

**Indicator of New Competency Activation (INCA) in Project Management.** The INCA index introduces a novel metric focused not on the efficiency of performing existing tasks but on measuring the emergence of new competencies and functions arising from AI application. This distinguishes it from classical approaches - such as KPIs, ROI, or maturity models - which assess only productivity or the maturity level of technology adoption. The scientific novelty lies in three aspects:

- **Conceptual**: The introduction of the “zero-to-one transition” concept in the context of project management, i.e., the shift from the absence of a capability to its emergence through AI.
- **Methodological**: A formula is proposed that combines the number of new tasks, their impact on project outcomes, and their explainability (XAI-score).
- **Analytical**: Integration of XAI (explainable AI) with the PMI PMBOK model allows not only measuring the effect but also explaining the mechanism of its occurrence.

The INCA index is an integral metric calculated as follows

$$INCA = \frac{\sum_{i=1}^T (N_i \cdot I_i \cdot E_i)}{T}, \quad (10)$$

where  $N_i$  – the number of new tasks  $i$  made possible (ranging from 0 to  $T$ );  
 $I_i$  – impact on the project (scored from 0 to 1, based on PMI scale: impact on timelines, budget, quality);  
 $E_i$  – explainability (XAI-score, e.g., SHAP value for LLM, ranging from 0 to 1, where 1 indicates full transparency);

$T$  – the total number of tasks in the project.

An example application in an IT project could involve a manager who does not code generating code using AI. INCA would measure this as a transition from 0 to 10 new modules, with an impact on the budget ( $I_i=0.8$ ) and explainability ( $E_i=0.7$ ), yielding an overall index for assessing implementation effectiveness.

Thus, the index serves as a dynamic indicator of competency development, which can be empirically validated. To verify its reliability,  $A/B$  testing is recommended: one group of managers works with AI support, while another does not. Comparing the mean INCA values between groups, followed by a statistical test (e.g., Student's t-test), would quantitatively demonstrate AI's impact.

INCA can be integrated into project management maturity assessment systems or internal PMO dashboards. It enables the identification of competencies activated by AI (rather than merely improved) and the assessment of the relationship between new skills and reduced risks or costs. Additionally, this method can be used to develop competency maps, where INCA acts as an indicator of training, innovativeness, and digital maturity. Compared to traditional approaches, INCA aligns more closely with evolutionary metrics of organizational intelligence development, making it suitable for strategic analysis.

**Novelty Coefficient in AI-Driven Project Management (NCAPM).** The NCAPM is an original metric for evaluating the innovative potential of AI in project management through a combination of qualitative (expert novelty assessment) and quantitative (scenario simulation) metrics. The metric is based on the integration of generative AI for modelling “what-if” scenarios in project management (e.g., real-time risk forecasting). This approach is absent in existing KPIs or innovation speed metrics, which typically do not account for ethical dilemmas associated with novel solutions. The coefficient is calculated as follows

$$NCAMP = \frac{Q_n + S_n - B_n}{3}, \quad (11)$$

where  $Q_n$  – qualitative novelty assessment (expert score from 0 to 10);

$S_n$  – simulation assessment (number of unique scenarios generated by LLM, ranging from 0 to  $n$ , with uniqueness verified via NLP analysis);

$B_n$  – correction for ethical ambiguities (ranging from 0 to 1, based on the NIST AI Risk Framework, for ethical novelty).

An example application in a construction project might involve AI creating a new risk simulation capability for non-technical managers. The coefficient would measure novelty as 8/10 ( $Q_n$ ), with 50 scenarios ( $S_n=0.9$ ), minus ambiguity ( $B_n=0.2$ ), yielding a coefficient for assessing implementation effectiveness.

**Dynamic Assessment of Transition to New Efficiency En-abled by AI (DATNE).** This metric tracks dynamic transitions from a baseline to a new efficiency level in real-time, integrating Internet of Things (IoT) data with project management tools and AI systems. The metric enables real-time monitoring using agent-based AI systems (agents based on large language models), a feature absent in static maturity models or task completion indicators, with a focus on the adaptability of project management to changes, especially during crisis situations.

The coefficient is calculated as follows

$$DANTE = \int \frac{C_t - C_0}{\Delta T} dt, \quad (12)$$

where  $C_t$  – capability level at a specific time  $t$ , a numerical indicator ranging from 0 to 1, reflecting the ability of a team or individual to perform new task types previously unavailable without AI or digital tools.

This level can be objectively measured using IoT device data, which records actual changes in behaviour or system performance.

The capability level has the following formalized representation

$$C(t) = \frac{Z(t)}{Z_{max}}, \quad (13)$$

where  $C(t)$  – capability level at time  $t$ ;

$Z(t)$  – number of new completed tasks made possible by the intelligent system at time  $t$ ;

$Z_{max}$  – the maximum possible number of such tasks in the project (defined during the planning phase). -

$C_0$  – baseline level (0 for a project without AI);

$\Delta T$  – observation period (e.g., one week of the project).

An example calculation of the capability level can be provided. Within a project to modernize a production line in a food industry enterprise, the project team implemented a data analysis system based on intelligent sensors. Previously, operators could not identify equipment anomalies in real-time. After implementation - thanks to automatic alerts from the system - the team was able to respond promptly to 9 new event types. The total number of tasks potentially executable with this system was 15. Thus, the capability level one month after implementation can be calculated as  $C(t)=9/15=0.6$ . This indicates a 60% realization of new capabilities that were impossible before integrating the intelligent module.

The DATNE metric can be applied, for example, in an agile project where a manager gains a new real-time budget adjustment capability through AI. This indicator allows for a quantitative assessment not only of productivity but also of the level of digital transformation and team adaptation to new tools, which is critical in modern project management.

**Challenges and Prospects for Evaluating the Effectiveness of AI Application in Project Management.** Evaluating the effectiveness of AI application in project management faces numerous challenges, both technical and methodological in nature [9]. One key issue is the lack of established standards. Most existing methods are developed primarily within specific use cases [18], making them difficult to compare or scale to broader contexts, which hinders standardization [4].

Moreover, methodological barriers exist. For instance, many metrics are subjective or lack external validity testing [14]. Anthropomorphism is often observed, where AI systems are attributed human qualities or intentions [21]. Another problem is the presence of “noise” in training datasets, where models exhibit reduced effectiveness due to incorrect or publicly available benchmark data [22]. This is particularly relevant in fields like software development, where it is challenging to work with unstable application programming interfaces, new or external domains, and languages with limited resources [6].

From a technical perspective, difficulties arise from biases in data - measurement, labelling, selection, aggregation, confirmation, and others - which can lead to unfair treatment of different user groups [7]. Challenges also include privacy concerns, such as attempts to extract personal information from statistical models, data poisoning, and adversarial scenarios, necessitating the implementation of differential privacy mechanisms and distributed learning.

Ethical and legal constraints pose additional complexity. Data collection for analysis is often hindered by personal data protection regulations, internal company policies, or national legislative restrictions. This is particularly relevant for metrics requiring continuous real-time monitoring of personnel or user behaviour, as in the case of the dynamic transition assessor.

One of the central challenges in evaluating the effectiveness of AI systems in project management lies in the lack of unified mathematical frameworks that adequately describe the internal logic and decision-making mechanisms of large language models (LLMs). Even foundational elements of transformer-based architectures require complex mathematical justification, involving high-dimensional vector representations and optimization theories such as stochastic gradient descent and regularization techniques. Without a clear mathematical understanding of these systems, the development of reliable evaluation metrics for their application in dynamic, multi-variable environments like project management becomes problematic. This complexity highlights the need for interdisciplinary approaches

that combine project management methodologies with computational models and applied mathematics to ensure explainability, repeatability, and control of AI-driven project decisions [20].

Despite these challenges, there are clear directions for further development. One promising approach is the creation of hybrid metrics that combine technical characteristics (e.g., model interpretability, simulation accuracy, scenario generation efficiency) with classical management criteria (adherence to timelines, budget, quality). Another important direction is the integration of AI into decision support systems, where the model can not only provide recommendations but also self-assess their effectiveness.

The implementation of automated audit mechanisms is also advisable - language agents can analyse project documentation, compare actual results with planned ones, generate reports, and identify patterns in AI usage. Comparative testing of different models under practical project management conditions is also promising, enabling empirical evaluation of each approach's strengths and weaknesses.

Another significant direction involves integration with cognitive sciences to develop reliable psychometric tests and the creation of ethical evaluation frameworks, standardization of bias reduction processes in data, and the implementation of data governance policies. Simultaneously, particular attention is needed for large-context models capable of accounting for complex dependencies in dynamic project management environments, including the use of new architectures that combine algorithmic memory and intelligent information reproduction.

Thus, despite numerous barriers, the development of evaluating the effectiveness of AI application in project management represents a highly promising research direction. Its further advancement requires a multidisciplinary approach, combining project management, artificial intelligence, ethics, psychology, and data engineering.

Particular attention should be given to the potential of these approaches for transport infrastructure projects, where the application of AI enables the emergence of zero-to-one capabilities - functions that did not previously exist in traditional engineering or management systems. For instance, intelligent agents integrated into transport project management platforms can autonomously generate maintenance forecasts for rail tracks or highway pavements using IoT sensor data, optimize the sequencing of construction tasks based on real-time traffic models, and dynamically allocate resources to reduce downtime in rolling-stock operations. These capabilities represent a transition from reactive to predictive management, transforming the way infrastructure projects are planned, maintained, and financed. The integration of metrics such as INCA, NCAPM, and DATNE into these domains would allow quantifying the emergence of such fundamentally new competencies, thereby forming a methodological basis for evaluating innovation efficiency in digitalized transport ecosystems

**Conclusions.** This study addressed the methodological problem of evaluating the effectiveness of artificial intelligence (AI) in project management, where traditional performance indicators increasingly fail to reflect the actual managerial impact of AI-enabled systems. The results demonstrate that while artificial intelligence has significant potential to enhance planning, budgeting, risk forecasting, and decision-making processes, its effectiveness cannot be adequately assessed without a differentiated methodological framework that accounts for both existing evaluation approaches and emerging AI-driven capabilities.

The first research task - focused on the analysis of existing methods for assessing AI effectiveness - was addressed through a structured classification and critical examination of contemporary evaluation approaches. Traditional methods, including benchmarks, explainable artificial intelligence techniques, mutual information analysis, psychometric assessments, and maturity-based models, were systematized according to their evaluation focus and applicability to project management environments. The analysis showed that benchmarks (e.g., SuperGLUE) provide a standardized basis for comparing model performance but neglect the dynamic, contextual, and managerial nature of project work. Explainability-oriented and capability-based approaches improve transparency and insight into model behavior, yet their practical use is often constrained by high computational requirements, the need for specialized expertise, and limited comparability across projects. Maturity-based models capture organizational adoption dynamics but remain largely descriptive and do not explain how AI alters managerial effectiveness. Across all reviewed approaches, persistent limitations were identified,

including the lack of unified standards, susceptibility to data bias, anthropomorphic interpretations of AI behavior, and ethical and legal constraints, all of which hinder comprehensive quantitative evaluation in project management practice.

The second research task - aimed at developing methodological approaches for evaluating artificial intelligence effectiveness in “zero-to-one” scenarios - was addressed through the formulation of original, innovation-oriented evaluation metrics: INCA, NCAPM, and DATNE. These metrics shift the analytical focus from incremental productivity improvements toward the assessment of AI-enabled transitions from the absence of capability to its emergence. The proposed approaches enable the measurement of newly activated managerial competencies, qualitative novelty in project decision-making, and dynamic changes in effectiveness over time.

Based on the results obtained for both research tasks, the study outlines directions for further development of AI effectiveness evaluation. These include the creation of hybrid metrics combining technical, managerial, and ethical dimensions; the integration of advanced evaluation models into decision support systems; and the use of automated audits based on intelligent agents. Further empirical validation of the proposed methods in real project settings and their alignment with project management standards are identified as necessary steps toward broader practical adoption.

Overall, the study confirms that a comprehensive evaluation of artificial intelligence in project management requires a multidisciplinary approach that integrates computer science, systems analysis, and management science. The findings provide a coherent methodological foundation for assessing both existing AI applications and fundamentally new AI-enabled capabilities, contributing to the sustainable and responsible development of AI-driven project management practices.

## REFERENCES

1. Müller, R., Locatelli, G., Holzmann, V., Nilsson, M., & Sagay, T. (2024). Artificial intelligence and project management: Empirical overview, state of the art, and guidelines for future research. *Project Management Journal*, 55(1), 9-15. <https://doi.org/10.1177/87569728231225198>.
2. Mills, S., & Spencer, D. A. (2025). Efficient Inefficiency: Organisational challenges of realising economic gains from AI. *Journal of Business Research*, 189, 115128. <https://doi.org/10.1016/j.jbusres.2024.115128>.
3. Edwards, J. (2025). How To Measure AI Efficiency and Productivity Gains. In: *InformationWeek*, ed. *AI and Machine Learning Insights*. Available from: <https://www.informationweek.com/machine-learning-ai/how-to-measure-ai-efficiency-and-productivity-gains>.
4. Burden, J. (2024). Evaluating ai evaluation: Perils and prospects. *arXiv preprint arXiv:2407.09221*. <https://doi.org/10.48550/arXiv.2407.09221>.
5. Challapally, A., & Pease, C. (2025). AI trends and innovations in 2025. In: *Artificial Intelligence News*, ed. Annual AI Report. Available from: <https://www.artificialintelligence-news.com/wp-content/uploads/2025/08/aireport2025.pdf>.
6. Wang, A., Pruksachatkun, Y., Nangia, N., Singh, A., Michael, J., Hill, F., ... & Bowman, S. (2019). Superglue: A stickier benchmark for general-purpose language understanding systems. *Advances in neural information processing systems*, 326 1-15. <https://doi.org/10.48550/arXiv.1905.00537>.
7. Zhang, M., Wang, H., Li, J., & Gao, H. (2020). Learned sketches for frequency estimation. *Information Sciences*, 507, 365-385. <https://doi.org/10.1016/j.ins.2019.08.045>.
8. Ribeiro, M. T., Singh, S., & Guestrin, C. (2016, August). "Why should i trust you?" Explaining the predictions of any classifier. In *Proceedings of the 22nd ACM SIGKDD international conference on knowledge discovery and data mining* (pp. 1135-1144). <https://doi.org/10.1145/2939672.2939778>.
9. Arrieta, A. B., Diaz-Rodriguez, N., Del Ser, J., Bennetot, A., Tabik, S., Barbado, A., ... & Herrera, F. (2020). Explainable Artificial Intelligence (XAI): Concepts, taxonomies, opportunities and challenges toward responsible AI. *Information fusion*, 58, 82-115. <https://doi.org/10.1016/j.inffus.2019.12.012>.
10. Doshi-Velez, F., & Kim, B. (2017). Towards a rigorous science of interpretable machine learning. *arXiv preprint arXiv:1702.08608*. <https://doi.org/10.48550/arXiv.1702.08608>.
11. Lundberg, S. M., & Lee, S. I. (2017). A unified approach to interpreting model predictions. *Advances in neural information processing systems*, 30. <https://doi.org/10.48550/arXiv.1705.07874>.
12. Olah, C., Mordvintsev, A., & Schubert, L. (2017). Feature visualization. *Distill*, 2(11), e7. <https://distill.pub/2017/feature-visualization>.
13. Tishby, N., Pereira, F. C., & Bialek, W. (2000). The information bottleneck method. *arXiv preprint physics/0004057*. <https://doi.org/10.48550/arXiv.physics/0004057>.
14. Hernandez-Orallo, J., 2017. Evaluating intelligence across species and machines. *The Measure of All Minds*, ed. *Cognitive Science Series*. Cambridge, UK: Cambridge University Press, 50–100. <https://doi.org/10.1017/9781316596654>.

15. McKinsey & Company. (2023). Generative AI's impact on business in 2023. In: The State of AI Report, ed. Digital Transformation Insights. New York, NY: McKinsey & Company, 10–25. Available from: <https://www.mckinsey.com/business-functions/mckinsey-digital/our-insights/the-state-of-ai-in-2023>.
16. WIPO (2023). *Trends in AI technology development*. Technology Trends 2023: Artificial Intelligence, ed. IP Research Series. Geneva, Switzerland: World Intellectual Property Organization.
17. Mehrabi, N., Morstatter, F., Saxena, N., Lerman, K., & Galstyan, A. (2021). A survey on bias and fairness in machine learning. *ACM computing surveys (CSUR)*, 54(6), 1-35. <https://doi.org/10.1145/3457607>.
18. MIT (2025). *Business applications of AI in 2025*. The State of AI in Business 2025, ed. Technology Insights. Cambridge, MA: MIT Press, pp.5–20. Available from: <https://www.mit.edu/ai-report-2025>.
19. Doshi-Velez, F., & Kim, B. (2017). Towards a rigorous science of interpretable machine learning. *arXiv preprint arXiv:1702.08608*. <https://doi.org/10.48550/arXiv.1702.08608>.
20. Nesterenko O., & Kulbovskiy I. (2024). Mathematical framework of transformer-based artificial intelligence architectures in large language models for the development of intelligent agents. *Science and technology today*, 5(46). [http://dx.doi.org/10.52058/2786-6025-2025-5\(46\)-1860-1872](http://dx.doi.org/10.52058/2786-6025-2025-5(46)-1860-1872).

**Нестеренко О.Б.<sup>1</sup>**

<sup>1</sup>Аспірант, Кафедра Автоматизація та комп'ютерно-інтегровані технології транспорту, Національний транспортний університет, вул. Михайла Омеляновича-Павленка, 2, 01010, м. Київ, Україна. ORCID: <https://orcid.org/0009-0008-7249-3189>.

### **Методологічні аспекти та моделі оцінки ефективності штучного інтелекту в управлінні проєктами.**

**Анотація.** Швидка інтеграція штучного інтелекту в управління проєктами пропонує значний потенціал для підвищення продуктивності завдяки автоматизації даних, моніторингу ефективності та оптимізації розкладів. Однак виклики, такі як "ефективна неефективність" та варіативність результатів моделей ШІ, ускладнюють оцінку ефективності. У статті аналізуються методологічні аспекти оцінки ефективності ШІ в управлінні проєктами, класифікуються існуючі методи (бенчмарки, пояснювальний штучний інтелект, взаємна інформація, психометрія), ідентифікуються ключові виклики (упередження, відсутність стандартів, етичні обмеження) та пропонуються нові метрики (ПАНК, КНУПШ, ДОПШ) для вимірювання інновацій. Зазначено потенціал цих підходів для проєктів транспортної інфраструктури, де ШІ дає змогу створювати принципово нові можливості в плануванні, прогнозуванні обслуговування та оптимізації ресурсів. Перспективи включають гібридні метрики та інтеграцію з системами підтримки прийняття рішень. Дослідження підкреслює необхідність міждисциплінарних підходів для адаптації оцінки ШІ до середовищ в управлінні проєктами з обмеженими ресурсами.

**Ключові слова:** Модель, машинне навчання, бенчмарк, оцінка ефективності, методологія, когнітивні моделі, системний аналіз, управління проєктом, штучний інтелект, система підтримки прийняття рішень.

Дата першого надходження статті до видання 11.09.2025

Дата прийняття до друку статті 24.11.2025

UDC 004.7:621.331:656.2

**Oleksii Danak** <sup>\*1</sup>

<sup>1</sup>Postgraduate student, Automation and Computer-Integrated Transport Technologies Department, National Transport University, M. Omelyanovicha-Pavlenko St., 1, Kyiv, 01010, Ukraine. ORCID: <https://orcid.org/0009-0000-3595-9391>.

\*Corresponding author: [danak\\_oyu@gsuite.duit.edu.ua](mailto:danak_oyu@gsuite.duit.edu.ua).

## Conceptual principles of building intelligent computer networks for monitoring energy consumption of railways

*The paper presents a conceptual approach to creating intelligent computer networks for monitoring and managing energy consumption in railway transport, which serve as the technological foundation for implementing the Smart Grid concept in the industry. Theoretical foundations of the transition from traditional electricity metering systems to integrated Smart Grid class systems are reviewed. Existing information flows in traction power supply systems are analyzed, and their main shortcomings are identified: data discreteness, lack of synchronization with train schedules, and low responsiveness of decision-making. A multi-level network architecture is proposed, including a data collection layer (IoT sensors, Smart meters), a communication layer (heterogeneous communication channels), a processing layer (cloud computing), and an application layer. The principles of integrating data on train movement and substation operation modes within a single information space are described. Requirements for reliability, cybersecurity, and speed of such a network are discussed. It is concluded that the implementation of the proposed concept will allow moving from passive observation to active energy management, which is a prerequisite for further mathematical optimization of railway operation modes.*

**Keywords:** *intelligent networks, Smart Grid, railway transport, energy monitoring, computer networks, IoT, energy efficiency.*

**Introduction.** The current stage of global economic development is characterized by fundamental, tectonic changes in approaches to the use and management of energy resources. In the context of the global energy crisis, critical instability of hydrocarbon markets, and the inevitable necessity of implementing international sustainable development strategies, energy efficiency issues are transforming from a purely economic plane into the plane of national security and strategic stability of the state. For railway transport, which is not only the circulatory system of the economy but also one of the largest industrial consumers of electricity, these challenges are particularly acute and urgent [1]. In the structure of railway operating costs, the share of expenses on fuel and energy resources consistently occupies leading positions, often exceeding 15-20%, and even a seemingly minor reduction in specific energy consumption for train traction on the scale of the entire network can yield a colossal multiplicative economic effect measured in billions of currency units.

At the same time, the world stands on the threshold of the Fourth Industrial Revolution (Industry 4.0), the key technological drivers of which are pervasive digitalization, the Internet of Things (IoT), cloud computing, Big Data, and artificial intelligence [2]. These breakthrough technologies are radically changing the very paradigm of managing complex technical systems, which undoubtedly includes the railway power supply system. While throughout the 20th century, increasing the efficiency of traction power supply systems was achieved primarily through extensive modernization of power

equipment - installing more powerful transformers, more economical semiconductor converters, reducing active resistance in the contact network and rail circuits - today this path has practically exhausted its innovation potential. Modern power plants and electric machines have already reached an efficiency level close to the maximum physically possible limit, so the further struggle for energy efficiency is moving to another plane.

Consequently, the center of gravity in energy saving issues is shifting to the information plane. The efficiency of energy management today depends not so much on "hardware" as on "software" on how quickly, accurately, completely, and synchronously we receive information about the processes of energy generation, distribution, and consumption [3]. The problem lies in the fact that the existing railway information infrastructure, designed decades ago, remains quite conservative and inertial. Traditional Supervisory Control and Data Acquisition (SCADA) and Automated Meter Reading (AMR) systems often function as isolated "information silos." They cope excellently with the tasks of recording the total volume of consumed energy for fiscal settlements or emergency shutdown of protection lines but prove absolutely powerless before the tasks of deep analytics, searching for hidden anomalies, and operational adaptive management in real time.

The lack of a single, integrated information space leads to a paradoxical situation where power engineers see only the consequences (load peaks, non-normative losses, equipment overheating) but do not have the tools to instantly identify the causes, which often lie in the technology of the transportation process (schedule violations, irrational train weight, incorrect driver's driving style). In conditions where electric rolling stock is a highly dynamic, fast-changing load, traditional discrete metering systems with a polling interval of 30-60 minutes are practically "blind" to real energy exchange processes. Therefore, an urgent scientific task becomes not just installing new meters, but developing conceptual principles for building a holistic intelligent computer network. Such a network should become the "digital nervous system" of the railway, enabling the transition to the Smart Grid paradigm by ensuring total monitoring of energy costs with high sampling rates and creating the necessary technological base for the implementation of future systems for mathematical optimization of power supply modes [4].

Analysis of recent research and problem statement. A detailed and comprehensive analysis of modern scientific and technical literature, as well as a critical review of advanced global practices, indicate a significant and constantly growing interest of both the scientific community and practicing engineers in the problems of building next-generation intelligent energy networks (Smart Grids). The Smart Grid concept, which implies deep, end-to-end integration of modern information and communication technologies directly into the physical processes of electricity generation, distribution, and consumption, has already proven its undeniable effectiveness in the utility energy sector of many developed countries worldwide [5]. Numerous theoretical and applied studies convincingly demonstrate that the introduction of Smart Metering systems and adaptive Demand Response algorithms allows reducing total technical and commercial electricity losses by 10-15%, optimizing daily load schedules by shaving consumption peaks, and significantly improving the general reliability of power supply through the use of predictive power equipment diagnostics methods [6]. However, despite the obvious and documented successes in general energy, the direct and mechanical adaptation of these typical solutions for the specific needs of railway transport proves impossible or extremely ineffective due to the unique technological specifics of the transport industry, which requires the development of fundamentally new, specialized approaches.

The key problem complicating the transfer of Smart Grid experience to railways lies in the fundamental differences between stationary consumers in the utility sector and highly dynamic active consumers in the transport sector. Firstly, the main energy consumers on the railway electric rolling stock are non-stationary objects moving in space at high speeds, constantly and chaotically passing from one feeder zone to another, which creates a non-trivial task of dynamic consumer identification and correct allocation of energy costs in real-time mode [7]. Secondly, the load of traction networks has a clearly expressed stochastic, sharply variable character, where instantaneous power can change from zero values to maximum in a matter of seconds (for example, during the simultaneous starting of several heavy freight trains), which makes standard data averaging methods and the use of typical load profiles absolutely unacceptable for precise control [8].

Existing automated systems, such as AMR (Automated Meter Reading) and SCADA (Supervisory Control and Data Acquisition), on domestic railways function mainly as isolated, technically and informationally disparate "islands" [9]. SCADA systems were traditionally designed and oriented exclusively towards ensuring train traffic safety, operational switching of disconnectors, and rapid protection of the contact network against short-circuit currents, effectively ignoring tasks of energy efficiency and economic optimization. In turn, AMR systems focus primarily on fiscal functions, recording only integral energy consumption indicators over long periods (month, day, or hour), which makes detailed analysis of instantaneous operating modes and detection of short-term anomalies impossible. Such architectural disunity leads to energy data existing separately from data on technological processes.

Particularly acute and critical is the problem of the deep information gap between power supply services and transportation organization services. Information on the actual train schedule, the exact weight of freight trains, the presence of speed restriction warnings, and the complex track profile resides in some departmental databases, while telemetry information on currents, voltages, power flows, and the status of power equipment accumulates in completely different, often software-incompatible systems [10]. The lack of configured automated, time-synchronized data exchange between these functional domains prevents identifying the true causal relationships of energy costs and reasonably answering the question of why exactly an overload occurred at a specific moment on a specific section or why specific energy consumption for traction exceeded the approved norm. Considering the above, there is an urgent scientific and practical need to form a holistic concept and develop the architecture of a specialized intelligent computer network. The research task lies not just in modernizing individual metering nodes or replacing meters, but in creating a single convergent ecosystem for collecting, transmitting, and processing Big Data that would meet modern stringent requirements for reliability, speed, scalability, and cybersecurity in the conditions of the state's critical infrastructure functioning [11].

**The purpose and tasks of the study.** The main goal of this study is to develop, theoretically substantiate, and systematize the conceptual principles of building an intelligent computer network for monitoring railway energy consumption. This network is positioned as the core information infrastructure required to adapt the Smart Grid concept to the specific conditions of railway transport. Unlike existing analogues, it will ensure deep cross-integration of technological data of the transportation process and power supply parameters, thereby creating the necessary foundation for improving the energy efficiency and reliability of railway transport in the context of digital transformation [12]. Achieving this goal requires the consistent and comprehensive solution of a number of interconnected scientific and practical tasks covering both hardware and software-algorithmic aspects of network construction.

The first task is to conduct a detailed structural-functional analysis of existing information flows in traction and non-traction railway power supply systems. It is necessary to identify their architectural shortcomings, hidden "bottlenecks," data transmission delay factors, and reasons for the informational isolation of subsystems that hinder the implementation of modern energy management methods. This stage involves a critical assessment of the capabilities of existing equipment and the identification of barriers to its integration into a single digital space.

The second task is to develop a multi-level hierarchical architecture of the intelligent network, with a clear definition of the functional purpose, interfaces, and interaction protocols for each level: from the level of physical sensors, transducers, and actuators (Perception Layer) to the level of communications and data transport (Network Layer) and, finally, the level of cloud computing, analytics, and decision-making (Application Layer). The architecture must be flexible, modular, and open for further scaling. The third task is the scientific substantiation of the choice of optimal data transmission technologies for building a reliable heterogeneous communication environment. It is necessary to take into account the specific, often extreme limitations of railway transport, such as the significant linear extent of infrastructure objects, complex terrain, high mobility of subscribers (trains), and the presence of powerful electromagnetic interference from the traction network, which can significantly affect the quality of wireless communication.

The fourth task is to formulate methodological principles for integrating heterogeneous databases in a single information space. This requires determining algorithms for preprocessing "raw" data, methods for synchronizing time series from different sources (for example, superimposing a power profile on a traffic schedule), and approaches to correlation analysis, which will allow identifying non-obvious dependencies between operating modes and energy consumption.

The fifth task is to determine comprehensive requirements for the information security (cybersecurity) of the proposed network. Since the power supply system is part of the state's critical infrastructure, it is necessary to develop strategies for protecting communication channels from unauthorized access, ensuring the integrity and authenticity of telemetry data, as well as the network's resilience to cyberattacks and software failures.

**Materials and methods of research.** The methodological basis of this study is a comprehensive systems approach to analyzing energy exchange processes in heterogeneous transport systems. Traditional methods of researching railway power supply often consider the traction network as a separate electrotechnical system, the parameters of which depend on the load modeled as a random process. In this paper, a fundamentally different approach is applied: the power supply system is considered as an integral part of a Cyber-Physical System (CPS), in which the physical processes of transmission and conversion of electrical energy are inextricably linked with information processes of control, computing, and communication [4]. To develop the conceptual principles for building an intelligent network, a synthesis of fundamental provisions of information systems theory, automatic control theory, principles of building distributed computing networks, and reference models of the Internet of Things (IoT) was used [2]. In particular, the structural-functional modeling method was applied to formalize the architecture of the proposed network, which allowed decomposing a complex system into separate functional levels (perception, network, application) and clearly defining interaction interfaces between them. The comparative analysis method was used to compare the effectiveness of traditional hierarchical centralized control systems (SCADA) and modern decentralized approaches (Edge Computing), which allowed substantiating the feasibility of transferring part of the computing power to the network periphery. Additionally, the information flow simulation modeling method was utilized to estimate the required bandwidth of communication channels under peak load conditions, when telemetry data from dozens of locomotives and substations are transmitted simultaneously.

Characteristics of the empirical basis and analysis of regulatory support. As materials for the research, a significant array of technical documentation and legal acts regulating the operation of existing dispatching and metering systems in railway transport was analyzed. Statistical data regarding the load schedules of DC and AC traction substations were subjected to critical rethinking. The analysis of daily and monthly load profiles revealed high stochasticity of consumption processes, where peak power values can exceed averages by 3-4 times. This served as the basis for the conclusion about the insufficiency of existing measurement sampling intervals (30 minutes) for operational control purposes. International standards of the IEC 61850 series ("Communication networks and systems for power utility automation"), which define modern data exchange protocols in digital energy, were also analyzed [13]. Based on this analysis, requirements for equipment compatibility within the proposed intelligent network were formulated. Special attention was paid to studying the characteristics of modern telecommunications equipment capable of operating in harsh conditions of electromagnetic interference, vibrations, and temperature changes characteristic of railway infrastructure [14].

Method of building the Perception Layer architecture. The developed methodology for building the lower level of the network is based on the concept of "sensor saturation." Unlike existing systems, where metering points are only the inputs of traction substations, the proposed method involves the total digitalization of all active system elements. For stationary objects (traction substations, sectioning posts, parallel connection points), the use of Intelligent Electronic Devices (IEDs) is substantiated. The methodology involves installing IEDs on each feeder of the contact network. A key requirement is a high signal sampling rate, which allows recording not only effective values of current and voltage but also power quality parameters: the voltage waveform distortion factor, the level of higher harmonics, and phase asymmetry [15]. This allows diagnosing the condition of rectifier units and detecting

precursors of emergency modes. For mobile objects (electric rolling stock), a dynamic energy metering method has been developed. It is based on the continuous recording of three energy vectors: energy consumed for traction; energy returned to the contact network in regenerative braking mode; energy spent on the locomotive's auxiliary needs (compressors, fans, heating). A critically important element of the methodology is the synchronization of measurements with spatiotemporal coordinates. Each data packet is marked with an exact timestamp and geolocation data (GPS/GNSS coordinates), which allows linking consumption to a specific point of the track profile [16].

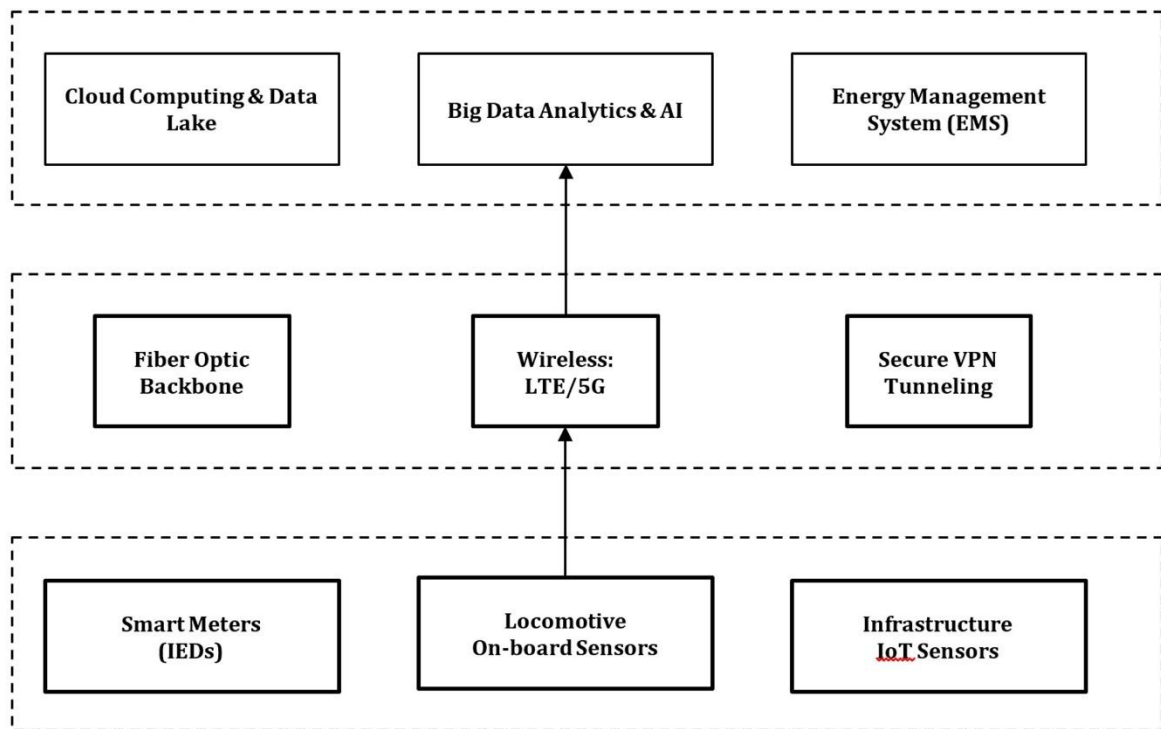

*Fig. 1. Three-level architecture of the intelligent railway energy monitoring network*

Substantiation of the choice of Network Layer technologies. Building a reliable data transmission system under conditions of significant linear extent of railway infrastructure (thousands of kilometers) requires the use of a hybrid communication model. The study analyzed available communication technologies based on criteria of bandwidth, latency, reliability, and implementation cost. For backbone communication channels between stationary objects, the lack of alternatives to using fiber-optic communication lines (FOCL) with Dense Wavelength Division Multiplexing (DWDM) technology is substantiated. This ensures gigabit data transmission speeds required for aggregating streams from thousands of sensors and complete immunity to electromagnetic fields of the traction network [13]. To organize the "last mile" communication with moving objects, the efficiency of GSM-R, LTE-R, and 5G standards was analyzed. It was established that the existing GSM-R standard is unable to provide the necessary data transmission speed for real-time monitoring tasks. Therefore, a transition to broadband LTE-R (Long Term Evolution for Railways) technologies or prospective 5G networks is proposed, which support a stable connection at train speeds up to 300-350 km/h, neutralizing the Doppler effect [17].

For collecting data from autonomous infrastructure sensors (wire temperature, insulator condition) powered by batteries, a method of using energy-efficient long-range networks LPWAN (Low Power Wide Area Network), in particular LoRaWAN technology, is proposed. This allows deploying a dense network of sensors with minimal maintenance costs since the battery life can reach 5-10 years.

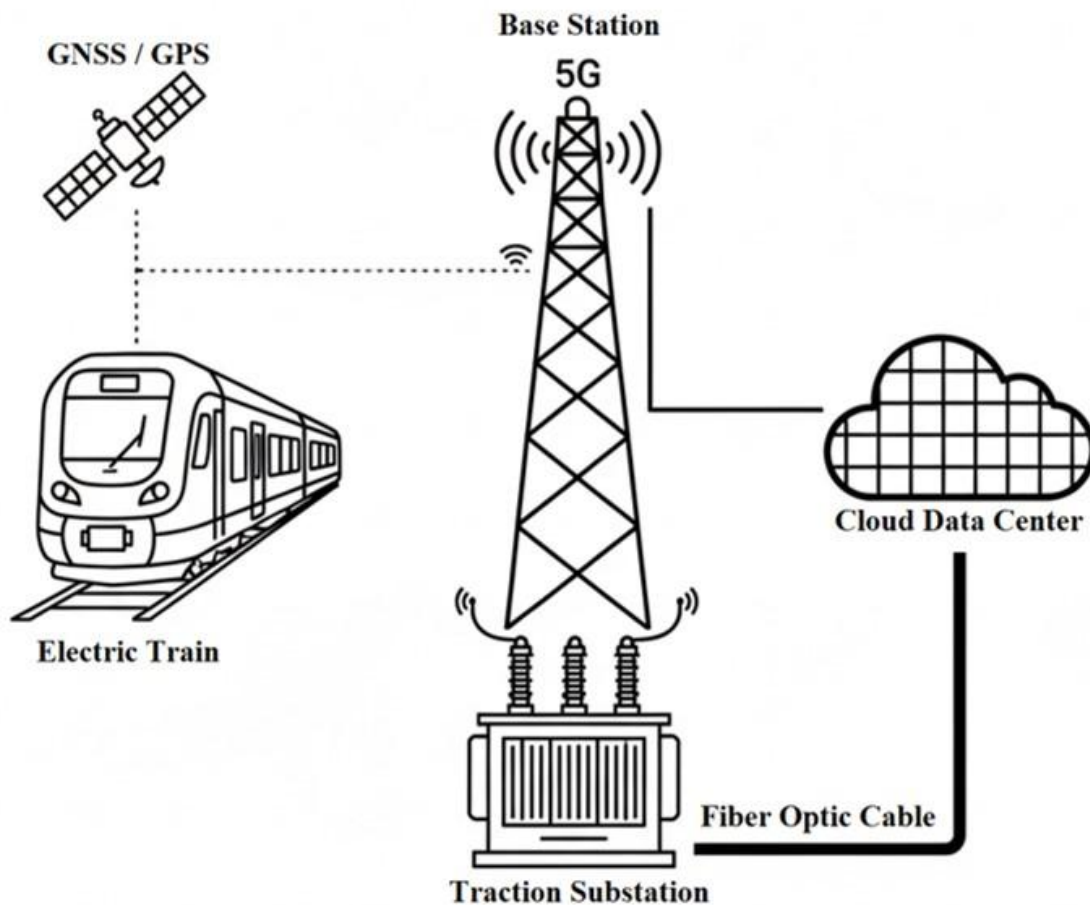

**Fig. 2. Structural diagram of the hybrid communication system for mobile and stationary objects**

Data processing and intellectualization methodology. The methodology for processing the obtained information arrays is based on the use of cloud technologies and Big Data architecture. Instead of traditional relational databases, the use of specialized Time-Series Databases, optimized for fast writing and reading of chronologically ordered metrics, is proposed.

A separate, critically important stage of the research involves the development of algorithmic support for synchronizing heterogeneous data streams, which is a fundamental challenge in distributed monitoring systems. Since telemetry data originates from diverse sources - stationary smart meters at substations, mobile sensors on rapidly moving locomotives, and external meteorological services these data streams possess different sampling rates and latency characteristics. To address this, a comprehensive Data Pre-processing method is proposed. This method includes multi-stage filtration to remove noise and artifacts caused by electromagnetic interference, reconstruction of missing values using linear interpolation algorithms, and normalization of timestamps to a unified standard.

To ensure the high precision of event synchronization across the distributed network, the use of the Precision Time Protocol (PTP, IEEE 1588v2) is substantiated. Unlike the standard Network Time Protocol (NTP), which provides millisecond-level accuracy, PTP ensures sub-microsecond accuracy by using hardware timestamping at the physical layer of the network interface. This level of precision is mandatory for correctly correlating instantaneous current values measured at the electric train pantograph with the corresponding values recorded at the substation feeder, thereby neutralizing the impact of stochastic delays (jitter) in data transmission channels.

At the application logic level, an advanced Anomaly Detection model based on comparative analysis has been developed. The system automatically constructs a specific "energy passport" for each trip in real-time, comparing the actual energy consumption with a theoretically calculated reference model. This reference model is dynamically generated by solving the differential equation of train motion, taking into account variable parameters such as the track profile (gradients, curves), the actual weight of the train, aerodynamic resistance, and the specific efficiency curve of the locomotive type. If the deviation of the actual consumption from the reference value exceeds a predefined threshold (e.g., 5-7%), the system triggers an automated incident report for further investigation. This approach allows for the detection of not only technical malfunctions, such as increased motion resistance due to chassis defects or brake system drag, but also organizational shortcomings, specifically violations of energy-efficient driving mode maps by locomotive crews. A key element of the methodology is the developed algorithm for cross-correlation of energy and logistics data. The essence of the method lies in the automatic superimposition of the electricity consumption schedule on the executed train traffic schedule. The system analyzes the deviation of actual consumption from the reference profile calculated based on traction calculations for a specific locomotive series, train weight, and track section. This allows separating technologically justified energy costs from unproductive losses caused by equipment malfunction or irrational actions of the driver [10]. The methodology also includes the application of Machine Learning methods for implementing predictive analytics [18]. Based on historical consumption data, the planned traffic schedule, and weather forecasts, a neural network builds a load forecast for traction substations with a planning horizon from 1 hour to 1 day. This enables dispatching personnel to optimize the power supply scheme in advance, for example, by switching backup transformers on or off to reduce no-load losses [19].

To solve the problem of latency and reduce the load on backbone communication channels, the architecture provides for the implementation of the Fog Computing paradigm. Unlike the classic cloud model, where all data is transmitted to a central server for processing, Fog Computing involves the deployment of an intermediate layer of computing nodes directly at the level of traction substations or large railway junctions. These "fog" nodes perform primary filtration, aggregation, and compression of telemetry data. For example, raw oscillograms of currents and voltages with a frequency of several kilohertz are processed locally to calculate vector values (Phasors), and only the calculated parameters are transmitted to the cloud with a frequency of 1-10 Hz. This approach reduces traffic volume by 90-95% without losing informational value for the operational dispatcher. Furthermore, particular attention is paid to the optimization of application-layer data transfer protocols. For the segment of interaction with resource-constrained IoT sensors (e.g., battery-powered temperature sensors on catenary supports), the use of the CoAP (Constrained Application Protocol) or MQTT-SN (Message Queuing Telemetry Transport for Sensor Networks) is substantiated. These protocols operate over UDP and have a significantly smaller header overhead compared to standard HTTP/TCP, which is critical for low-bandwidth networks such as LoRaWAN. For critical control commands requiring guaranteed delivery (Quality of Service - QoS), the system utilizes the priority tagging mechanism (VLAN 802.1p), ensuring that technological traffic is processed by network switches with higher priority than diagnostic or video surveillance data.

Methods of ensuring information security and reliability. Since the railway power supply system belongs to critical infrastructure facilities, the research methodology includes the development of a set of cybersecurity measures. The necessity of physical and logical separation of the technological monitoring network and public networks is substantiated. The use of tunneling methods (VPN), traffic encryption using TLS 1.3 protocols, and the implementation of Public Key Infrastructure (PKI) for authenticating each device in the network is proposed.

Considering the exponential growth of cyber threats targeting critical infrastructure facilities, the paper details a robust architecture for the information security subsystem based on the "Defense in Depth" paradigm. This approach implies a multi-layered security strategy that covers physical, network, and application levels. At the level of peripheral devices (Edge), hardware-based authentication of sensors is implemented using Trusted Platform Modules (TPM) and cryptographic chips. This measure

effectively prevents "Device Spoofing" attacks, where an attacker attempts to emulate a legitimate sensor to inject false data into the system.

At the network level, strict traffic segmentation is applied through the implementation of Virtual Local Area Networks (VLANs). Technological data traffic is logically isolated from the corporate office network and the public Internet, creating a demilitarized zone (DMZ) for external connections. Furthermore, the deployment of industrial-grade Intrusion Detection and Prevention Systems (IDS/IPS) is substantiated. These systems are specifically configured to perform Deep Packet Inspection (DPI) of industrial protocols such as IEC 60870-5-104, DNP3, or Modbus TCP. This capability allows the system to detect and block anomalous control commands or malformed packets that may indicate a sophisticated cyberattack attempt, such as a Man-in-the-Middle (MitM) attack or a Denial of Service (DoS) aimed at disrupting energy monitoring operations. Additionally, regular automated vulnerability scanning and penetration testing are recommended as part of the security lifecycle management. To ensure the integrity of commercial metering data, the possibility of using distributed ledger technology (Blockchain) is considered, which makes unauthorized modification of archival data impossible [8]. To increase network reliability, structural and informational redundancy methods were applied. In particular, duplication of communication channels and the creation of backup data processing centers with automatic information replication are provided.

Evaluation of expected efficiency. The theoretical assessment of the effectiveness of the proposed intelligent network architecture indicates a significant potential for energy saving and operational optimization. Calculation modeling demonstrates that the transition from passive metering to active energy consumption management based on real-time data will allow reducing specific electricity consumption for train traction by approximately 3-5%. This reduction is primarily achieved through the optimization of train driving modes (adhering to energy-optimal velocity profiles) and the minimization of braking losses.

Furthermore, an additional 2-3% reduction in energy losses within the power supply network is expected due to the optimization of power flow distribution and the intelligent management of reactive power compensation devices. On the scale of the entire railway network, these percentage reductions translate into the saving of tens of millions of kilowatt-hours of electricity annually, resulting in a substantial decrease in operational expenses (OPEX).

Beyond the direct economic effect, the implementation of the system will yield a significant positive environmental impact. By reducing overall energy consumption, the indirect emissions of CO<sub>2</sub> and other greenhouse gases associated with electricity generation will be lowered. This contributes to the decarbonization of the transport sector and aligns the railway infrastructure development with the environmental strategies of European integration and the "Green Deal" initiatives. The system also facilitates the transition from a rigid system of planned preventive repairs to a flexible Condition-Based Maintenance (CBM) strategy, extending the service life of traction transformers and contact network components by monitoring their actual thermal and electrical loads.

Integration with renewable energy sources and storage systems. The proposed intelligent network concept lays the foundation for the transformation of the railway power supply system into an active grid with distributed generation. The architecture provides for the seamless integration of renewable energy sources (RES), such as solar power plants installed on the roofs of station buildings or noise barriers, as well as wind turbines located in the railway right-of-way. The intelligent monitoring system allows for real-time balancing of generation from RES and consumption by traction loads, directing surplus energy to charge stationary Energy Storage Systems (ESS) based on lithium-ion or supercapacitor batteries. The integration of ESS is particularly effective for stabilizing voltage in the catenary network on remote sections and for utilizing excess recuperation energy that cannot be absorbed by other trains or returned to the external grid due to inverter limitations. The developed algorithms for the "Energy Management System" (EMS) module allow controlling the charge/discharge cycles of storage devices based on the current tariff policy (charging at night at a low rate and discharging during peak hours), which ensures additional economic benefits and reduces peak demand charges from the external grid operator. Thus, the railway transforms from a passive consumer into a

"prosumer" (producer-consumer), actively participating in the regional energy market and providing demand response services.

**Conclusions.** In the presented scientific work, the urgent scientific and practical task consisting in the development, theoretical substantiation, and systematization of the conceptual principles of building intelligent computer networks for monitoring, analyzing, and optimizing energy consumption in railway transport is solved. The conducted research allowed formulating a number of important conclusions that have both theoretical and applied significance for the further development of the industry's digital infrastructure. Firstly, a detailed and critical analysis of the current state of information support for the railway energy economy revealed significant systemic shortcomings that hinder energy efficiency improvements. It was established that traditional automated systems (SCADA, AMR) function as isolated information domains, operating with data of low time discretization and a complete lack of mutual synchronization with transportation management systems. Such architectural disunity makes it impossible to implement adaptive algorithms for energy consumption control in real-time and creates information barriers to identifying and localizing unproductive energy losses.

Secondly, a three-level intelligent monitoring network architecture has been developed and structurally formalized, based on the principles of building distributed cyber-physical systems and including the Perception Layer, Network Layer, and Data Processing Layer. The proposed architecture ensures complete digital transparency of energy exchange processes at all stages of energy transformation - from the traction substation input to the electric train pantograph. A distinctive feature and element of scientific novelty of the developed concept is the integration of rolling stock as an active, mobile element of the Internet of Things (IoT) network. This allows continuous monitoring of energy recuperation efficiency and assessing the energy efficiency of train driving modes with precise reference to geographical coordinates and the track profile.

Thirdly, the choice of optimal data transmission technologies for building a reliable heterogeneous communication environment is scientifically substantiated. It is determined that under the specific and harsh conditions of railway transport (significant linear extent, powerful electromagnetic interference, high subscriber mobility), a hybrid model is required. It must combine high-speed fiber-optic backbones for stationary infrastructure objects and secure broadband wireless networks of LTE-R or prospective 5G standards for mobile objects. This approach allows minimizing packet transmission latency, ensuring guaranteed delivery of critically important telemetry data, and creating the necessary bandwidth reserve for future services.

Fourthly, a new methodological approach to integrating heterogeneous databases - energy and logistics - in a single cloud information space is proposed. Synchronization of electrical load schedules with executed train traffic schedules creates the necessary basis for implementing predictive analytics and machine learning algorithms, as well as for creating a "Digital Twin" of the power supply system. This allows moving from reactive incident response to proactive management, forecasting peak loads, and optimizing power supply schemes in advance. The practical value of the work lies in creating a technological foundation for the transition from a system of planned preventive repairs to Condition-Based Maintenance.

Summarizing the results, it can be stated that the implementation of the developed intelligent computer network architecture is a necessary technological prerequisite for the transformation of railway transport to the Smart Grid model.

This will create a reliable basis for further scientific research in the direction of developing mathematical models for optimizing power supply modes, which in the future will ensure a significant reduction in operating costs, an increase in transportation reliability, and contribute to the decarbonization of the transport sector.

## REFERENCES

1. Kornienko, V. (2021). Conceptual bases of digitalization of railway transport of Ukraine. *Rail Transport of Ukraine*, 3, 14-22. [in Ukrainian].
2. Al-Fuqaha, A., Guizani, M., Mohammadi, M., Aledhari, M., & Ayyash, M. (2015). Internet of things: A survey on enabling technologies, protocols, and applications. *IEEE Communications Surveys & Tutorials*, 17(4), 2347–2376. <https://doi.org/10.1109/COMST.2015.2444095>.
3. Ocheretianyi, T., & Vlasenko, O. (2022). Monitoring systems in railway transport. *Journal of Railway Engineering*, 14(2), 45-52. <https://doi.org/10.32703/2617-9040-2022-39-5>.
4. Fraga-Lamas, P., Fernández-Caramés, T. M., & Castedo, L. (2017). Towards the Internet of Smart Trains: A Review on Industrial IoT-Connected Railways. *Sensors*, 17(6), 1457. <https://doi.org/10.3390/s17061457>.
5. Sababan, A., & Alsharif, M. H. (2018). Smart Grid Technologies: A Review. *International Journal of Advanced Science and Technology*, 119, 39–50. <https://doi.org/10.14257/ijast.2018.119.04>.
6. Siano, P. (2014). Demand response and smart grids - A survey. *Renewable and Sustainable Energy Reviews*, 30, 461–478. <https://doi.org/10.1016/j.rser.2013.10.022>.
7. Myamlin, S., Lingaitis, L. P., Dailydka, S., Vaičiūnas, G., & Bogdevičius, P. (2019). Experimental research of electric power consumption by electric rolling stock. *Transport Problems*, 14(1), 117-128. <https://doi.org/10.20858/tp.2019.14.1.11>.
8. Popescu, M., & Bitoleanu, A. (2019). A review of the energy efficiency improvement in DC railway systems. *Energies*, 12(6), 1092. <https://doi.org/10.3390/en12061092>.
9. Bosyi, D., Sychenko, V., & Kosariev, Y. (2021). Intellectual system of electricity metering on DC electric traction. *Naukovyi Visnyk Natsionalnoho Hirnychoho Universytetu*, (3), 85-90. <https://doi.org/10.33271/nvngu/2021-3/085>.
10. Li, L., & Wang, X. (2018). Technology and application of railway energy management system. *China Railway*, 6, 78-82.
11. Gonzo, M. (2023). Cybersecurity in Railway Signaling Systems. *Transport Systems and Technologies*, 21(1), 12-19. <https://doi.org/10.17816/transsyst202321112-19>.
12. Butkevych, O., Zaitsev, I., & Cherevko, O. (2020). Problems of integration of renewable energy sources into the unified energy system of Ukraine. *Technical Electrodynamics*, (4), 56-62. <https://doi.org/10.15407/techned2020.04.056>.
13. Gungor, V. C., Sahin, D., Kocak, T., Ergut, S., Buccella, C., Cecati, C., & Hancke, G. P. (2011). Smart grid technologies: Communication technologies and standards. *IEEE Transactions on Industrial Informatics*, 7(4), 529-539. <https://doi.org/10.1109/TII.2011.2166794>.
14. Sychenko, V., & Kosariev, Y. (2020). Electromagnetic compatibility and power quality in railway power supply systems. *Dnipro National University of Railway Transport named after Academician V. Lazaryan*. [in Ukrainian].
15. Douglas, H., Schmid, F., Roberts, C., & Hillmansen, S. (2016, August). Evaluation of permanent magnet motor energy saving technology for different types of railways. In *2016 IEEE International Conference on Intelligent Rail Transportation (ICIRT)* (pp. 123-129). IEEE. <https://doi.org/10.1109/ICIRT.2016.7588721>.
16. Zhao, N., Roberts, C., & Hillmansen, S. (2021). A Review of On-Board Energy Storage Systems for Railway Traction. *Energies*, 14(12), 3581. <https://doi.org/10.3390/en14123581>.
17. Balador, A., Koukoutsidis, I., & Ciubotaru, B. (2018). Wireless Onboard-Offboard Communication in Railways: Architecture and Challenges. *Wireless Personal Communications*, 102, 2139-2156. <https://doi.org/10.1007/s11277-018-5253-x>.
18. Mohandu, A., & Kubendiran, M. (2021). Survey on big data techniques in intelligent transportation system (ITS). *Materials Today: Proceedings*, 47, 8-17. <https://doi.org/10.1016/j.matpr.2021.03.479>.
19. Wu, Y., Yan, L., Li, W., & Li, Z. (2020). Energy Management Strategies for Smart Railway Stations Integrating Renewable Energy and Energy Storage. *IEEE Access*, 8, 162367-162379. <https://doi.org/10.1109/ACCESS.2020.3021022>.

**Данак Олексій\*<sup>1</sup>**

<sup>1</sup>Аспірант кафедри автоматизації та комп'ютерно-інтегрованих транспортних технологій Національний транспортний університет, вул. Михайла Омеляновича-Павленка, 2, 01010, м. Київ, Україна. ORCID: <https://orcid.org/0009-0000-3595-9391>.

### **Концептуальні засади побудови інтелектуальних комп'ютерних мереж для моніторингу енерговитрат залізниць**

**Анотація.** У статті розроблено та обґрунтовано концептуальні засади побудови інтелектуальних комп'ютерних мереж для моніторингу енерговитрат на залізничному транспорті в умовах цифрової трансформації галузі. Проведено критичний аналіз існуючих систем обліку електроенергії, виявлено їхню функціональну обмеженість, яка полягає у дискретності вимірювань, відсутності єдиного інформаційного простору та неможливості зіставлення енергетичних параметрів із технологічними показниками перевізного процесу в режимі реального часу. Запропоновано нову архітектуру системи моніторингу, що базується на принципах Smart Grid та технологіях Інтернету речей (IoT). Детально описано трірівневу модель мережі: рівень сприйняття (Smart-сенсори та бортові системи локомотивів), комунікаційний рівень (гетерогенні канали зв'язку) та рівень інтелектуальної обробки даних (хмарні та туманні обчислення). Окрему увагу приділено питанням кібербезпеки та захисту критичної інфраструктури при передачі даних, а також методології синхронізації часових рядів енергоспоживання з графіком руху поїздів. Визначено, що впровадження запропонованої концепції дозволить перейти від пасивної констатації витрат до активного енергоменеджменту, що є необхідною передумовою для подальшої математичної оптимізації режимів електропостачання.

**Ключові слова:** інтелектуальні мережі, Smart Grid, залізничний транспорт, енергомоніторинг, Інтернет речей (IoT), енергоефективність, цифрова трансформація, кібербезпека.

Дата першого надходження статті до видання 21.09.2025

Дата прийняття до друку статті 25.11.2025

УДК 621.3

Ya. Shostak<sup>1\*</sup>, Yu. Reshetnikov<sup>2</sup>

<sup>1</sup>Postgraduate student of the Department of Electromechanics and Railway Rolling Stock, National Transport University, 1 Omelyanovycha-Pavlenka St., Kyiv. 01010. Ukraine. ORCID: <https://orcid.org/0009-0006-2886-3264>.

<sup>2</sup>Asistent of the Department of Electromechanics and Railway Rolling Stock, National Transport University, 1 Omelyanovycha-Pavlenka St., Kyiv. 01010. Ukraine. ORCID: <https://orcid.org/0009-0009-3893-1736>.

\*Corresponding author: [shostakzerz@gmail.com](mailto:shostakzerz@gmail.com).

### Improvement of the impregnation technology of traction motor windings in order to improve the parameters of rotor imbalance

*The work is devoted to improving the quality indicators of balancing rotors of electric machines by technological methods on the example of overhaul of traction electric motors of electric trains of series EP2, EP9, EPL2, EPL9, ED9 at PrJSC "Kyiv Electric Wagon Repair Plant". The features of the technological process of eliminating mechanical imbalance of rotors during the manufacture and repair of electric motors are analyzed. The causes of mechanical imbalance of rotors are clarified. The degree of influence on the imbalance of rotors of uneven distribution of impregnation compound over the volume of electrical windings is experimentally investigated. The hypothesis put forward about the possibility of partial compensation of static imbalance of rotors by controlling the distribution of the compound during application of electrical insulation (impregnation) of windings is confirmed. A method of controlling the distribution of the compound during impregnation is proposed. The essence of the method is to fix the rotor in the drying chamber in a position corresponding to the phase angle of the "heavy spot", namely by placing it with the "heavy spot" up. Controlling the distribution of the compound over the rotor volume can be considered as a technological method for improving balancing performance. The method makes it possible to improve the quality of balancing by reducing the mass of balancing loads during the final balancing of rotors by up to 70%.*

**Keywords:** railway transport, wagons, electric train, rotor balancing, traction electric motors, electrical insulation of windings, impregnation of windings.

**Introduction.** A characteristic feature of the technological process of manufacturing and repairing electric motors is the need to eliminate mechanical imbalance of the rotor in the last technological operations. Such operations are operations related to the impregnation of electrical windings with a special insulating varnish – compound.

The cause of the imbalance may be deviations in the installation of the armature components: shaft, core plates, windings, collector components, etc. Another factor affecting the rotor imbalance is the uneven distribution of the compound over the volume during winding impregnation. The mass of the compound for impregnating the rotors of an electric motor can be up to 3% of the mass of the rotor itself [1]. The distribution of the compound over the rotor can be significantly uneven [2]. In this regard, the idea of controlling the distribution of the compound during the impregnation of the armature windings to improve its mechanical balancing characteristics seems attractive.

**Analysis of recent research and problem statement.** In the article [3], the thermal and electrical characteristics of polyester resins for impregnation of electric motor insulation are considered. The task

of the work is to determine which of the resins can best perform the function of insulation of powerful electric motors with inverter power supply with wide-pulse modulation. Several resin formulations with different viscosity characteristics are considered. The results obtained confirm the importance of choosing the optimal viscosity of impregnating resins for reliable insulation of electric motor rotors.

In the paper [4] the requirements for rotors of powerful high-speed electric motors are analyzed. In particular, it is stated that the requirements for the minimum initial unbalance and the change in unbalance during operation can be a problem in operation. It is emphasized that for economically viable and resource-saving production of high-efficiency motors, solutions are needed to reduce unbalance. An overview of technical problems and potential solutions for reducing unbalance in the production and repair of rotors of rotating electrical machines is presented.

A thorough analysis of the causes of unbalance in rotors of electrical machines is presented in the article [5]. It is emphasized that the most common malfunction of electrical machines is residual unbalance of rotors. The causes of unbalance are analyzed: manufacturing errors; anisotropy of material properties; thermal deformation; wear during operation; structural changes in electrical insulation.

The modern approach to diagnosing unbalance is based on the latest system of technical maintenance (TM) of electrical machines. In this case, the corrective TM system is replaced by a preventive system of operational monitoring of the electric motor [6]. The advantage of internal diagnostic systems is substantiated, which allows detecting malfunctions during operation at an early stage based on vibration analysis. The possibility of reducing costs associated with electric motor failures is attractive. The results of work [6] allow to systematize the causes of rotor imbalance and obtain promising directions for improving the parameters of rotor balancing of electric machines.

Based on the statistical analysis of the operation of asynchronous electric motors, the most frequent cause of electric motor failures was found out in work [7]. Such a cause is considered to be the presence of an imbalance acquired during operation. Imbalance can be the cause of significant vibrations of engine elements, which in turn can lead to their breakdown. It is argued that the vibration response can provide information about existing engine defects directly in the mode of its operation without stopping it. The prospects of the method of diagnosing defects in electric motors based on vibration analysis are substantiated.

In article [8], the issues of increasing the reliability of electric machines of traction rolling stock using local methods of strengthening electrical insulation are considered. The method of infrared radiation during the production and repair of traction electric motors of electric locomotives is considered. The reasons for the low reliability of collector electric motors are analyzed. It is argued that the low reliability of electrical machines is associated with the limited life of winding insulation. Existing insulation restoration methods are not able to properly ensure high-quality insulation strengthening during depot and factory repairs.

The article [9] is devoted to the analysis of the thermal regime of heating and cooling of electrical machine windings. The heat exchange between copper conductors, core, housing and air is studied. Cases of winding overheating and its effect on aging and structural changes in electrical insulation are considered. The article contains a review of research on technologies that contribute to winding cooling, such as winding topology with more effective heat dissipation, impregnating material with high thermal conductivity and improved direct winding. Cooling control methods are considered and classified, and recommendations are given for the design of high-torque electrical machines for better winding cooling.

The study [10] is devoted to improving the quality of impregnation of stator windings of an electric motor. Attention is drawn to the fact that the reliability of electric motors depends on the insulation of the windings, which is determined by the quality of the materials used and the impregnation technology. Impregnation of electric windings is an important technological process for ensuring the durability of electric motors. As a result of impregnation, the air pores between the windings and the gaps in the fiber insulation are filled with a compound, which ensures reliable fixation of the windings. There are various methods that ensure effective filling of pores and cavities with a compound. The article provides general information about the varnishes used for impregnation of electric motor windings, according to their

composition. The article shows the scheme of stator rotation during the drying process after impregnation. The mechanism of implementation of the proposed method is also given.

The article [11] is devoted to the analysis of the thermal behavior of insulating impregnating materials of electric machines. Attention is drawn to a typical picture of uneven filling of the cavities between the winding elements with a compound. The influence of the impregnation quality on the process of heat removal from the windings is discussed.

The results of a comparative analysis of the thermal properties of electrical windings impregnated with alternative varnish materials are presented in [12]. The impregnation quality coefficient is considered, which allows taking into account the uneven distribution of the compound over the volume of the windings. The experimental results are supplemented by a theoretical analysis of the impregnation quality of the windings.

The article [13] considers methods for optimizing the distribution of unbalance in rotating machines. It is noted that classical methods for balancing rotating machines are based on the assumption of the linearity of the nature of the unbalance. An example of classical balancing methods is a method based on taking into account the influence coefficient. However, if nonlinearity appears in the structure, these methods give errors, and the results obtained regarding the corrective loads and their corresponding angular positions are unsatisfactory. On the other hand, the choice of the number and location of the corrective planes depends on the possible availability, which differs for each machine. In this work, a new method designed to identify rotating machines and distribute the unbalance in linear and nonlinear conditions is implemented using pseudo-random optimization methods. In this case, the system modeling is performed using the well-known finite element method.

In the article [14], the possibility of improving the quality of balancing rotors of traction electric motors of electric trains on stationary balancing machines is considered. According to the traditional balancing technology, the rotor to be balanced is installed on the supports of the balancing machine with support surfaces, which, as a rule, have mechanical defects. These defects, due to the peculiarities of the rotor repair technology, cannot be eliminated by mechanical processing. Theoretical and experimental studies of the influence of damage to the rotor support surfaces on the balancing parameters were carried out. It has been proven that the properties of the rotor support surfaces during its balancing on a balancing machine significantly affect the results of determining the imbalance. In this case, the deviation of the masses of the corrective weights can reach 25%. This is explained by the fact that damage to the rotor support surfaces creates false signals that are not related to the imbalance. To increase the accuracy of determining the mass of the balancing weights during rotor balancing, an improvement of the balancing process is proposed. The improvement consists in including a frequency filter in the acceleration sensor signal conversion circuit. The filter is designed to separate signals with a frequency higher than the rotor speed.

Analysis of known studies allows to conclude that when impregnating electric motor rotors, there is an uneven distribution of the compound over the volume of the windings. Thus, the impregnation operation is an additional factor in the formation of the motor rotor imbalance. The accumulation of the compound on the "heavy" side of the rotor is inevitable if the rotor drying process after impregnation is not corrected. Due to these considerations, a hypothesis was put forward about the possibility of improving the balancing parameters of the rotor of an electric motor by adjusting the winding impregnation operation.

**The aim and objectives of the study.** The aim of the study is to substantiate the feasibility of adjusting the technology of impregnation of the windings of a traction motor in order to improve the rotor balancing parameters.

**Analysis of the unbalance indicators of rotors of electric machines.** Unbalance, as a measure of rotor unbalance, is usually determined by the formula [15]:

$$\bar{d} = m \cdot \bar{r}, \quad (1)$$

where  $m$  – unbalanced mass;

$\vec{r}$  – eccentricity vector – the distance between the center of gravity of the unbalanced mass and the axis of rotation of the rotor.

The imbalance according to formula (1) is an absolute imbalance, which does not give an idea of its level. Sometimes the specific imbalance  $D$  is used, as the ratio of the absolute imbalance to the rotor mass [16]:

$$D = \frac{m \cdot r}{m_r}, \quad (2)$$

where  $m_r$  – the rotor mass.

However, formulas (1) and (2) require the value of the unbalanced mass  $m$ , and the location of its center of gravity. There is no method for determining these parameters. Thus, formulas (1), (2) are purely theoretical.

For a practical assessment of the degree of static imbalance, static imbalance can be used:

$$d_s = m_r \cdot e, \quad (3)$$

where  $e$  – the rotor eccentricity – the distance from the center of gravity of the rotor to the axis of its rotation.

The theoretical provisions regarding dynamic imbalance are mentioned in many studies [17]. Dynamic imbalance is associated with the moment created by reactions in the rotor supports. Dynamic imbalance can be eliminated by changing the location of the supports. Fig. 1 shows a diagram of the forces acting on a rotor with imbalance.

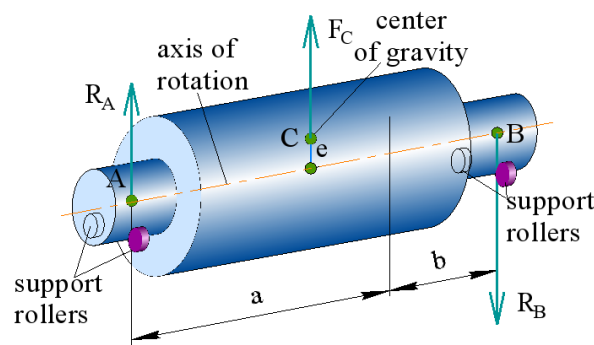

**Fig. 1. Scheme of forces acting on a rotor with imbalance**

Dynamic reactions in the rotor supports associated with the presence of imbalance can be determined by the formulas:

$$R_A = F_C \cdot \frac{a}{a+b}; \quad R_B = F_C \cdot \frac{a}{a+b}, \quad (4)$$

where  $a$  and  $b$  – the distances of the rotor center of gravity from the roller supports.

The condition for the absence of dynamic imbalance can be a symmetrical arrangement of the supports relative to the rotor center of gravity, i.e. when  $a = b$ . Thus, any imbalance can be reduced to static if it is possible to change the position of the rotor supports. However, in practice, as a rule, eliminating dynamic imbalance by changing the position of the supports is not possible.

A feature of the technological process of manufacturing and repairing electric motors is the uneven distribution of the compound over the volume when impregnating the rotor windings. Despite the

insignificant mass of the compound, it is possible to shift the rotor center of gravity relative to the supports by controlling its volume distribution.

**Conditions for conducting the experiment.** The experiment was conducted with two rotors of the 1DT-003 engine (EPL2T electric train). The rotor imbalance was checked twice: before impregnation and after impregnation. The imbalance and balancing parameters were checked on the EI2000 balancing machine (manufacturer "NORMA-UA" – Ukraine). The main technical characteristics of the EI2000 machine are given in Table 1.

*Table 1. Technical characteristics of the EI-2000 balancing machine*

Parameter name	Value
Range of rotor masses to be balanced	10-2000 kg
Maximum rotor diameter	1800 mm
Maximum rotor diameter above the drive	1300 mm
Distance between the centers of the rotor support necks, minimum/maximum	250–3000 mm
Permissible diameters of the rotor support necks	25–225 mm
Range of rotor rotation frequencies	200–1200 <b>rpm</b>
Minimum residual specific unbalance	0,2 g mm/kg
Type of drive motor	Frequency-controlled asynchronous
Power supply network parameters	380±10% V, Ph, 50±1% Hz
Power of the AIR 112M2 electric motor	7,5 kW
Type of rotor rotation transmission	Belt drive
Measuring system	Digivibe MX M10
Floating supports	S/N YBF230103
Control panel	J00496R:2023-PC
Laser phase marker	OP20-5P S/N FOL5212083
Additional devices	USB – interface GX-400 S/N FIGH4211845
Overall dimensions	3150x1500x1500 mm

The balancing machine has the following means of recording and processing experimental data:

- acceleration sensors of the type ADXL202 (Analog Devices);
- analog-to-digital converter of the type KADL-06;
- recording complex with a device for outputting test protocols to the display and in electronic form for downloading.



*Fig. 2. Balancing machine EI2000 with the rotor of the electric motor 1DT-003 installed for balancing*

The test load method (three-start method) was used during balancing. The method involves performing three test starts to determine the dynamic impact coefficient. Input data for the balancing machine: rotor weight, distance between the machine supports.

According to the results of checking the rotor imbalance before impregnation, the phase of the imbalance location was determined and the “heavy spot” was noted by core drilling on the end surface of the shaft.

The technological process of impregnation is analyzed using the example of a major overhaul of traction electric motors at PrJSC “Kyiv Electric Wagon Repair Plant”. The technological process consists of three technological processes (TP): moisture removal, impregnation and drying. Equipment for performing operations - drying cabinet, autoclave, drying oven.

1st TP. Moisture removal is performed to remove moisture from the rotor holes, including capillary holes. Moisture removal takes place in three operations:

- heating in a drying oven to a temperature of 70°C;
- holding at this temperature for four hours;
- cooling to a temperature of 45°C.

2nd TP. Impregnation in an autoclave consists of the following operations:

- placing the heated armature in an autoclave (Fig. 3);
- evacuating the autoclave with a residual pressure of 0.003-0.005 MPa for 30–40 minutes;
- filling the autoclave with an impregnating compound (compound – Elplast 155 ID);
- holding the rotor in an autoclave under a pressure of 0.38–0.4 MPa for 60 minutes;
- draining the compound from the autoclave and reducing the pressure to atmospheric;
- holding the rotor in an autoclave for 30 minutes to drain off any remaining compound.



**Fig. 3. Autoclave for rotor impregnation (a) and drying oven for drying (b)**

3rd TP. Drying the rotor in a drying oven. The impregnated rotor is installed on supports (Fig. 4) in the space of the drying oven, where it warms up. The Elplast-155ID compound acquires the greatest fluidity at a temperature of 60-90 °C, while the viscosity becomes about 30-40 s (conditional viscosity according to the VZ-246 viscometer - 4mm). The gelatinization process occurs at a temperature of 130°C. The drying oven reaches the 130°C mode in 3.5 hours. The total time for warming up and gelatinization usually takes up to 5 hours. By the time the gelatinization process is complete, the compound may flow down and accumulate in the lower part of the windings.

The first two operations – moisture extraction and impregnation – were performed for the two test samples in the same way. The procedure for the third operation – drying – was different for the first and second samples. The first rotor was installed in the drying chamber with the “heavy place” down, and the second – with the “heavy place” up. Fig. 4 schematically shows the installation position of the first and second rotor samples in the drying oven.

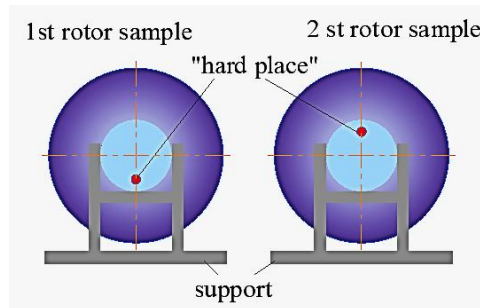

Fig. 4. Installation positions of the 1st and 2nd rotor samples in the drying oven

Thus, different conditions for the influence of uneven compound distribution on unbalance were created. For the first rotor, an increase in unbalance was expected during the drying process due to additional compound accumulation in the “hard place”. For the second rotor, a decrease in unbalance was expected due to the accumulation of compound residues in the part of the rotor opposite the “hard place”.

The used method of controlling the compound distribution over the rotor volume can be considered a unique case of improving the balancing of rotating masses. Of course, this method can be applied exclusively to rotors of electric machines undergoing the winding impregnation operation.

**Obtaining results during the experiments.** The results of measuring vibration parameters (vibration speeds) were obtained from the test protocols of the balancing machine. Digivibe MX M10 software was used to visualize the measurement results. Table 2 presents the results of five steps of balancing one of the rotors before impregnation. The balancing results are given in the form of tables of vibration speeds for plane A and plane B. Planes A and B are balancing planes, that is, planes in which it is structurally possible to install balancing weights.

Table 2. Results of determining vibration speed from rotor imbalance before impregnation

Step	Common, mm/s	Filter, mm/s	Max, mm/s	Phase, degree	Step	Common, mm/s	Filter, mm/s	Max, mm/s	Phase, degree
<b>Balancing plane A</b>					<b>Balancing plane B</b>				
<b>Step 1</b>	14,19	8,50	8,96	210	<b>Step 1</b>	18,38	11,60	12,23	14
<b>Step 2</b>	39,59	25,50	26,35	238	<b>Step 2</b>	28,08	18,18	18,76	40
<b>Step 3</b>	9,78	5,68	5,92	165	<b>Step 3</b>	16,74	10,77	11,15	312
<b>Step 4</b>	6,48	1,71	2,87	144	<b>Step 4</b>	5,58	3,25	3,41	303
<b>Step 5</b>	5,53	0,23	2,48	203	<b>Step 5</b>	2,06	0,62	0,64	203

The designations adopted in Table 2:

- Step 1... Step 5 – steps for determining the imbalance indicators;
- Step 1 – determination of vibration speed for the initial rotor imbalance;

- Step 2 – measurement of vibration speed of the rotor with imbalance from a test load of arbitrary mass placed in the balancing plane A;
- Step 3 – measurement of vibration speed of the rotor with imbalance from a test load of arbitrary mass placed in the balancing plane B;
- Step 4 – determination of rotor imbalance with balancing loads placed in the plane A and plane B;
- Step 5 – control step for correcting the results.
- Common – value of vibration speed of the general vibration background. Due to the high sensitivity of the vibration sensors, they record any vibrations, including those not related to imbalance;
- Filter – value of vibration speed of vibrations filtered from external interference;
- Max – maximum peak value of vibration speed;
- Phase – unbalance phase.

Fig. 5–8 shows hodographs of unbalance phases when performing measurements in steps Step 1... Step 5 for the 1st and 2nd rotor samples before and after impregnation.

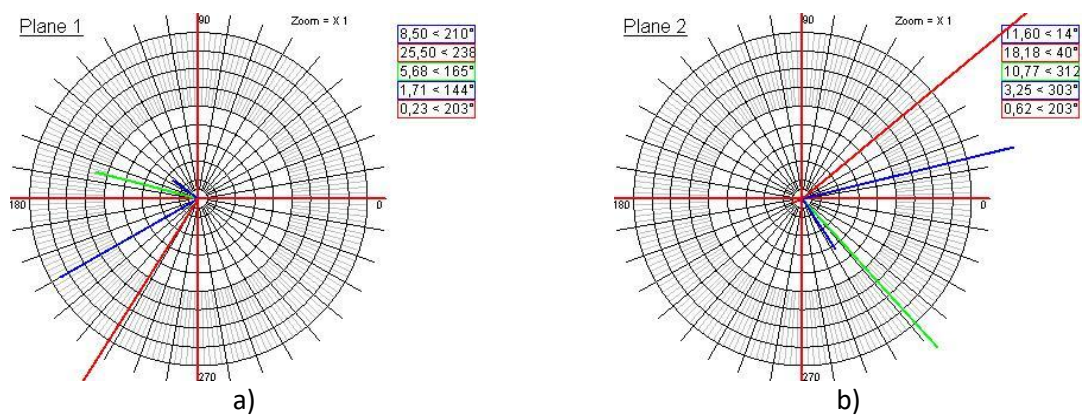

Fig. 5. Hodographs of vibration speed at different steps of balancing the 1st rotor sample (balancing before impregnation m): a – balancing plane A; b – balancing plane B

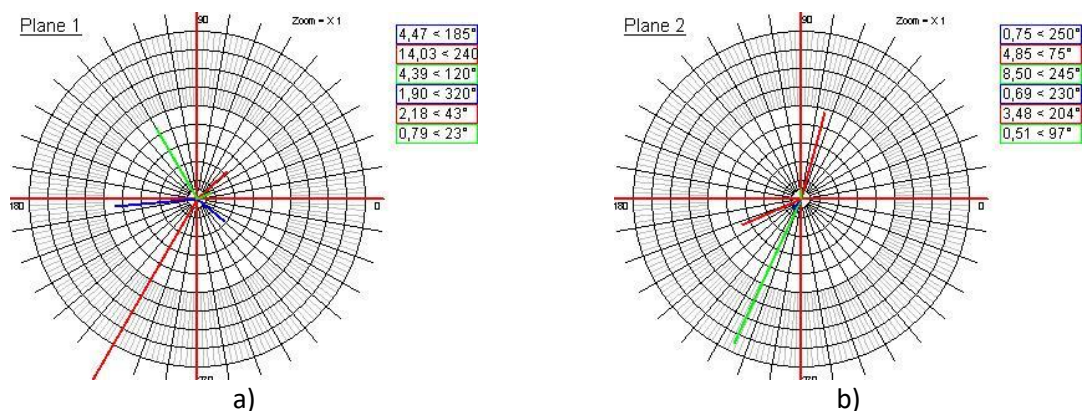

Fig. 6. Hodographs of vibration speed at different steps of balancing the 1st rotor sample (balancing after impregnation): a – balancing plane A; b – balancing plane B

As can be seen from the results presented, the difference in the magnitude of the vibration velocities associated with the rotor imbalance measured before and after impregnation is quite significant. Moreover, as expected, for the 1st sample, the imbalance increased by 86% – for balancing plane A and 52% – for balancing plane B. On the contrary, for the 2nd sample, the imbalance decreased, respectively – by 69% and 83%.

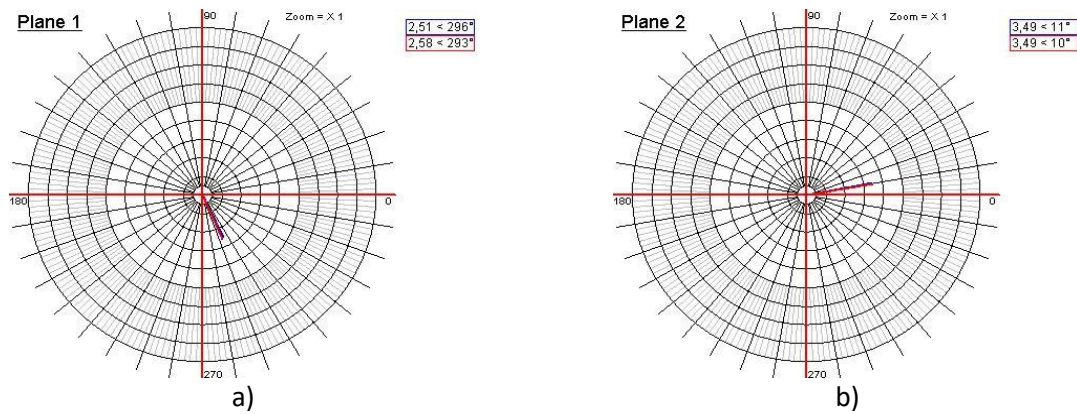

Fig. 7. Hodographs of vibration speed at different steps of balancing the 2nd rotor sample (balancing before impregnation m): a – balancing plane A; b – balancing plane B

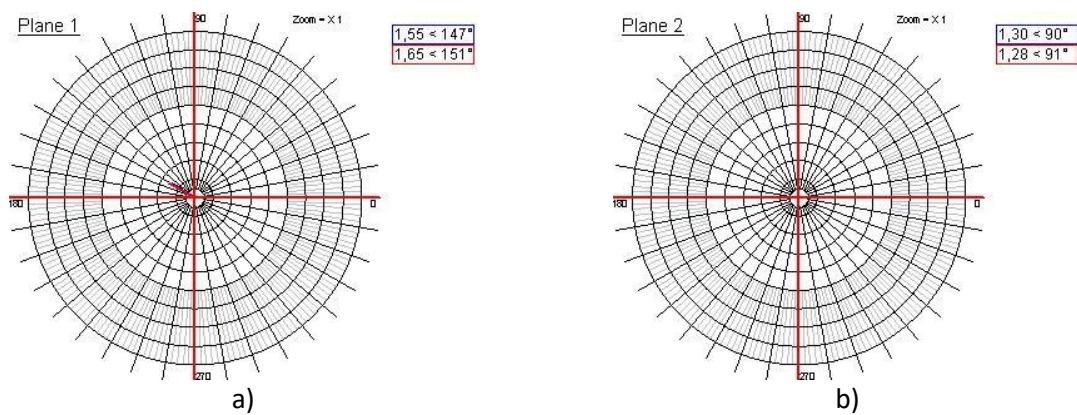

Fig. 8. Hodographs of vibration speed at different steps of balancing the 2nd rotor sample (balancing after impregnation): a – balancing plane A; b – balancing plane B

Table 3. Comparative values of rotor vibration speed and phase imbalance before and after impregnation of windings

Rotor condition	balancing plane A		balancing plane B	
	vibration speed, mm/s	phase imbalance, degree	vibration speed, mm/s	phase imbalance, degree
<b>1st rotor sample</b>				
before impregnation	0,23	203	0,62	203
after impregnation	1,69	151	1,28	91
relative change in unbalance index, %	86%		52%	
<b>2st rotor sample</b>				
before impregnation	2,58	293	3,49	10
after impregnation	0,79	23	0,59	97
relative change in unbalance index, %	-69%		-83%	

It is clear that this does not exclude the need to balance the rotor after the impregnation operation. However, impregnation using the “heavy place up” method reduces the mass of the balancing loads, which improves the balancing parameters. The expected decrease in the mass of the balancing loads is proportional to the decrease in vibration velocities, as an indirect indicator of imbalance.

**Conclusions.** The results of the conducted research confirm the hypothesis that it is possible to partially compensate for the static imbalance of rotors by controlling the distribution of the compound when applying electrical insulation (impregnation) of the windings. Controlling the distribution of the compound consists in fixing the rotor in the drying chamber in a position corresponding to the phase angle of the “heavy spot”, namely by placing it upwards. Controlling the distribution of the compound over the rotor volume can be considered as a method of improving balancing performance by technological means.

## REFERENCES

- Danylevskiy, V. & Zaika, D. (2018). Extension of electric locomotive operation with use of new newest materials in capital repair. *Transport Systems and Technologies*, 1(32), 14–25. <https://doi.org/10.32703/2617-9040-2018-32-1-14-25>.
- Hildinger, T., Weidner, J. (2017). Progress in development of a nanocomposite stator winding insulation system for improved generator performance. *2017 IEEE Electrical Insulation Conference. (EIC)*. 139–142. <https://doi.org/10.1109/EIC.2017.8004655>.
- Wrobel, R., Williamson, S. J., Booker, J. D., & Mellor, P. H. (2016). Characterizing the in situ thermal behavior of selected electrical machine insulation and impregnation materials. *IEEE transactions on industry applications*, 52(6), 4678–4687. <https://doi.org/10.1109/TIA.2016.2589219>.
- Verba, I. & Danilenko, O. (2018). Balancing rotating tool systems: many questions and some answers. *Promising technologies and devices*, (12), 30–38. [http://www.irbis-nbu.gov.ua/cgi-bin/irbis\\_nbu/cgiirbis\\_64.exe?C21COM=2&I21DBN=UJRN&P21DBN=UJRN&IMAGE\\_FILE\\_DOWNLOAD=1&Image\\_file\\_name=PDF/ptp\\_2018\\_12\\_6.pdf](http://www.irbis-nbu.gov.ua/cgi-bin/irbis_nbu/cgiirbis_64.exe?C21COM=2&I21DBN=UJRN&P21DBN=UJRN&IMAGE_FILE_DOWNLOAD=1&Image_file_name=PDF/ptp_2018_12_6.pdf). [in Ukraine].
- Tiwari, R. (2017). Rotor systems: analysis and identification. *CRC press*. 1092. <https://doi.org/10.1201/9781315230962>.
- Ágoston, K. (2015). Fault detection of the electrical motors based on vibration analysis. *Procedia technology*, 19, 547–553. <https://doi.org/10.1016/j.protcy.2015.02.078>.
- Ibraheem, A. A., Ghazaly, N. M., & Abd el-Jaber, G. (2019). Review of rotor balancing techniques. *American Journal of Industrial Engineering*, 6(1), 19–25. <https://doi.org/10.12691/ajie-6-1-3>.
- Khudonogov, A., Dulskiy, E., Ivanov, P. (2018). Basis for Local Methods of Insulation Hardening of Traction Rolling Stock Electrical Machines. *International Scientific Conference Energy Management of Municipal Transportation Facilities and Transport EMMFT 2017. EMMFT 2017*. 692. 109–119. [https://doi.org/10.1007/978-3-319-70987-1\\_12](https://doi.org/10.1007/978-3-319-70987-1_12)
- Liu, M., Li, Y., Ding, H., & Sarlioglu, B. (2017). Thermal management and cooling of windings in electrical machines for electric vehicle and traction application. *2017 IEEE Transportation Electrification Conference and Expo (ITEC)*. 668–673. <https://doi.org/10.1109/ITEC.2017.7993349>.
- Safiyev, E., Rahimli, I., & Mammadov, N. (2024). Method of qualitative impregnation of electric motor windings. *Przegląd Elektrotechniczny*, 8, 238. <https://doi.org/10.15199/48.2024.08.48>.
- Wrobel, R., Williamson, S. J., Booker, J. D., & Mellor, P. H. (2016). Characterizing the in situ thermal behavior of selected electrical machine insulation and impregnation materials. *IEEE Transactions on Industry Applications*, 52(6), 4678–4687. <https://doi.org/10.1109/TIA.2016.2589219>.
- Liu, H., Ayat, S., Wrobel, R., & Zhang, C. (2019). Comparative study of thermal properties of electrical windings impregnated with alternative varnish materials. *The Journal of Engineering*, 2019(17), 3736–3741. <https://doi.org/10.1049/joe.2018.8198>.
- Morais, T. S., Der Hagopian, J., Steffen Jr, V., & Mahfoud, J. (2014). Optimization of unbalance distribution in rotating machinery with localized non linearity. *Mechanism and Machine Theory*, 72, 60–70. <https://doi.org/10.1016/j.mechmachtheory.2013.09.012>.
- Shostak, Y., Holovashchenko, O., Reshetnikov, Y., Tkachenko, V. (2024). Improvement of the technological process balancing electric machine rotors on a balancing machine. *Eastern-European Journal of Enterprise Technologies*, 4(7(130)), 60–69. <https://journals.uran.ua/eejet/article/view/309867>.
- Jiang, L., Shi, C., Li, X., Ma, H., & Cao, Y. (2025). Dynamic balance optimization method for aero-engine rotor without trial weight. *Advances in Mechanical Engineering*, 17(6). <https://doi.org/10.1177/16878132251343928>.
- Mamontov, O. (2025). Vibration method for measuring static unbalance of rigid rotors. *Ukrainian Metrological Journal*, (1), 34–40. <http://umj.metrology.kharkov.ua/article/view/325890>. [in Ukraine].

17. Babenko, O., Lavrenko, Ya., & Kurenkov, M. (2014). The influence of static and dynamic imbalance on the oscillations of the centrifuge shaft, taking into account gyroscopic effects. *Journal of Mechanical Engineering NTUU" Kyiv Polytechnic Institute"*, (70), 36–42. <https://doi.org/10.20535/2305-9001.2014.70.35249>. [in Ukraine].

**Ярослав Шостак<sup>1</sup>, Юрій Решетніков<sup>2</sup>**

<sup>1</sup>Аспірант кафедри електромеханіки та рухомого складу залізниць, Національний транспортний університет, вул. Михайла Омеляновича-Павленка, 2, 01010, м. Київ, Україна. ORCID: <https://orcid.org/0009-0006-2886-3264>.

<sup>2</sup>Асистент кафедри електромеханіки та рухомого складу залізниць, Національний транспортний університет, вул. Михайла Омеляновича-Павленка, 2, 01010, м. Київ, Україна. ORCID: <https://orcid.org/0009-0009-3893-1736>.

### **Удосконалення технології просочення обмоток тягових двигунів з метою поліпшення параметрів розбалансу ротора**

**Анотація.** Робота присвячена поліпшенню якісних показників балансування роторів електричних машин технологічними методами на прикладі капітального ремонту тягових електродвигунів електропоїздів серій EP2, EP9, ЕПЛ2, ЕПЛ9, ЕД9 на ПрАТ «Київський електровагоноремонтний завод». Проаналізовано особливості технологічного процесу усунення механічного дисбалансу роторів при виготовленні і ремонті електричних двигунів. З'ясовано причини механічного дисбалансу роторів. Експериментально досліджено ступінь впливу на дисбаланс роторів нерівномірності розподілу компаунду просочення по об'єму електричних обмоток. Підтверджено висунуту гіпотезу про можливість часткової компенсації статичного дисбалансу роторів шляхом управління розподілом компаунда при нанесенні електричної ізоляції (просочуванні) обмоток. Запропоновано метод управління розподілом компаунда при просочуванні. Сутність методу полягає у фіксації ротора у сушильній камері у положенні, що відповідає фазовому куту «важкого місця», а саме – шляхом його розташування «важким місцем» вгору. Управління розподілом компаунда по об'єму ротора може розглядатися, як технологічний метод поліпшення показників балансування. Метод дає можливість поліпити якісні показники балансування за рахунок зменшення маси балансувальних вантажів при остаточному балансуванні роторів на величину до 70%.

**Ключові слова:** залізничний транспорт, вагони, електропоїзд, балансування роторів, тягові електродвигуни, електрична ізоляція обмоток, просочення обмоток.

Дата першого надходження статті до видання 02.10.2025

Дата прийняття до друку статті 25.11.2025

DOI:10.32703/2617-9040-2025-46-14

UDC:321.01-14

**Vitalii Samoilyk<sup>1</sup>, Valerii Samsonkin<sup>2</sup>, Oleksii Vynohradov<sup>3</sup>, Oleksandra Soloviova<sup>4</sup>, Iryna Biziuk<sup>5</sup>**

<sup>1</sup>Master of Transport Technologies, train driver at Municipal enterprise “Kyiv Metro”, 35, Beresteyskyi Avenue, Kyiv, 03056. ORCID: <http://orcid.org/0009-0005-6626-1275>.

<sup>2</sup>Doctor of science, professor at the Department of Transport Technologies and Transportation Process Management, 1 Mykhailo Omelianovych-Pavlenko Str., Kyiv, 01010, Ukraine. ORCID: <http://orcid.org/0000-0002-1521-2263>.

<sup>3</sup>Postgraduate student at the Department of Transport Technologies and Transportation Process Management, 1 Mykhailo Omelianovych-Pavlenko Str., Kyiv, 01010, Ukraine. ORCID: <https://orcid.org/0009-0001-9096-9020>.

<sup>4</sup>PhD, senior lecturer at the Department of Transport Technologies and Transportation Process Management, 1 Mykhailo Omelianovych-Pavlenko Str., Kyiv, 01010, Ukraine. ORCID: <http://orcid.org/0000-0002-7933-3929>.

<sup>5</sup>Senior Lecturer at computer and control systems department, Ukrainian State University of Railway Transport, 7 Feuerbach Square, Kharkiv, 61050, Ukraine, ORCID: <http://orcid.org/0000-0002-6458-5701>.

\*Corresponding author: [legals44@yahoo.com](mailto:legals44@yahoo.com).

## **The Human Factor in Metro Operations: Determining the Driver's Condition During Pre-Departure Procedures**

*The article analyzes the influence of the human factor on the reliability and safety of metro operations, focusing on the methods for assessing the psychophysiological state of train drivers before the start of a work shift. The study examines the current system of human factor monitoring implemented in the Kyiv Metro and emphasizes the need for objective diagnostic tools in daily safety control. Experimental research based on Schulte-Gorbov tables was conducted to evaluate attention stability, perception speed, and cognitive response of metro drivers. A month-long self-testing experiment performed before and after shifts revealed statistically significant differences depending on the driver's condition - normal, drowsy, or fatigued. The analysis demonstrated that fatigue and reduced alertness lead to slower reaction time and lower concentration, negatively affecting driving safety. The results confirm the effectiveness of the Schulte test as a practical tool for monitoring the psychophysiological readiness of metro drivers and for preventing human-factor-related errors during transport operations.*

**Keywords:** rail transport, human operator, automated control, ergatic system, psychophysiological state of the driver, testing.

The automation of metro operations under global digitalization is one of the key directions in the development of passenger transportation systems in urban rail transit. Metro trains with automated train operation (ATO) are classified by levels of automation, ranging from fully manual control to complete autonomy governed by an onboard computer. Currently, four levels of automation are defined (commonly referred to as Grades of Automation or GoA):

1. GoA 1 (Grade of Automation 1): trains require continuous presence of a driver who is responsible for acceleration, braking, and door operations.
2. GoA 2: partially automated trains, where acceleration and braking are performed automatically, but the driver remains responsible for stopping at stations and door control.

3. GoA 3: there is no driver in the cab, but a staff member is onboard to monitor door operations and respond to emergencies, while all other functions are automated.

4. GoA 4 (Unattended Train Operation – UTO): fully autonomous trains operated entirely by the onboard computer system without any human presence, including door operations.

Experts in the field of ATO design and implementation emphasize that major technological disasters typically result not from a single cause, but from a chain of multiple contributing factors forming a fatal sequence. While the causes of such incidents may vary, they are almost always united by a common element: the human factor.

From a technological standpoint, full automation of metro train operations is simpler than developing self-driving cars. However, the potential consequences of safety violations in rail transport are significantly more severe. This may explain why the global transition to driverless metro systems is occurring more slowly than expected.

Nevertheless, the number of metro lines operating under automated control continues to grow. Some systems have already eliminated human drivers entirely or are gradually reducing their number. The primary reason why the Kyiv Metro is not yet prepared for driverless trains is the intensity of train traffic. For safe operation without drivers, the headway between trains must be at least 2.5 minutes, while in Kyiv it is often significantly shorter. Additional challenges include the inability to remotely resolve technical malfunctions. Another obstacle is the high financial cost of implementing ATO, which may not be offset by simply replacing the driver with automation, as this requires extensive upgrades to trains, stations, track infrastructure, and signalling systems. Therefore, ensuring the reliability of the human driver will remain a relevant and critical issue for the foreseeable future. The article explores the issue of diagnosing the driver's condition at various stages of the work shift.

**Analysis of recent research and problem statements.** Research on the human factor in railway transport is a cornerstone of traffic safety. Contemporary approaches are shifting from reactive analysis of consequences to proactive risk management, which implies the identification of latent failures, psychophysiological limitations of operators, and organizational shortcomings.

Study [1] presents the REVIEW methodology for proactive assessment of organizational safety, which enables the identification of hidden risk factors at the managerial level. It distinguishes three groups of determinants: policy and management decisions, workplace culture, and operational conditions. The method has proven effective in detecting systemic causes of accidents and engaging personnel in safety management. However, this approach focuses on organizational aspects and does not account for the individual psychophysiological characteristics of the driver prior to departure.

In [2], it is emphasized that the human factor remains central at all stages of the system life cycle. The authors criticize the excessive reliance on standards EN 50126–EN 50129, proposing to integrate ergonomic and cognitive analysis into system design to reduce the likelihood of human error. Nevertheless, their focus lies on standardized procedures and quantitative risk assessment without real-time diagnostics of the driver's condition, which prevents capturing short-term fluctuations in attention and performance.

Article [3] justifies the application of the Model-Based Systems Engineering (MBSE) methodology for integrating safety requirements into the design process, ensuring traceability of risks and consistency between technical and “human” aspects. Yet, this model-oriented approach does not encompass individual psychophysiological factors of personnel during actual operation; there remains a need for real-time assessment tools for drivers' states to complement engineering methods.

Study [4] investigates the relationship between neuroticism, occupational stress, and psychological symptoms in metro drivers: high neuroticism amplifies stress and fatigue, impairing work quality. Work demonstrates the role of safety culture (employee participation,

communication, training) in reducing accident rates and enhancing collective psychological resilience. However, these studies rely mainly on subjective questionnaires without objective, real-time measurements of operator state.

Paper [5] classifies types of fatigue (physical, mental, central) and distractions (visual, auditory, cognitive, biomechanical); major risk factors include monotony, circadian rhythm disruption, and sleep deprivation. Research [6] develops the concept of objective monitoring, proposing an algorithmic model for detecting cognitive distractions using ECG and HRV data, achieving high classification accuracy - confirming the potential of automated real-time driver monitoring. Nevertheless, these works emphasize signal processing without demonstrating implementation in actual metro conditions (short runs, high traffic frequency, compact cabins) or integration into pre-departure procedures.

Study [7] analyzes SIL allocation practices in EU countries and proposes unifying risk acceptance approaches for interoperability. Article [8] stresses the integration of functional safety and cybersecurity into a single risk management framework, as cyber threats can compromise safety. However, these works maintain a regulatory–technical focus, neglecting the human factor as a source of hazard and lacking mechanisms for operational monitoring of operators’ psychophysiological states.

Article [9] proposes an integrated methodology for assessing metro drivers’ fatigue risk based on the AHP–FCE model, which covers physiological, psychological, managerial, and environmental factors, confirming the effectiveness of quantitative fatigue assessment (case study result - “medium” risk). However, it still depends on expert judgments and lacks continuous, objective real-time monitoring before and during operation.

Study [10] surveyed 1,194 Tehran Metro drivers using Samn–Perelli, FAS, and NASA-TLX scales: fatigue significantly increased by the end of the shift, and cognitive workload positively correlated with exhaustion (greatest contributors — time pressure and cognitive demands). The limitation lies in the exclusive use of self-assessment tools without biometric data, making it impossible to detect the exact onset of dangerous fatigue.

Work [11] compares automation levels GoA1–GoA4: at lower automation levels (GoA1–GoA2), cognitive workload and fatigue are higher; at higher levels (GoA4), workload decreases, but the risk of losing situational awareness grows. The driver remains a critical control and response element. However, this study provides only comparative analysis without instruments for objective real-time assessment of individual driver states.

Article [12] analyzes behavioural risk models in the railway sector, considering individual psychophysiological characteristics, safety culture, and technical aspects of interaction with automated systems. It recommends continuous personnel monitoring and the use of biometric sensors. Yet, the study remains largely conceptual, lacking validated measurement protocols and practical implementation tools.

Organizational and regulatory tools (REVIEW, SIL, MBSE) are necessary but insufficient without considering the individual operator’s condition. Safety culture and psychological factors (stress, neuroticism) substantially affect reliability but are still assessed mostly through subjective measures. Biometric and machine-learning approaches demonstrate potential for objective monitoring; however, they require adaptation to metro-specific constraints and integration into pre-operation procedures.

Despite the increasing levels of automation (GoA2–GoA4), the driver remains the critical link in the human-machine (ergatic) system: vigilance, reaction speed, fatigue, and concentration directly determine traffic safety. Existing methods - from organizational frameworks (REVIEW, SIL, MBSE) to safety-culture programs - do not provide fast, objective

evaluation of a specific driver's functional readiness immediately before a trip. Medical-psychological examinations are largely formal and fail to reflect the driver's current psychophysiological state at the moment of duty clearance. Subjective questionnaires cannot capture short-term critical changes, while biometric monitoring technologies have not yet been fully integrated into real metro operations.

Therefore, it is essential to ensure the reliability of the human factor in metro driver activity by developing an objective, rapid, and operationally applicable system for assessing their psychophysiological condition prior to a trip. Such a system should combine validated biometric indicators (e.g., HRV, attention and reaction tests), algorithms for detecting risk states, and clear threshold criteria for work clearance; it must be compatible with cabin and schedule constraints and seamlessly embedded into safety processes - complementing existing regulatory and organizational mechanisms.

**The purpose and tasks of the study.** The purpose of the study is to analyze the use of Schulte tables for diagnosing the functional state of a metro train driver.

The task of the study:

1. To identify the existing system for ensuring human reliability in the Kyiv Metro.
2. To conduct an experiment aimed at assessing the functional state of a train driver using the Schulte table test.
3. To process the experimental results and determine relevant patterns and regularities.

**Materials and methods of research.**

### 1. Identification of the Existing Human Reliability Assurance System in the Kyiv Metro

The impact of human factors on violations of traffic safety in transportation systems is highly significant. Therefore, there is a pressing need to develop a comprehensive set of tools for monitoring the human condition, designing safety systems in vehicles involved in passenger and freight transportation, implementing hygienic measures, reducing working hours, and more [13, 14]. The "human factor" in this context is considered from two perspectives: (1) the objective determination of the degree of human involvement in safety violations; and (2) the creation of systems and technical means for monitoring, training, and duplicating human activities.

Additionally, attention should be paid to the three-level manifestation of the human factor's influence:

1. Individual human factor – actions of train drivers, dispatchers, and other personnel whose direct behaviour led to safety violations;
2. Work organization – incorrect decisions made by supervisors, maintenance crews, outdated operational instructions, which indirectly contributed to violations;
3. Design and engineering level - errors or shortcomings made by developers of technical equipment, documentation, and technological solutions, including manufacturers, research institutions, design, and engineering organizations.

Human activity within the railway transport system can be characterized by its final result RR, which is determined by the following function:

$$KP = f(C \cdot H \cdot 3), \quad (1)$$

where  $CC$  – predisposition to perform a specific type of work;

$LL$  – level of training;

$HH$  – current health condition.

Thus, the final result represents an integrated expression of these three components. However, a tangible outcome can only be achieved when each component has a non-zero value. If any of the components equals zero, the overall effectiveness of a person's activity within the railway transportation system will also equal zero.

Let us consider the implementation of the three components from equation (1) [15] within transport systems.

(1) *Predisposition.*

An individual's predisposition to perform a specific job is assessed through a professional selection system. The main objective of professional selection is to identify and recruit individuals who are most capable of efficiently performing the required tasks. Depending on the level of responsibility and the impact of a given profession, various types of professional selection are applied in the transportation sector, including:

1. Socio-educational selection, which determines the level of education, living conditions, age, professional skills, and a range of social and psychological characteristics (e.g., predisposition to disciplinary violations, personality traits, etc.);
2. Medical selection, which aims to assess an individual's state of health and its suitability for the chosen profession;
3. Psychophysiological selection, aimed at identifying professionally important qualities necessary for acquiring knowledge, skills, and abilities, and which influence the success of training and effectiveness in professional activity;
4. Psychological selection, which focuses on identifying psychological traits that are critical for successfully performing the given job.

(2) *Level of Training*

This component reflects the amount of knowledge and expertise possessed by a given specialist. It includes:

1. Basic education received in accredited institutions of levels II–IV;
2. Secondary education or retraining obtained at institutions of levels III–IV;
3. Advanced professional training;
4. Experience exchange through participation in seminars, conferences, workshops, and other scientific or technical forums as an attendee or speaker;
5. Self-education, including engagement with professional literature and relevant media (libraries, mass media, internet) to enhance subject knowledge or broaden professional outlook.

(3) *Health Status or Functional Psychophysiological State*

This component is maintained in four key areas, as regulated by the company or employer:

- a) periodic medical and psychological examinations;
- b) pre-shift health screening to assess the worker's fitness to perform duties;
- c) intra-shift monitoring of the current condition to evaluate ability to continue working;
- d) post-shift evaluation aimed at determining the need for recovery measures after duty completion.

Additionally, individual responsibility for maintaining one's own health plays a role, which depends on both the personal cultural level and the corporate culture of the organization.

A study was conducted under the conditions of the Kyiv Metro to evaluate the real-time condition of train operators. It is well known that the train operator plays a key role in ensuring the safety of passenger train movement.

To assess the functional state of the train driver, a psychophysiological method — the Schulte Tables Test - was proposed [16].

The essence of working with Schulte tables lies in the rapid and sequential identification of all numbers or other objects arranged within the grid. The table size may vary, but most commonly it is 5×5 or 7×7. The tables can be either colored (most often red and black) or non-colored. During testing, the primary emphasis is placed on the speed of number recognition. Typically, Schulte tables are used to develop the pace of information perception, as well as to assess the current state of this cognitive function. Continuous practice with Schulte tables enhances peripheral vision. A wide visual field reduces the time required to locate relevant information segments. Furthermore, the use of such tables improves the speed of visual scanning movements.

Additionally, Schulte tables are frequently employed in neuro-linguistic programming (NLP) training to achieve a so-called "high-performance state." This state is characterized by a shift in

consciousness from critical perception to a certain level of detachment, allowing individuals to perform logical and sequential tasks more efficiently. In essence, this effect is also important for speed reading.

Schulte tables are well-known among psychologists, psychophysicists, educators, and human factors specialists under alternative names such as Schulte–Gorbov Tables or Schulte–Platonov Tables.

In the current experiment, red-and-black Schulte–Gorbov Tables [17] were used, as illustrated in Figure 1.

12	21	23	21	15	19	9
2	11	12	14	5	10	19
3	25	6	8	13	17	16
10	3	9	17	1	18	18
6	8	22	7	4	24	14
20	4	23	24	20	2	22
1	7	15	16	13	5	11

*Fig. 1. Appearance of red-and-black Schulte–Gorbov tables*

The tasks assigned to the subject primarily involve: (a) the sequential search for numbers of a single color in ascending or descending order, and (b) a mixed search pattern: black numbers in ascending order and red numbers in descending order, i.e., 1 black, 25 red, 2 black, 24 red, ... 24 black, 1 red. The test completion time is recorded for each session. The researcher conducting the experiment in 2023 was V. O. Samoylyk, then a graduating student and now a co-author of this article, who at the time worked as a train operator for the Kyiv Metro.

#### Experimental Design

The researcher was instructed to perform self-testing using the Schulte–Gorbov tables before and after each work shift. The duration of the study was one month.

Each self-test session included the following steps:

1. Accessing the red-and-black Schulte–Gorbov table online via the website: <https://cepia.ru/speedreading/schulte/gorbov>
2. Completing a single test using the mixed number search method (variant (b) described under Figure 2), with precise measurement of test completion time;
3. Recording the completion time in the experiment log.

#### Research Hypothesis

The hypothesis of the experiment was to confirm the statistical significance of the difference in test results before and after the work shift.

#### Results of the Research

Identification of the Human Reliability Assurance System in the Kyiv Metro.

A study was conducted within the operational environment of the Kyiv Metro to examine the key aspects of human factor integration. Based on this research, a structured model for ensuring human reliability was developed, as illustrated in Figure 2.

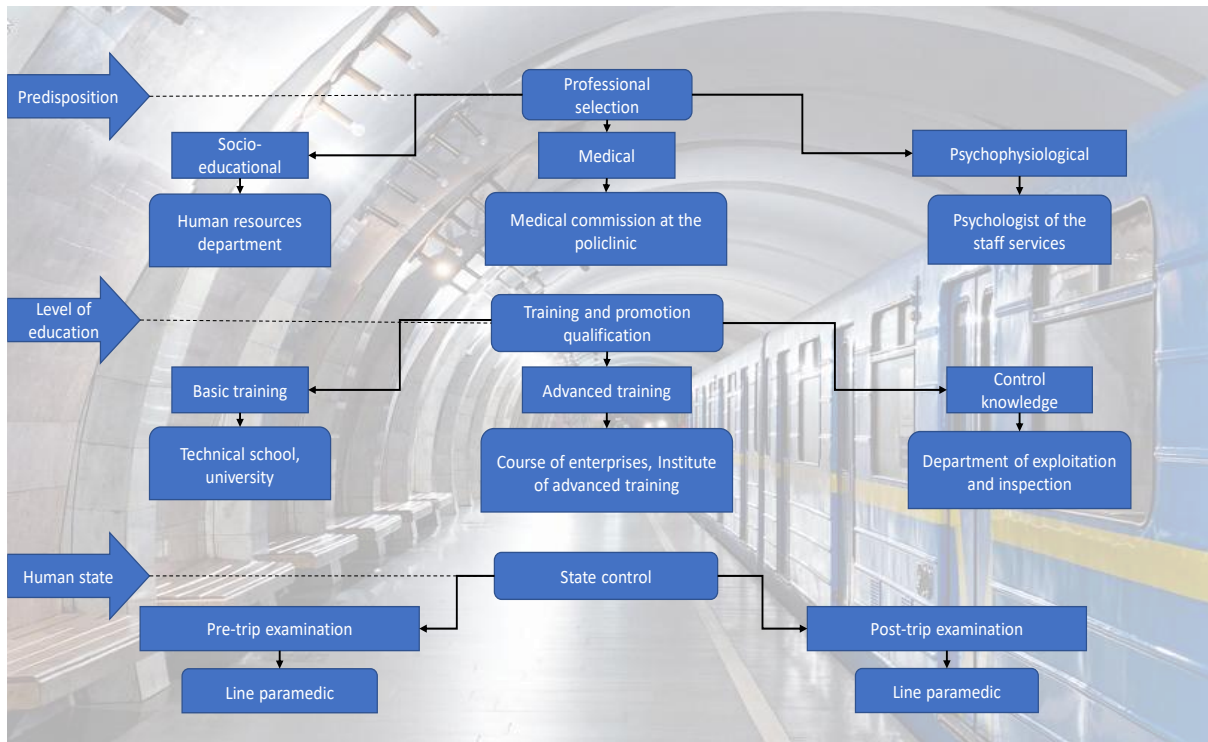

Fig. 2. Human Reliability Assurance System in the Kyiv Metro

2. Conducting an Experiment to Determine the Condition of a Metro Train Operator Using the Schulte Method

The results of the experiment are presented in Table 1.

Table 1. Experimental Results for Determining the Functional State of the Train Operator

№	Date	Day of the week	Before the shift		After the shift	
			Test time/Well-being	Result	Test time / Well-being	Result
1	2	3	4	5	6	7
1	29.09	Fri	14:02/N	1:44	21:32/N	2:31
2	30.09	Sat	07:09/D	1:50	14:39/N	2:32
3	01.10	Sun	16:45/N	1:29	-	-
4	02.10	Mon	-	-	09:05/F	2:42
5	03.10	Tue	10:00	1:18	16:00	1:33
6	04.10	Wed	07:04/D	1:34	14:31/N	1:23
7	05.10	Thu	12:35/N	1:26	16:35/N	1:52
8	06.10	Fri	07:25/N	1:55	15:11/N	2:40
9	07.10	Sat	09:00/N	1:33	15:39/N	1:59

Continuation of Table 1

1	2	3	4	5	6	7
10	08.10	Sun	07:20/N	2:00	13:31/N	2:21
11	09.10	Mon	07:01/D	2:05	13:16/N	2:26
12	10.10	Tue	13:39/N	1:45	20:31/N	2:01
13	11.10	Wed	17:26/N	1:49	-	-
14	12.10	Thu	-	-	09:01/F	3:01
15	13.10	Fri	06:30/D	2:01	13:31/N	1:41
16	14.10	Sat	09:03/N	1:18	16:51/N	3:15
17	15.10	Sun	10:00/N	1:19	16:00/N	1:01
18	16.10	Mon	10:00/N	1:23	16:00/N	1:17
19	17.10	Tue	10:00/N	1:21	16:00/N	1:20
20	18.10	Wed	16:41/N	1:33	-	-
21	19.10	Thu	-	-	09:01/F	4:00
22	20.10	Fri	06:30/F	1:59	13:30/N	1:25
23	21.10	Sat	16:41/N	1:40	-	-
24	22.10	Sun	-	-	09:01/F	4:05
25	23.10	Mon	06:35/D	2:30	13:30/N	1:30
26	24.10	Tue	10:00/N	1:00	16:00/N	1:22
27	25.10	Wed	17:00/N	1:42	-	-
28	26.10	Thu	-	-	09:06/F	4:55
29	27.10	Fri	06:30/D	2:00	13:30/N	1:49
30	28.10	Sat	13:02/N	0:59	19:57/N	1:31
31	29.10	Sun	10:23/N	1:17	17:00/N	1:39
32	30.10	Mon	13:34/N	1:15	19:34/N	1:52

Days off are highlighted with a yellow background. The letter *N* indicates a normal state of well-being, *D* (Drowsy) indicates a drowsy condition, and *F* (Fatigued) indicates fatigue.

### 3. Processing of Experimental Results and Identification of Patterns

The processing of the experimental results was carried out under the assumption that the statistics of the outcomes follow a normal probability density distribution of test completion time ( $x$ ), described by formula (2)

$$f(x) = \frac{1}{\sqrt{2 \cdot \pi} \cdot \sigma} \cdot e^{-\frac{(x-m)^2}{2\sigma^2}}, \quad (1)$$

where  $m$  is the mathematical expectation (mean) of the continuous random variable  $x$ , representing the time to complete the Schulte-Gorbov test;

$\sigma$  is the standard deviation, or the root mean square deviation of the random variable  $x$  from its mean value  $m$ , which serves as an analogue of variance - that is, the dispersion of  $x$  around the distribution center  $m$ .

The relation (2) is well known. However, the inclusion of this formula in the article is explained by the need for a clear understanding of the parameters given below.

In a normal distribution (2) about 70% (68.27%) of all possible values of  $x$  lie within the interval  $m \pm \sigma$  [18].

Interval:

$$[m - \sigma, m + \sigma] = \text{norm}. \quad (3)$$

We will refer to this as the **norm** of a random process described by the random variable  $x$ . Thus, in order to determine the norm for V. Samoilyk's condition, two parameters must be known:  $m$ ,  $\sigma$ .

It is well known that determining these parameters requires an infinite number of experiments, which is unrealistic. Therefore, in practical mathematical statistics, analogues of these values are used the arithmetic mean

$$\bar{x} \sim m = \frac{\sum_{i=1}^n x_i}{n}, \quad (4)$$

and the standard deviation

$$s \sim \sigma = \sqrt{\frac{\sum_{i=1}^n (x_i - \bar{x})^2}{n-1}}. \quad (5)$$

Now, let us determine the values of  $m$  and  $\sigma$  according to formulas (4) and (5) for the various states of well-being of the test subject.

a) *First, for general information* (Table 1)

We calculate the arithmetic mean using the formula for the overall result of the experiment:

$$\bar{x} \sim m = \frac{\sum_{i=1}^n x_i}{n} = 1,9 \text{ min.} = 1 \text{ min.} 54 \text{ sec.} (114 \text{ sec.}).$$

We calculate the standard deviation using the formula for the overall result of the experiment:

$$s \sim \sigma = \sqrt{\frac{\sum_{i=1}^n (x_i - \bar{x})^2}{n-1}} = 0.8 \text{ min.} (48 \text{ sec.}).$$

Then, according to equation (3), we determine the overall norm:

$$Norm1 (gen) = [66, 162].$$

b) For the normal functional state (Table 2 derived from Table 1)

**Table 2. Experimental Results for Determining Functional State During Morning Shifts (State N Highlighted with Yellow Background)**

№	Date	Day of the week	Before the shift		After the shift	
			Test time/ Well-being	Result	Test time / Well-being	Result
1	2	3	4	5	6	7
1	30.09	Sat	07:09/D	1:50	14:39/N	2:32
2	03.10	Tue	10:00/N	1:18	16:00	1:33
3	04.10	Mon	07:04/D	1:34	14:31/N	1:23
4	06.10	Fri	07:25/N	1:55	15:11/N	2:40
5	07.10	Sat	09:00/N	1:33	15:39/N	1:59
6	08.10	Sun	07:20/N	2:00	13:31/N	2:21
7	09.10	Mon	07:01/D	2:05	13:16/N	2:26
8	12.10	Thu	-	-	09:01/F	3:01
9	13.10	Fri	06:30/D	2:01	13:31/N	1:41
10	14.10	Sat	09:03/N	1:18	16:51/N	3:15
11	15.10	Sun	10:00/N	1:19	16:00/N	1:01
12	16.10	Mon	10:00/N	1:23	16:00/N	1:17
13	17.10	Tue	10:00/N	1:21	16:00/N	1:20
14	19.10	Thu	-	-	09:01/F	4:00
15	20.10	Fri	06:30/D	1:59	13:30/N	1:25
16	22.10	Sun	-	-	09:01/F	4:05
17	23.10	Mon	06:35/D	2:30	13:30/N	1:30
18	24.10	Tue	10:00/N	1:00	16:00/N	1:22
19	26.10	Thu	-	-	09:06/F	4:55
20	27.10	Fri	06:30/D	2:00	13:30/N	1:49
21	29.10	Sun	10:23/N	1:17	17:00/N	1:39

Using formulas (4) and (5), the following results were obtained:

$$m=2.03 \text{ min.}=2 \text{ min. } 1 \text{ sec. (121 sec.);}$$

$$\sigma=0.93 \text{ min. (56 sec).}$$

**Table 3. Experimental Results for Determining Functional State During Evening Shifts (State N)**

№	Date	Day of the week	Before the shift		After the shift	
			Test time/ Well-being	Result	Test time / Well-being	Result
1	29.09	Fri	14:02/N	1:44	21:32/N	2:31
2	01.10	Sun	16:45/N	1:29	-	-
3	05.10	Thu	12:35/N	1:26	16:35/N	1:52
4	10.10	Tue	13:39/N	1:45	20:31/N	2:01
5	11.10	Wed	17:26/N	1:49	-	-
6	18.10	Wed	16:41/N	1:33	-	-
7	21.10	Sat	16:41/N	1:40	-	-
8	25.10	Wed	17:00/N	1:42	-	-
9	26.10	Thu	-	-	09:06/F	4:55
10	28.10	Sat	13:02/N	0:59	19:57/N	1:31

Using formulas (4) and (5), the following results were obtained:

$$m=1.92 \text{ min.}=1 \text{ min. } 55 \text{ sec. (115 sec.);}$$

$$\sigma=0.94 \text{ min. (56 sec).}$$

**Table 4. Experimental Results for Determining Functional State Under Normal (N) Condition**

№	Date	Day of the week	Before the shift		After the shift	
			Test time/ Well-being	Result	Test time / Well-being	Result
1	2	3	4	5	6	7
1	29.09	Fri	14:02/N	1:44	21:32/N	2:31
2	30.09	Sat	-	-	14:39/N	2:32
3	01.10	Sun	16:45/N	1:29	-	-
4	03.10	Tue	10:00/N	1:18	16:00/N	1:33
5	04.10	Wed	-	-	14:31/N	1:23
6	05.10	Thu	12:35/N	1:26	16:35/N	1:52

Continuation of Table 4

1	2	3	4	5	6	7
7	06.10	Fri	07:25/N	1:55	15:11/N	2:40
8	07.10	Sat	09:00/N	1:33	15:39/N	1:59
9	08.10	Sun	07:20/N	2:00	13:31/N	2:21
10	09.10	Mon	-	-	13:16/N	2:26
11	10.10	Tue	13:39/N	1:45	20:31/N	2:01
12	11.10	Wed	17:26/N	1:49	-	-
13	12.10	Thu	-	-		3:01
14	13.10	Fri	-	-	13:31/N	1:41
15	14.10	Sat	09:03/N	1:18	16:51/N	3:15
16	15.10	Sun	10:00/N	1:19	16:00/N	1:01
17	16.10	Пн	10:00/N	1:23	16:00/N	1:17
18	17.10	Tue	10:00/N	1:21	16:00/N	1:20
19	18.10	Wed	16:41/N	1:33	-	-
20	20.10	Fri	-	1:59	13:30/N	1:25
21	21.10	Sat	16:41/N	1:40	-	-
22	23.10	Mon	-	-	13:30/N	1:30
23	24.10	Tue	10:00/N	1:00	16:00/N	1:22
24	25.10	Wed	17:00/N	1:42	-	-
25	27.10	Fri	-	-	13:30/N	1:49
26	28.10	Sat	13:02/N	0:59	19:57/N	1:31

Overall, for the normal condition, the following results were obtained:

$$m=1.7 \text{ min.}=1 \text{ min. } 42 \text{ sec. (102 sec.);}$$

$$\sigma=0.29 \text{ min. (32 sec).}$$

The norm in the normal state is:

$$Norm_2(H) = [70, 134]. \quad (6)$$

c) For the fatigued functional state (Table 5 derived from Table 1)

**Table 5. Experimental Results for Determining Functional State Under Fatigued (FG) Condition**

№	Date	Day of the week	Before the shift		After the shift	
			Test time/ Well-being	Result	Test time/Well-being	Result
1	02.10	Mon	-	-	09:05/F	2:42
2	12.10	Thu	-	-	09:01/F	3:01
3	19.10	Thu	-	-	09:01/F	4:00
4	22.10	Sun	-	-	09:01/F	4:05
5	26.10	Thu	-	-	09:06/F	4:55

Using formulas (4) and (5), the following results were obtained:

$$m=3.74 \text{ min.}=3 \text{ min. } 44 \text{ sec. (244 sec.);}$$

$$\sigma=0.88 \text{ min. (53 sec).}$$

In the fatigued state, the calculated norm is:

$$Norm3(F) = [171, 277]. \quad (7)$$

For the drowsy functional state (Table 6 derived from Table 1).

**Table 6. Experimental Results for Determining Functional State Under Drowsy (DR) Condition**

№	Date	Day of the week	Before the shift		After the shift	
			Test time/ Well-being	Result	Test time / Well-being	Result
1	30.09	Sat	07:09/D	1:50	-	-
2	04.10	Wed	07.04/D	1:34	-	-
3	09.10	Mon	07.01/D	2:05		
4	13.10	Fri	06:30/D	2:01	-	-
5	23.10	Mon	06:35/D	2:30	-	-
6	27.10	Fri	06:30/D	2:00	-	-

Using formulas (4) and (5), the following results were obtained:

$$m=1.99 \text{ min.}=1 \text{ min. } 59 \text{ sec. (119 sec.);}$$

$$\sigma=0.2 \text{ min. (12 sec).}$$

In the drowsy state, the norm is:

$$Norm(D) = [107, 131]. \quad (8)$$

Now, the calculated data are summarized in the consolidated Table 7.

*Table 7. Operator's Norm in Three Functional States*

State	Value, sec		
	<i>m</i>	$\sigma$	<i>norm</i>
Normal (N)	102	32	[70, 134]
Fatigued (F)	224	53	[171, 277]
Drowsy (D)	119	12	[107, 131]

The norm reflects the quality of test performance, i.e., the readiness for work. For clarity, the results of the norm presented in Table 7 are visualized graphically (see Figure 3).

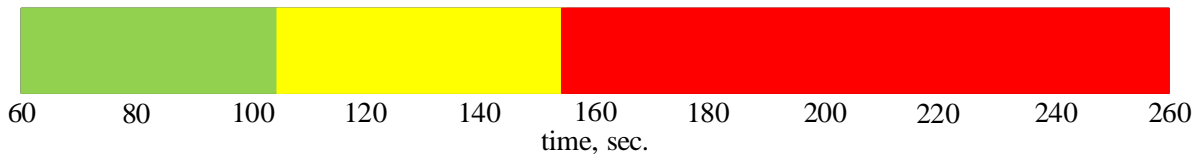

*Figure 3. Norm Positions for Performing the Schulte Psychophysiological Test for Three Operator States: Normal (green), Drowsy (yellow), and Fatigued (red)*

**Conclusions.** Based on the analysis of Table 7 and Figure 3, the following conclusions can be drawn:

1. The normative performance on the Schulte test varies across different functional states;
2. It has been demonstrated that as the operator's condition deteriorates, the normative value shifts to the right, indicating an increase in test completion time, which in turn reflects a decline in attention-switching readiness and driver reaction speed;
3. The hypothesis regarding differences in driver behaviour norms under various conditions, as measured by the Schulte test, has been confirmed;
4. The Schulte psychophysiological test can be effectively used to assess a driver's readiness for duty.

## REFERENCES

1. Edkins, G. D., & Pollock, C. M. (1996). Pro-active safety management: Application and evaluation within a rail context. *Safety Science*, 24(2), 83–93. [https://doi.org/10.1016/0925-7535\(96\)00027-6](https://doi.org/10.1016/0925-7535(96)00027-6).
2. Hammerl, M., & Vanderhaegen, F. (2009). Human factors: in the railway system safety analysis process. *Rail Human Factors around the World. Impacts on and of People for Successful Rail Operations*, 73-84. <https://doi.org/10.1201/b12742-11>.
3. Debbech, S., Bon, P., & Collart-Dutilleul, S. (2019). A model-based system engineering approach to manage railway safety-related decisions. *International Journal of Transport Development and Integration*, 3(1), 30–43. <https://doi.org/10.2495/TDI-V3-N1-30-43>.
4. He, J., Zhang, Y., Qin, S., & Liu, W. (2022). Assessment and discussion of correlation among psychological symptoms, occupational strain, and neurotic personality for metro drivers. *Frontiers in Psychology*, 13, 823682. <https://doi.org/10.3389/fpsyg.2022.823682>.
5. Fan, C., Huang, S., Lin, S., Xu, D., Peng, Y., & Yi, S. (2022). Types, risk factors, consequences, and detection methods of train driver fatigue and distraction. *Computational intelligence and neuroscience*, 2022(1), 8328077. <https://doi.org/10.1155/2022/8328077>.
6. Song, X., Zhao, X., Li, T., & Zhang, L. (2025). Fatigue risk assessment of metro drivers based on an AHP–fuzzy comprehensive evaluation model. *Scientific Reports*, 15(1), 22486. <https://doi.org/10.1038/s41598-025-92248-6>.

7. Ouedraogo, K. A., Beugin, J., Clarhaut, J., Renaux, D., & Lisiecki, F. (2016, October). Safety integrity level allocation shared or divergent practices in the railway domain. In *Congrès de l'International Railway Safety Council (IRSC 2016)* (p. 10p). <https://hal.archives-ouvertes.fr/hal-01466807>.
8. Valdivia, L. J., Arrizabalaga, S., Añorga, J., Goya, J., Adin, I., & Mendizabal, J. (2018, April). *Integration of safety and security in railway systems*. Proceedings of the 7th Transport Research Arena (TRA 2018), Vienna, Austria. Retrieved from <https://tra2018.at>.
9. Zhang, B., Dai, B., Ge, Y., & Xu, Y. (2023). Research on risk assessment method of subway driver driving fatigue based on AHP-FCE. *Advances in Education, Humanities and Social Science Research*, 7(1), 21-27. <https://doi.org/10.56028/aehtsr.7.1.21.2023>.
10. Hassanzadeh-Rangi, N., Jalilian, H., Farshad, A. A., & Khosravi, Y. (2023). Correlation of work fatigue and mental workload in train drivers: A cross-sectional study. *Journal of Research in Health Sciences*, 23(4), e00600. <https://doi.org/10.34172/jrhrs.2023.135>.
11. Hollnagel, E. (2023). Proactive safety management: Application of the REVIEW model in the railway industry. *Safety in Extreme Environments*, 5(3-4), 201-210. <https://doi.org/10.1016/j.jrsm.2023.01227>.
12. Zhao, J., Yang, Q., & Li, M. (2024). Human factor behavioural risk analysis and safety management in railway operations. *Safety and Health at Work*, 15(2), 145-156. <https://doi.org/10.1016/j.shaw.2024.02.010>.
13. Ministry of Health of Ukraine, & State Committee of Ukraine for Supervision of Labor Protection. (1994, September 23). *List of jobs requiring professional selection: Order No. 263/121, registered with the Ministry of Justice of Ukraine on January 25, 1995, No. 18/554*. [in Ukrainian].
14. Verkhovna Rada of Ukraine. (1993). *Law of Ukraine "On Labor Protection"*. Kyiv. [in Ukrainian].
15. Samoylyk, V. O. (2023). *Research on approaches to accounting for the human factor in metro train operations (Master's thesis)*. Kyiv: State University of Infrastructure and Technologies. [in Ukrainian].
16. Wikipedia contributors. (n.d.). *Schulte tables*. Wikipedia. Retrieved from [https://uk.wikipedia.org/wiki/Таблиці\\_Шульте](https://uk.wikipedia.org/wiki/Таблиці_Шульте). [in Ukrainian].
17. Mykola Halitsky. *Schulte Tables (Gorbova-Schulte)*. <https://ispeedreader.com/en/schulte>.
18. Rudenko, V. M. (2012). *Mathematical statistics: Textbook*. Kyiv: Tsentr uchbovoi literatury. Retrieved from [https://shron1.chtyvo.org.ua/Rudenko\\_Volodymyr/Matematychna\\_statystyka.pdf](https://shron1.chtyvo.org.ua/Rudenko_Volodymyr/Matematychna_statystyka.pdf). [in Ukrainian].

**Віталій Самойлик<sup>1</sup>, Валерій Самсонкін<sup>2</sup>, Олексій Виноградов<sup>3</sup>, Олександра Соловійова<sup>4</sup>, Ірина Бізюк<sup>5</sup>**

<sup>1</sup>Магістр транспортних технологій, машиніст метро Комунального підприємства “Київський метрополітен”, 03056, Україна, м. Київ, просп. Берестейський, буд. 35. ORCID: <http://orcid.org/0009-0005-6626-1275>.

<sup>2</sup>Доктор наук, професор кафедри технологій транспорту та управління процесами перевезень Національного Транспортного Університету, 03115, Україна, м. Київ, вул. Котельникова, буд. 29/18. ORCID: <http://orcid.org/0000-0002-1521-2263>.

<sup>3</sup>Аспірант кафедри технологій транспорту та управління процесами перевезень Національного Транспортного Університету, 03115, Україна, м. Київ, вул. Котельникова, буд. 29/18. ORCID: <https://orcid.org/0009-0001-9096-9020>.

<sup>4</sup>Доктор філософії, старший викладач кафедри технологій транспорту та управління процесами перевезень Національного Транспортного Університету, 03115, Україна, м. Київ, вул. Котельникова, буд. 29/18. ORCID: <http://orcid.org/0000-0002-7933-3929>.

<sup>5</sup>Старший викладач кафедри обчислювальної техніки та систем управління Українського Державного Університету Залізничного Транспорту, 61050, Україна, м. Харків, майдан Фейєрбаха, 7. ORCID: <http://orcid.org/0000-0002-6458-5701>.

## **Людський фактор в експлуатації метро: визначення стану водія під час передрейсових процедур**

*Анотація.* У статті досліджено вплив людського чинника на надійність та безпеку роботи

метрополітену, зосереджено увагу на методах оцінювання психофізіологічного стану машиністів перед початком зміни. Проаналізовано діючу систему контролю людського чинника в Київському метрополітені та підкреслено необхідність упровадження об'єктивних діагностичних засобів у щоденну практику безпеки руху. Експериментальні дослідження із застосуванням таблиць Шульте–Горбова дали змогу оцінити стійкість уваги, швидкість сприйняття та когнітивну реакцію машиніста. Протягом місяця самотестування до і після зміни виявлено статистично значущі відмінності у результатах залежно від функціонального стану працівника - нормального, сонливого чи втомленого. Аналіз показав, що втома та зниження бадьорості спричиняють уповільнення реакції, погіршення концентрації та уваги, що негативно впливає на безпеку керування. Отримані результати підтверджують ефективність тесту Шульте як дієвого інструменту для моніторингу психофізіологічної готовності машиністів і попередження помилок, пов'язаних із людським чинником.

**Ключові слова:** залізничний транспорт, людина-оператор, автоматизоване керування, ергатична система, психофізіологічний стан водія, тестування.

*Дата першого надходження статті до видання 02.11.2025*

*Дата прийняття до друку статті 24.11.2025*

## CONTENT

<i>Liashenko V., Yatsko S.</i> Study of influence of imprecision of primary information on energy consumption of rolling stock.	7
<i>Babicheva O., Shavkun V., Yesaulov S.</i> Comprehensive analysis of the sensitivity and criticality of power equipment elements of urban electric transport to operational factors based on structural-functional ranking.	21
<i>Lytvyn V., Klymenko I.</i> Study of the impact of route parameters on fuel consumption by buses in urban conditions	41
<i>Sorochynska O., Melnichenko O., Kulbovskiy I., Tkachenko V.</i> System model for the formation of organizational and technical processes for the prevention of emergency situations in transport complex projects.	52
<i>Riabov Ie., Overianova L., Ivanov K., Bilokon I., Zhukov A.</i> Development of a Hybrid Traction System for a Suburban Multiple Electric Train with Dual Power Supply.	64
<i>Khaustov O., Liubarskyi B.</i> Optimization of energy storage parameters of electric buses charged at terminal stops.	76
<i>Petrychenko O., Burmaka I., Vynohradova A., Stoliaryk T.</i> Structural crisis in contemporary higher education: a systemic approach to institutional resilience and transformation.	94
<i>Orda O., Holubnichii Ye.</i> Planning of Bicycle Infrastructure for Urban Sustainable Mobility: Kharkiv Case Study	114
<i>Zalata A.</i> Methodology for Training a Neuro-Fuzzy Control System for a Diesel-Generator Unit Under Variable Operating Conditions.	128
<i>Karnatov S.</i> Analysis of PSNR, SSIM, LPIPS metrics in the context of human perception of visual similarity.	140
<i>Nesterenko O.</i> Methodological Aspects and Models for Assessing the Effectiveness of Artificial Intelligence in Project Management.	151
<i>Danak O.</i> Conceptual principles of building intelligent computer networks for monitoring energy consumption of railways.	168
<i>Shostak Ya., Reshetnikov Yu.</i> Improvement of the technology of treatment motor windings in order to improve rotor imbalance parameters.	179
<i>Samoilyk Vi., Samsonkin V. Vynohradov O., Soloviova O., Biziuk I.</i> The Human Factor in Metro Operations: Determining the Driver's Condition During Pre-Departure Procedures	190

*Наукове видання*  
*Scientific edition*

**Транспортні системи і технології**  
**Transport Systems and Technologies**

**Випуск 46**  
**Issue 46**

Головний редактор О. М. Горобченко

Відповідальний за випуск С. О. Гулак

Підписано до видання 05.12.2025.

Ідентифікатор медіа - R30-05246

03049, м. Київ-49, вул. І. Огієнка, 19.  
<https://tst.duit.in.ua/>